

R53 VERTEX

- 1 Profiles and accessories
- 2 Profiles and accessories
- 3 Glazing screws
- 4 Mounting of skylight roof T-joint
- 5 Mounting of skylight roof T-joint, 0-frame
- 6 Alternative mounting of skylight roof T-joint glazing lists
- 7 Ridge mounting with two profiles
- 8 Ridge mounting with profile R53-956-290 (90°)
- 9 Mounting of the top of quadrilateral pyramidal roof
- 10 Mounting of the top of polygonal pyramidal roof
- 11 Angle joints assembly of hip roof
- 12 Skylight roof joining with R54 structure
- 13 Joining with building frame
- 14 Adjustable eaves profiles
- 15 Barrel vault joining with frame structure
- 16 Barrel vault joints manufacturing
- 17 Joints manufacturing
- 18 Opening skylight and joining with structure
- 19 Opening skylight, Vertical section 1:2
- 20 Opening skylight, Horizontal section 1:2
- 21 Opening skylight, Angle joints 1:2
- 22 Opening skylight, Hinge fastening and machining 1:2
- 23 Opening skylight, joining with separate frame and joining with triplex structure
- 24 Opening equipments of shutter
- 25 Expansion joint
- 26 Glazing
- 27 Glazing
- 28 Glazing. Glass selection. Glazing instructions
- 29 Use of cover plates

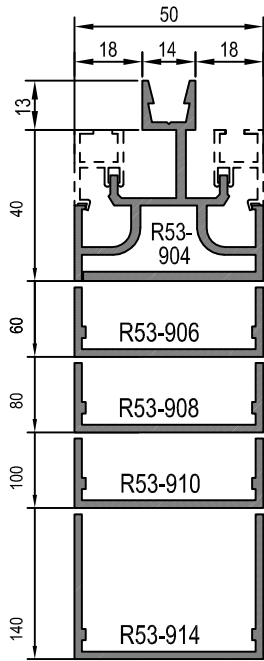

Vertical frame

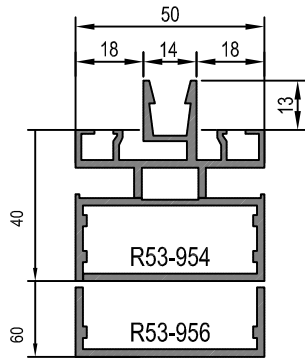

Horizontal frame

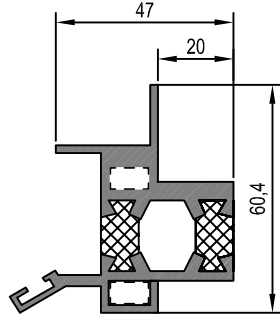

Skylight window frame R53-931

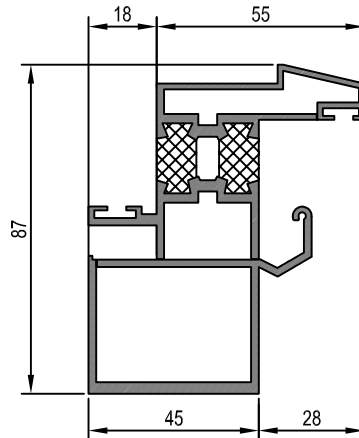

Skylight window frame R53-935

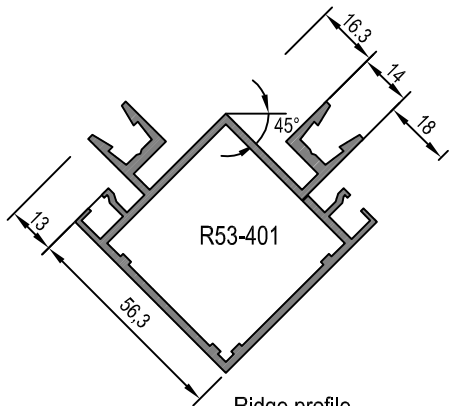

Ridge profile R53-956-90

Adjustable eaves profile

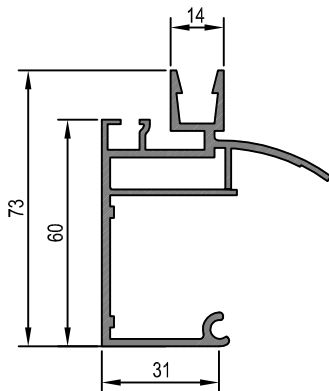

Adjustable eaves profile R53-956-S2

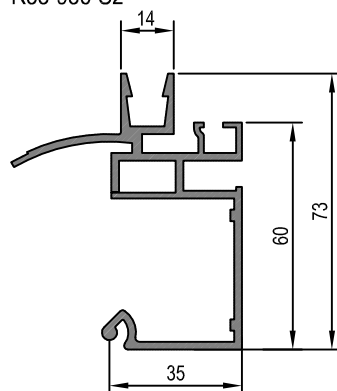

Inside glazing beads

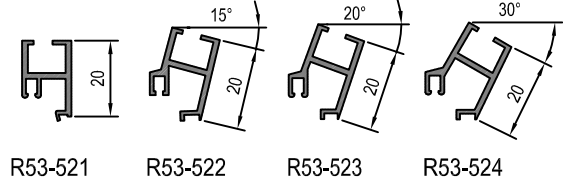

R53-521 R53-522 R53-523 R53-524

Glazing beads

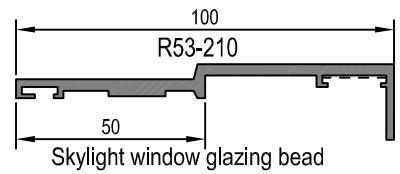
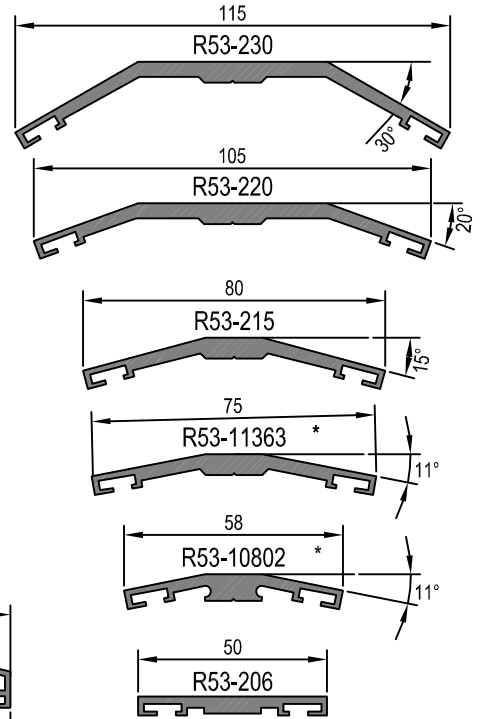

Skylight window glazing bead

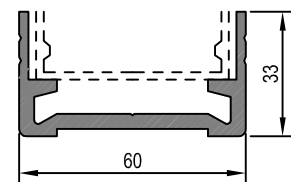

Anchoring profile R53-530

* Ex factory

01.07.2013

Frames on separate frames

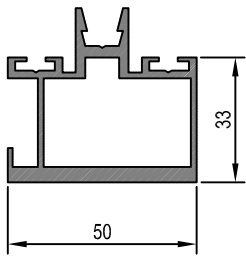

Horizontal frame
R53-950-Fe

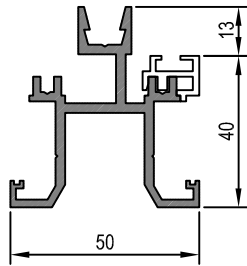

Vertical frame
R53-900-Fe

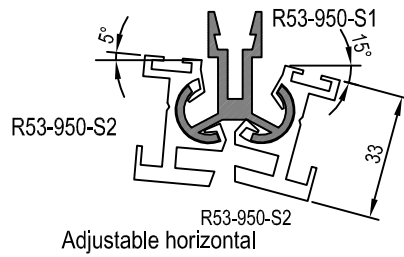

Adjustable horizontal



Inside glazing bead
R53-526

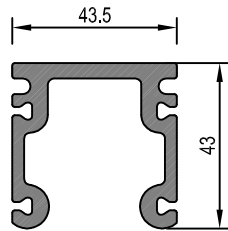

T-joint profile
R53-401

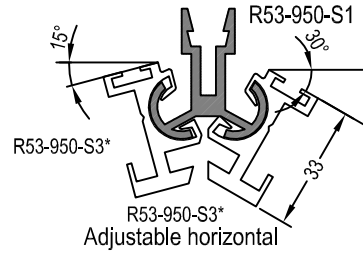

Adjustable horizontal

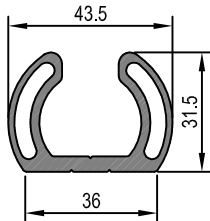

optional angle T-joint profile
R53-428

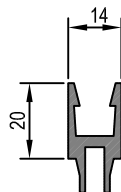

Auxiliary profile 2k->3k
R53-520



Heat-insulating profile
R53-604
length 6,6
plastic

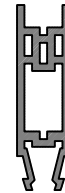

Heat-insulating profiles
R53-605
length 6,6
plastic

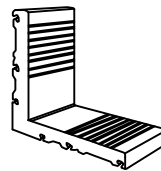

Joint profile
R65-428

Butyl tapes

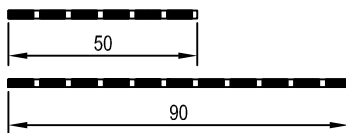

Gusset plate
R65-801

Angle clip
R65-802

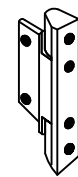

Skylight window hinge
R53-712



Sealing



Sealing



Sealing



Sealing



Sealing



Angle joint
R65-821

* Ex factory

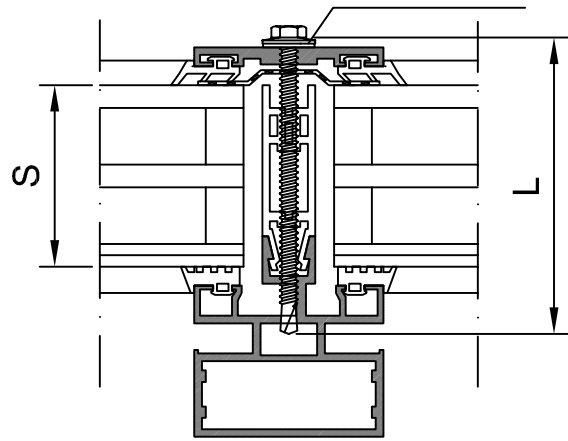
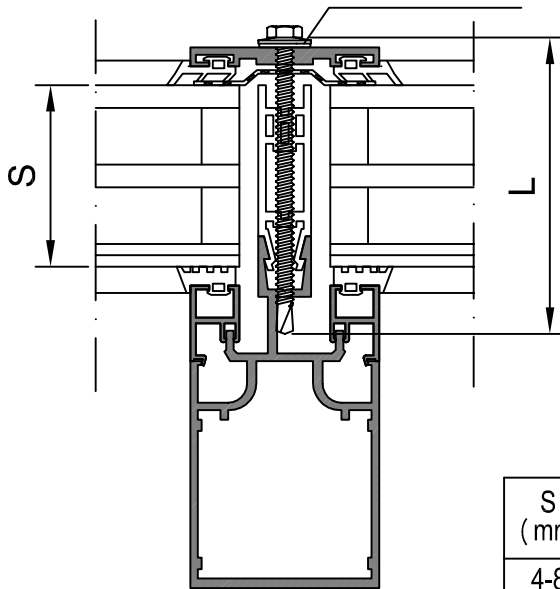

Corners

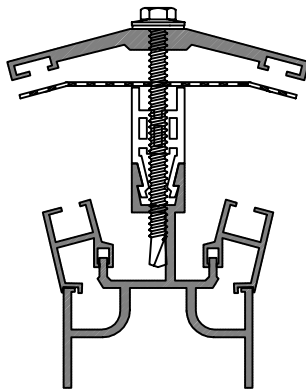

S (mm)	Outern gasket	Item number	L (mm)	Thermobreak
4-8	619 or 611	R53-4838P	38	No thermobreak
9-10	611	R53-4838P	38	No thermobreak
9-10	619	R53-4845P	45	No thermobreak
11-15	619 or 611	R53-4845P	45	No thermobreak
16-17	611	R53-4845P	45	No thermobreak
14-15	619	R53-4850P	50	No thermobreak
16-20	619 or 611	R53-4850P	50	No thermobreak
21-22	611	R53-4850P	50	No thermobreak
24	619	R53-4860P	60	No thermobreak
25	619	R53-4860P	60	R53-604
26-30	619 or 611	R53-4860P	60	R53-604
31-32	611	R53-4860P	60	R53-604
34-35	619	R54-4870P	70	R53-604
36-40	619 or 611	R54-4870P	70	R53-604
41-42	611	R54-4870P	70	R53-604
44	619	R54-4880P	80	R53-604
45	619	R54-4880P	80	R53-605
46-50	619 or 611	R54-4880P	80	R53-605
51-52	611	R54-4880P	80	R53-605
washer		pr14	ø 14	

Fixing of R53-520 profile

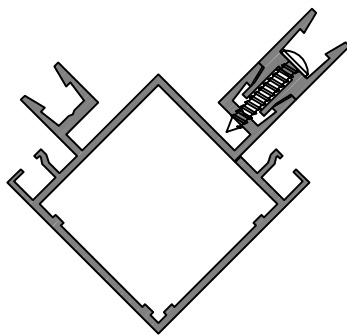

Countersunk head tapping screw 4,2x25
C/C 200 DIN 7981 A2

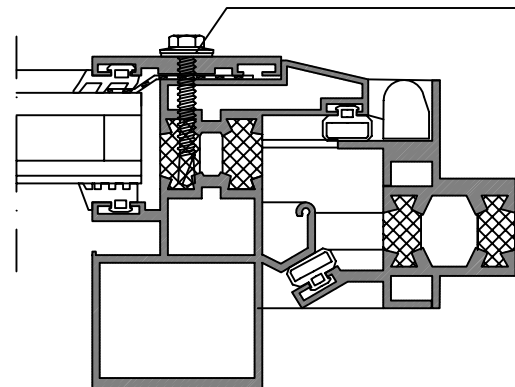

Horizontal profile dimension = light opening measurement + 32

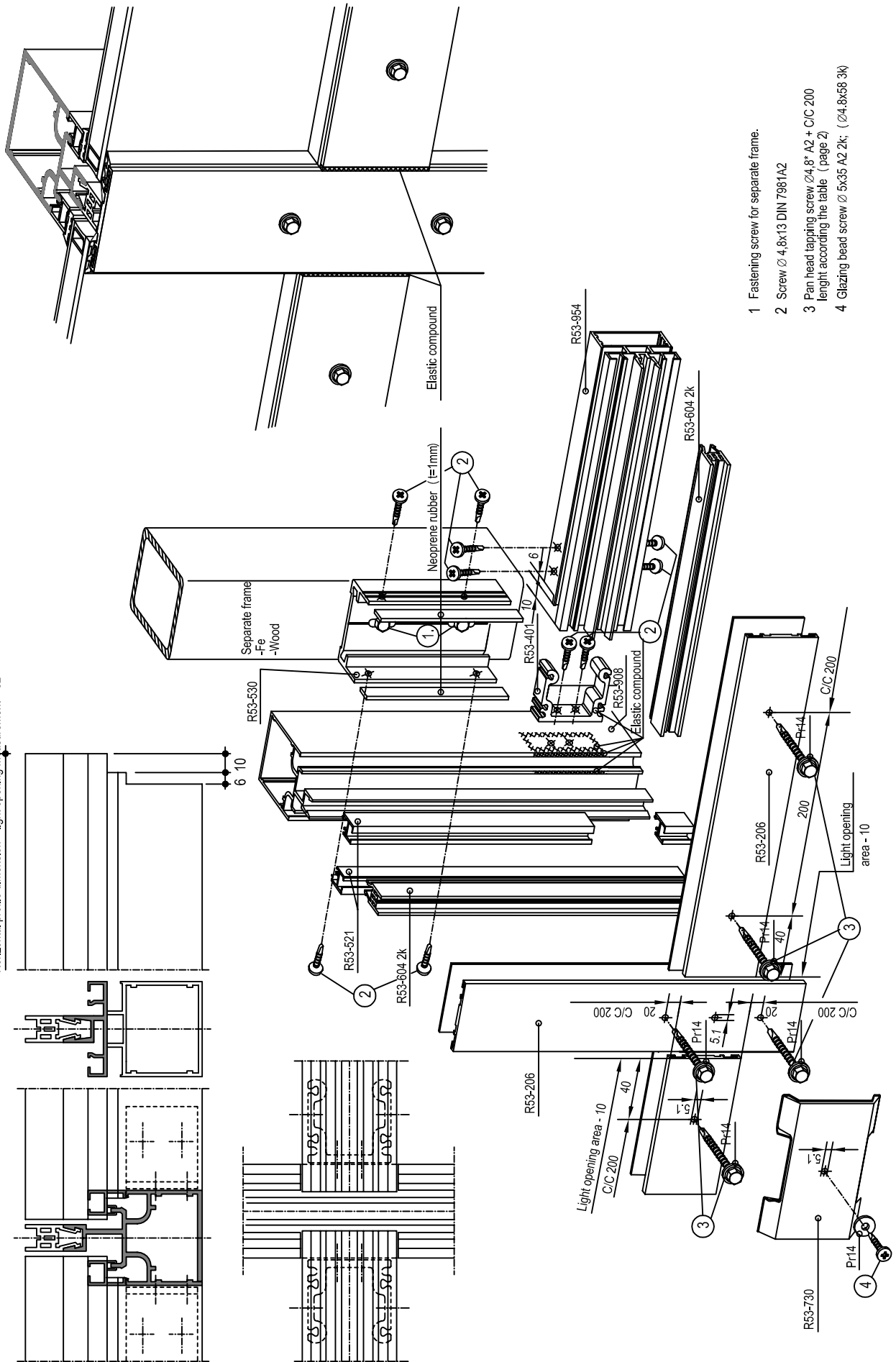

- 1 Fastening screw for separate frame.
- 2 Screw \varnothing 4,8x13 DIN 7981A2
- 3 Pan head tapping screw \varnothing 4,8* A2 + C/C 200 height according the table (page 2)
- 4 Glazing bead screw \varnothing 5x35 A2 2k; (\varnothing 4,8x56 3k)

01.07.2013

Horizontal profile dimension = light opening measurement + 32

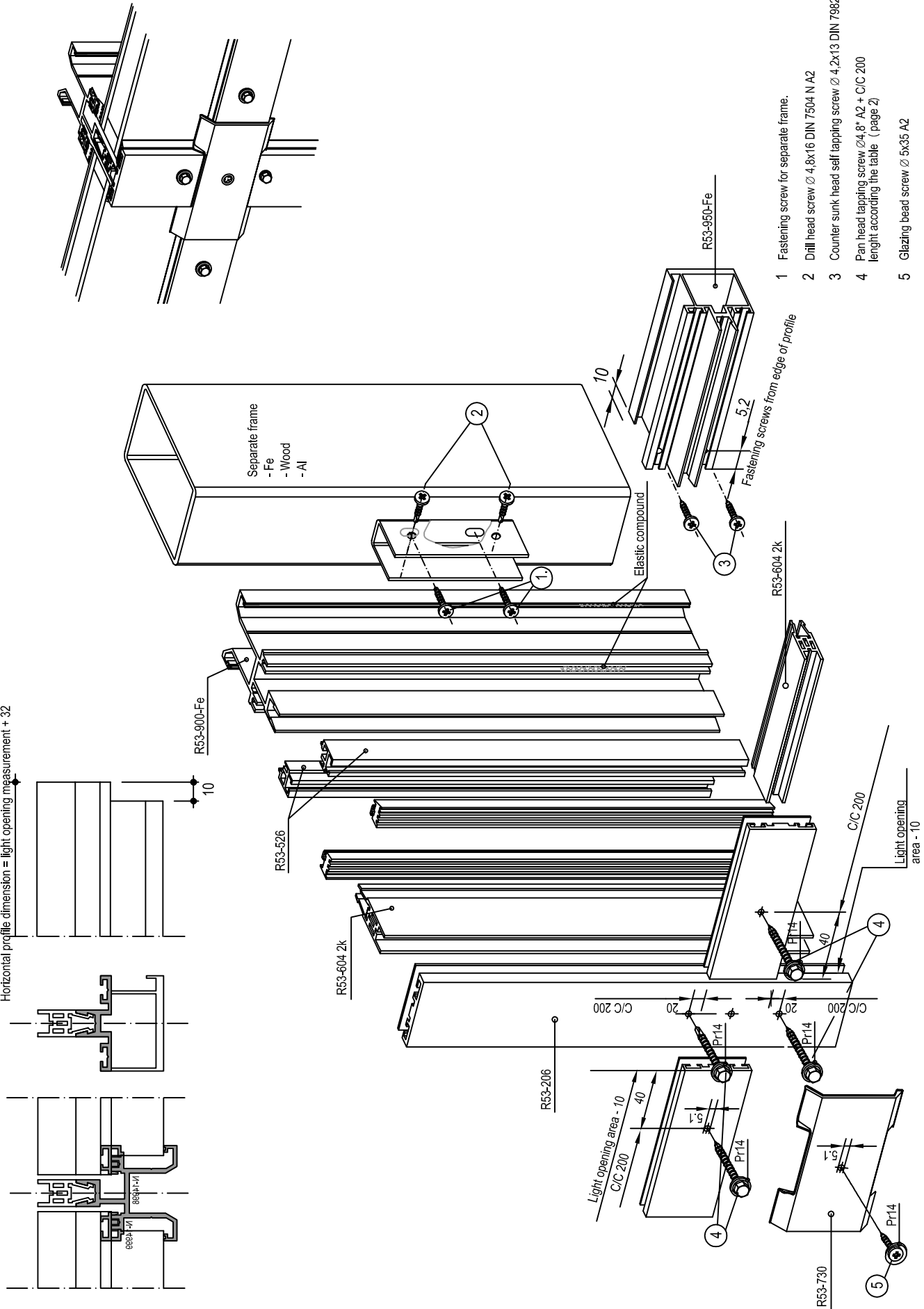

- 1 Fastening screw for separate frame.
- 2 Drill head screw \varnothing 4,8x16 DIN 7504 N A2
- 3 Counter sunk head self tapping screw \varnothing 4,2x13 DIN 7982 C A2
- 4 Pan head tapping screw \varnothing 4,8* A2 + C/C 200 length according the table (page 2)
- 5 Glazing bead screw \varnothing 5x35 A2

01.07.2013

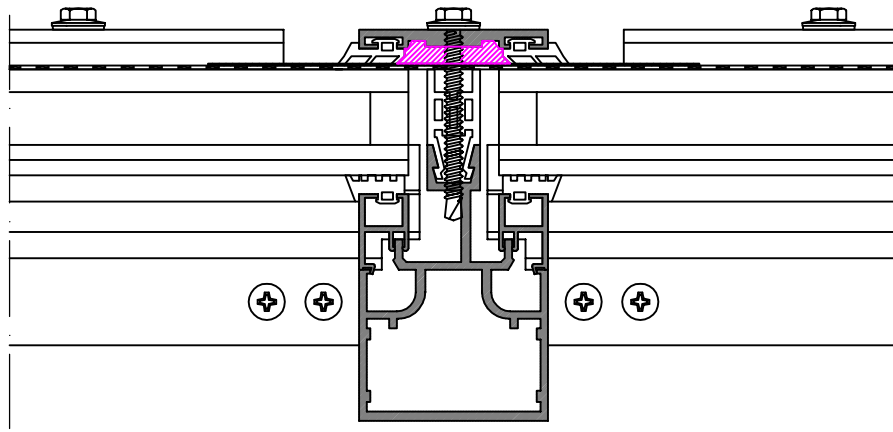

A-A

e.g. Stainless 130x50x0,5

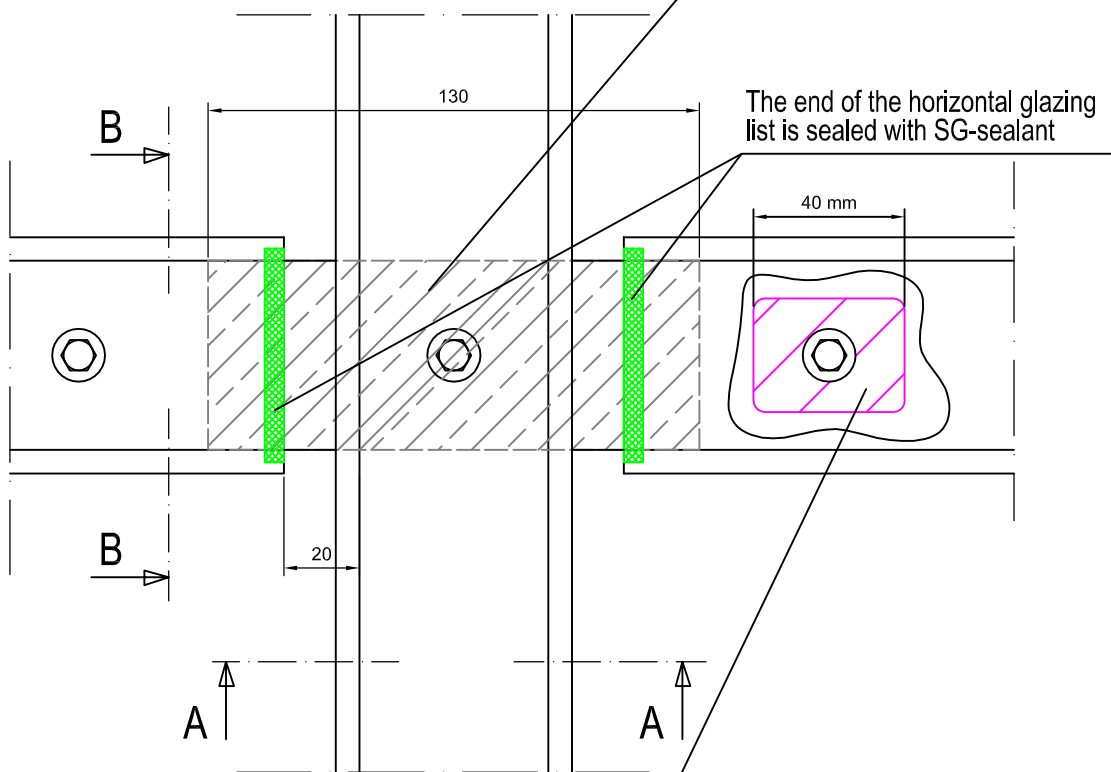

Weatherproof mass before screwing

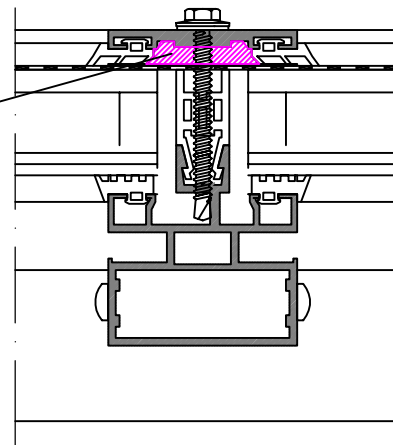

B-B

01.07.2013

R53
VERTEX

6

NOKIAN
PROFILES

Alternative T-joint for glazing lists

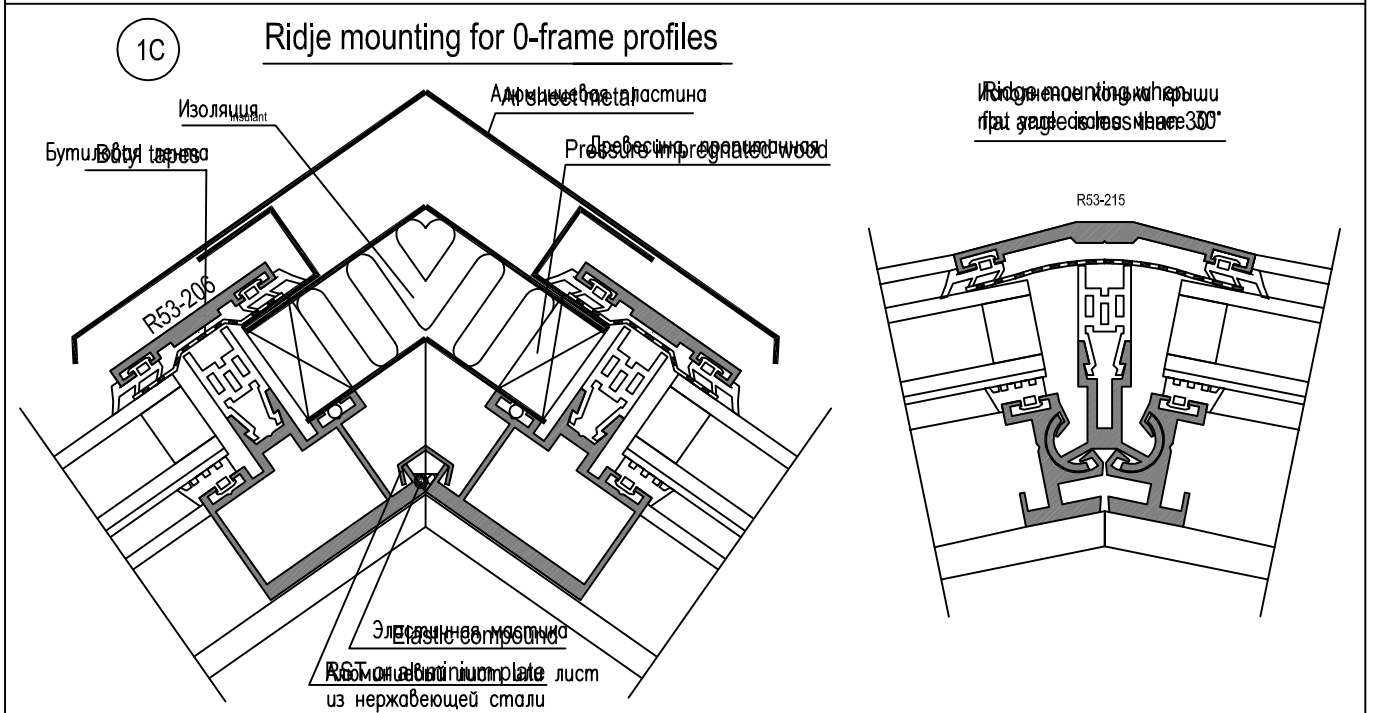
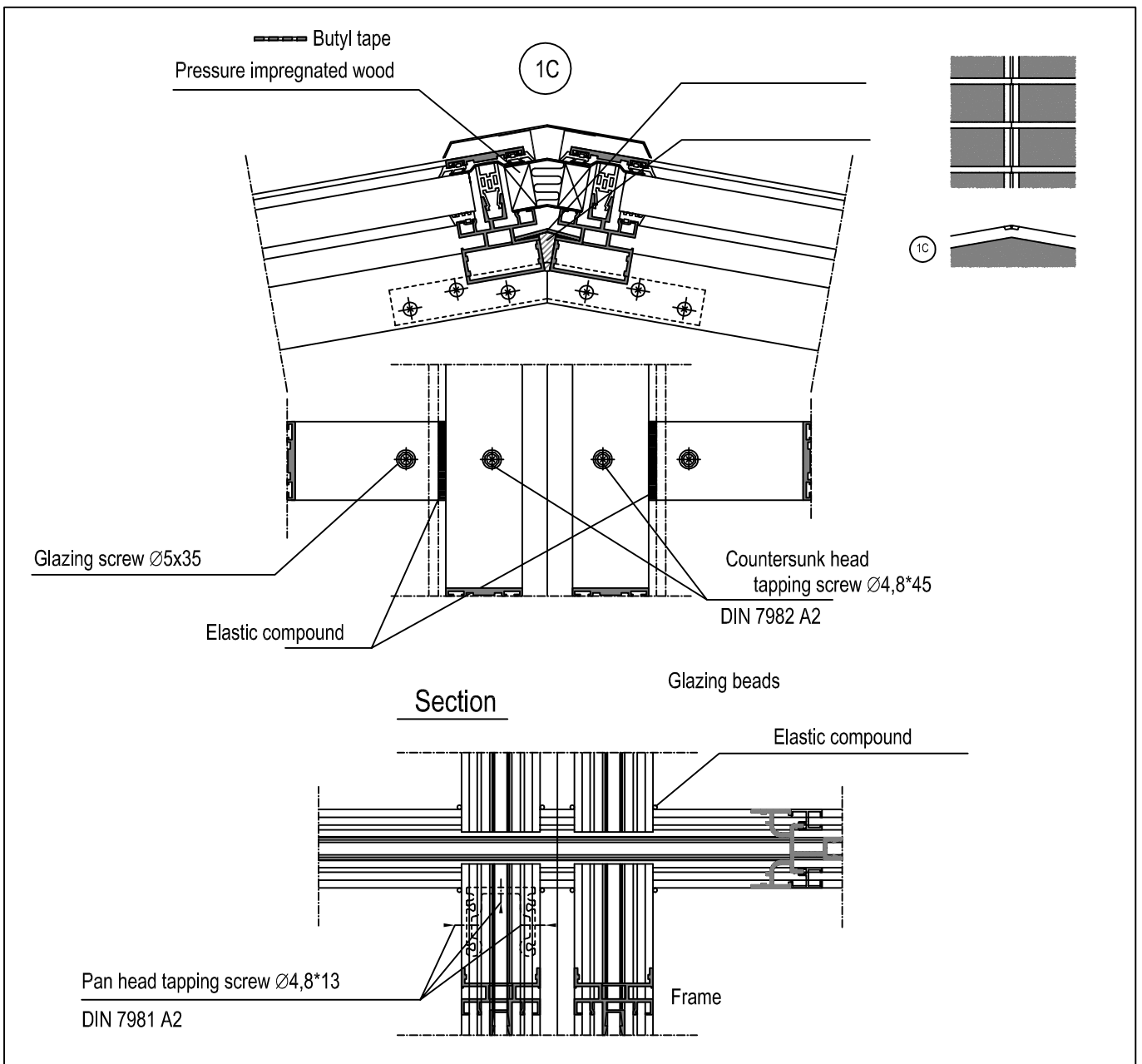

01.07.2013

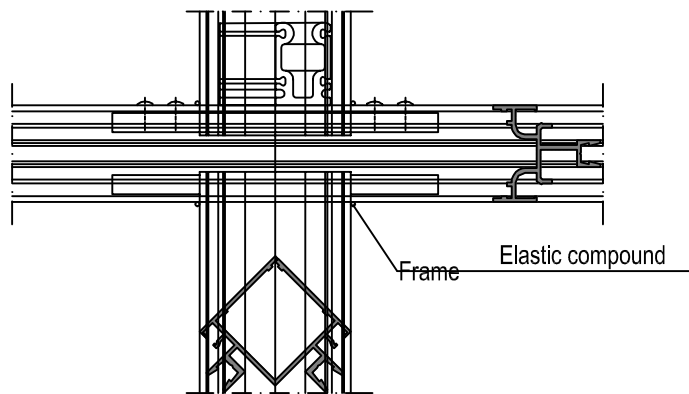
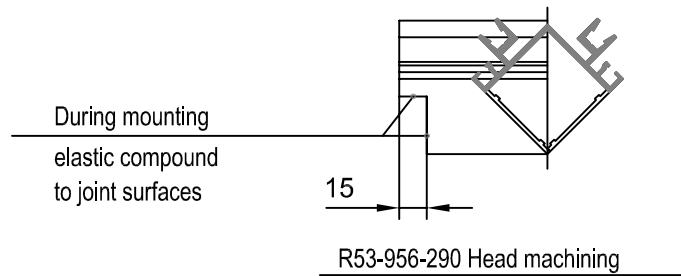
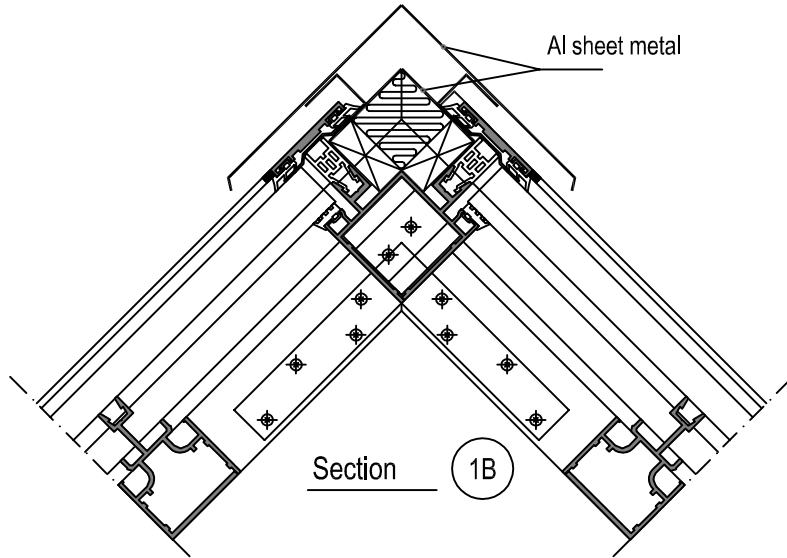
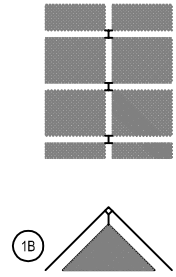
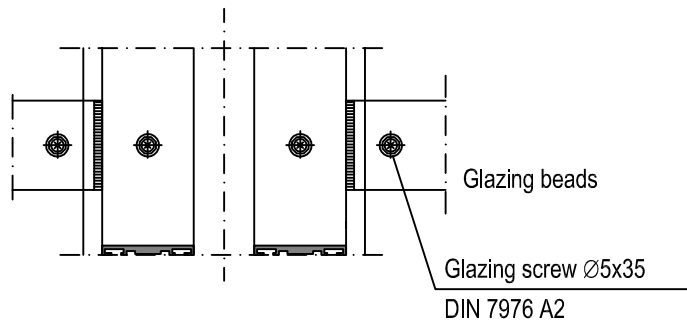

01.07.2013

R53
VERTEX

8

NOKIAN
PROFILES

Ridge mounting with profile R53-956-290 (90°)

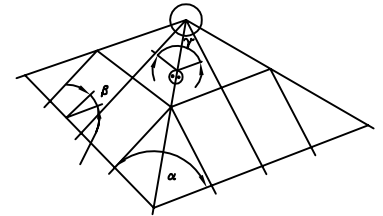
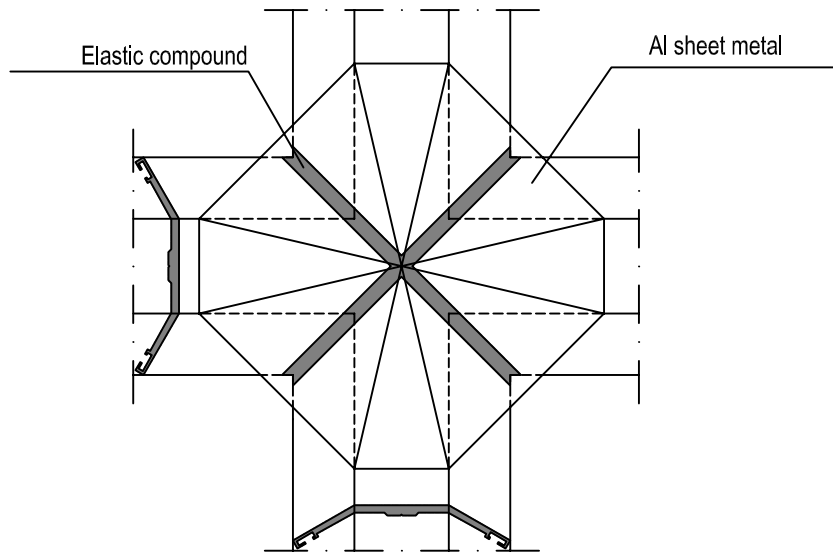

Cross-cutting of outside cover profiles / capping

Note! This structure type functions only with certain angles.

Selection of external and internal glazing beads

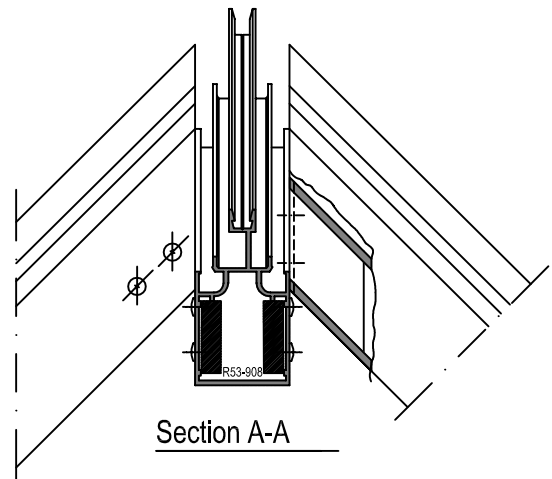

Outside:		Roof fall		β
layout	α	30°	45°	60°
quadrangle	90°	R53-220	R53-230	
Inside:				
quadrangle	90°	R53-523	R53-524	

Frame assembly

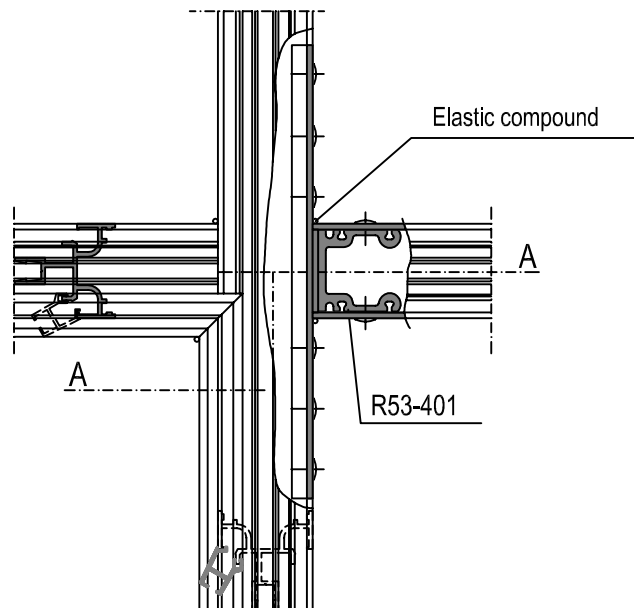

Top sealing/capping

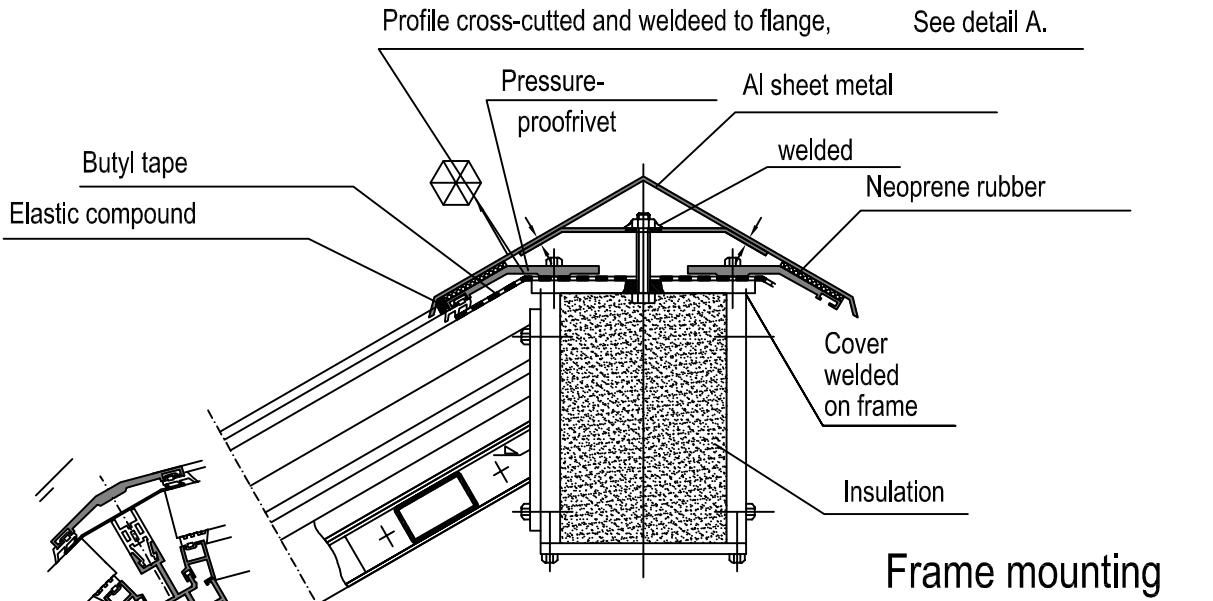

DET A

Flange manufacturing/fastening
Sealing of glazing bead heads

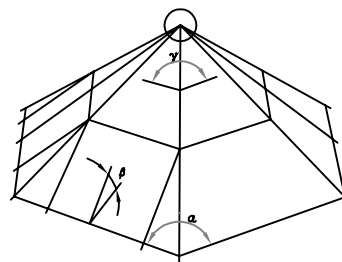
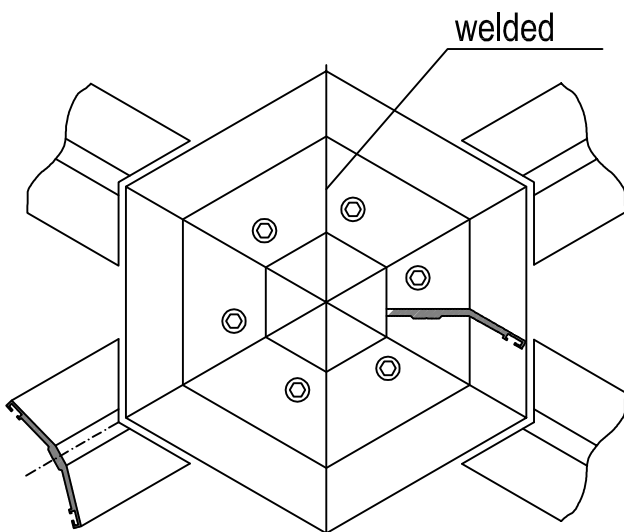
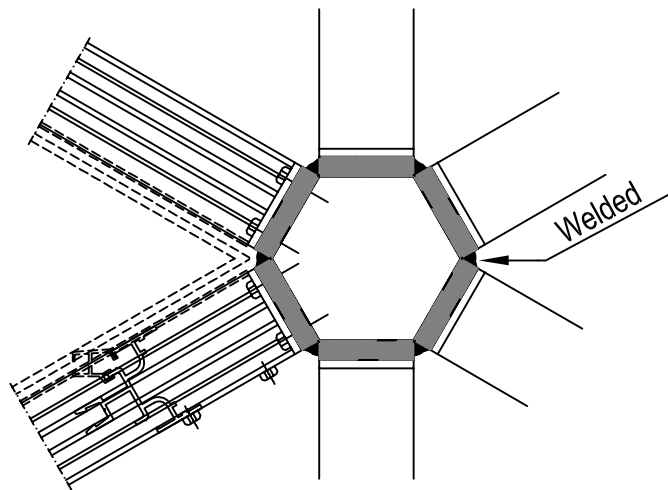

Selection of external and internal glazing beads

Outside:				
		Roof fall		β
layout	α	30°	45°	60°
Hexagon	120°	R53-215	R53-220	
Octagon	135°	R53-11363	R53-215	R53-220
Dodecagon	150°		R53-11363	R53-215
Inside:				
Hexagon	120°	R53-522	R53-523	
Octagon	135°		R53-522	R53-523
Dodecagon	120°			R52-522

01.07.2013



Mounting of the top of polygonal pyramidal roof

Note! Profile sizes of horizontal and vertical frames joining with angle profile of hip or pyramid must be smaller than frame profile so that joints align correctly.

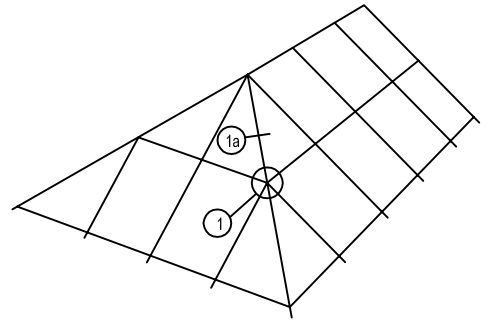
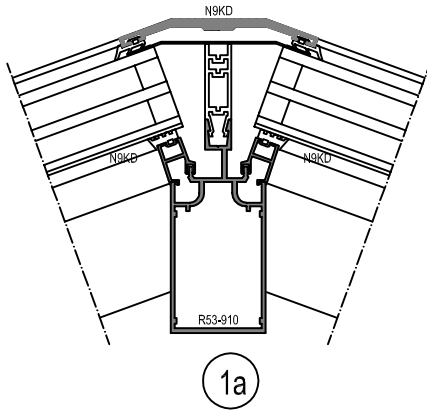

1 Angle assembly of hip or pyramid with one profile
Horizontal/vertical profile joints with angle profile

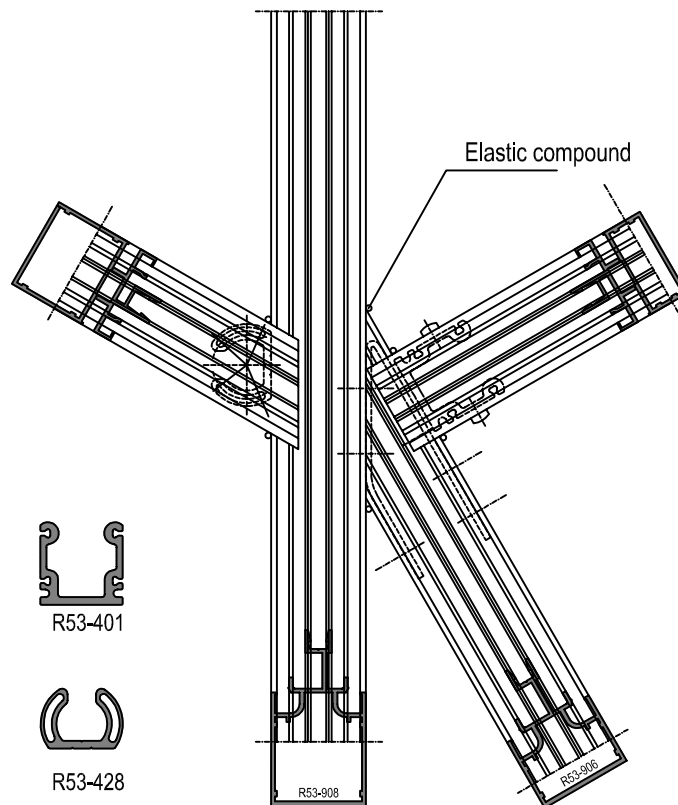

01.07.2013

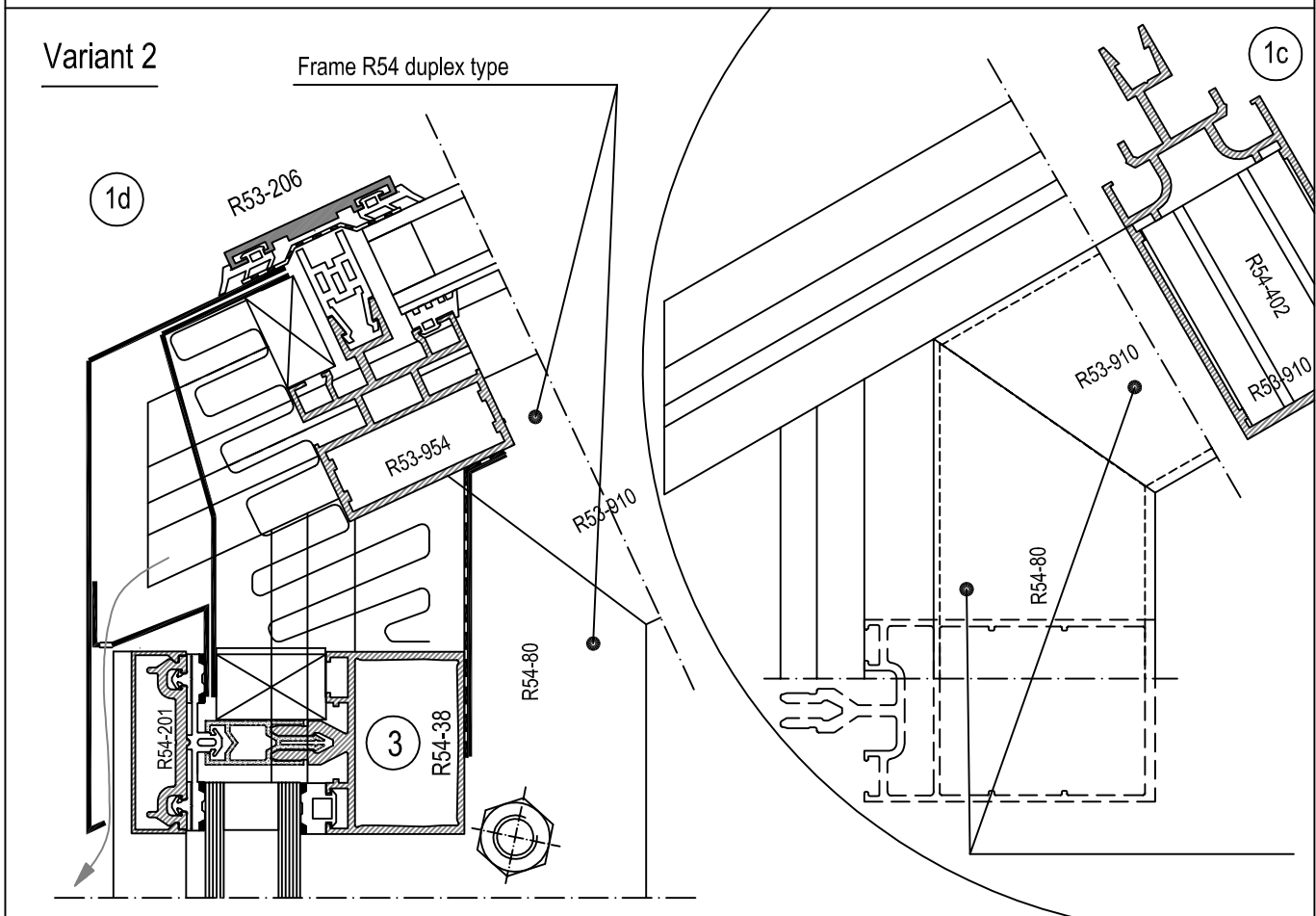
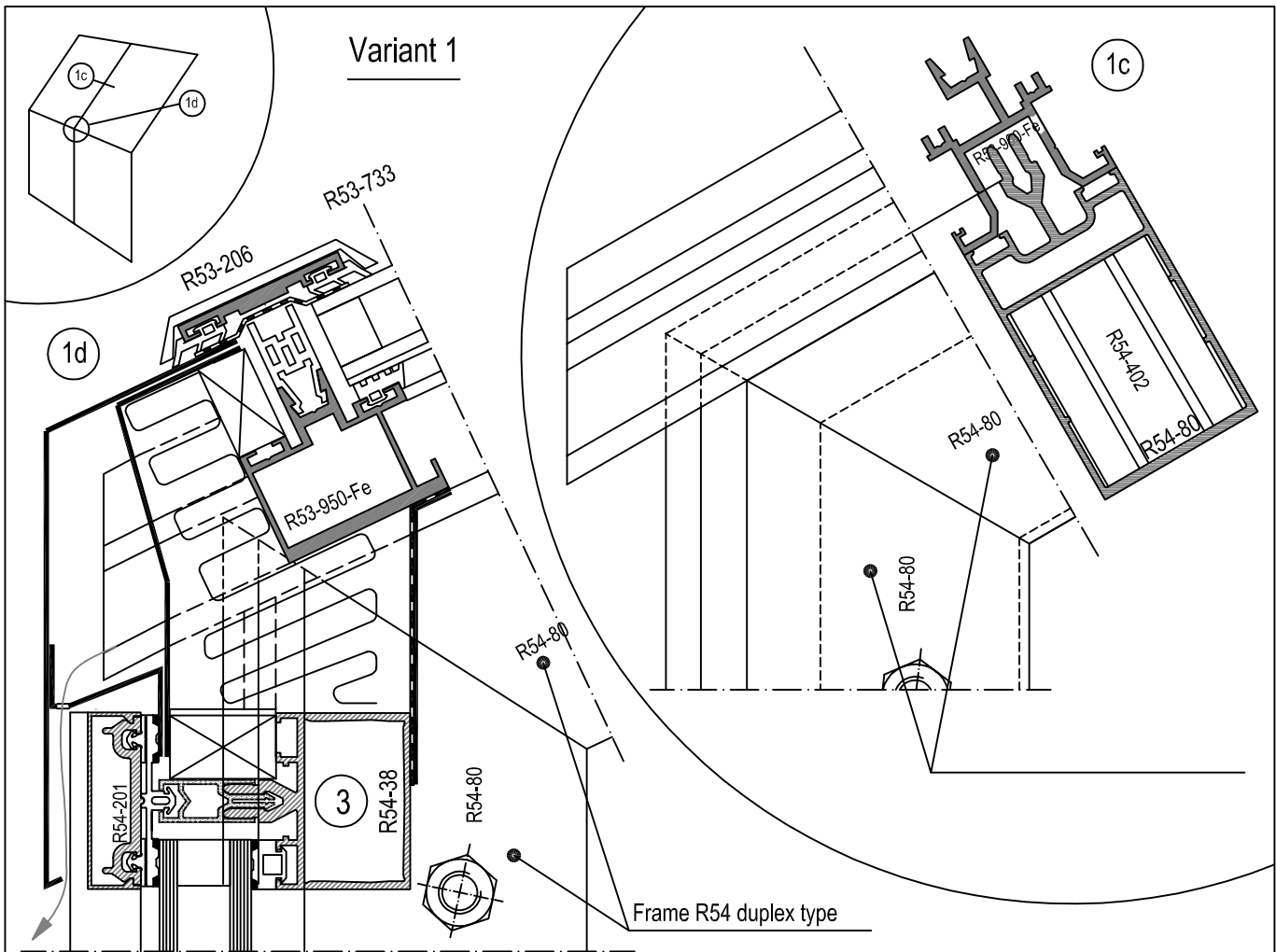

01.07.2013

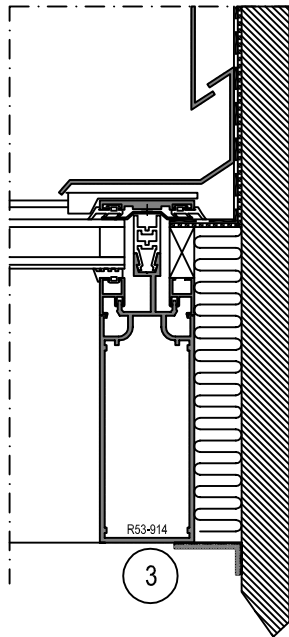
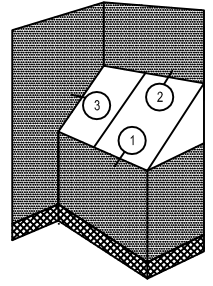

SPECIAL ATTENTION must be paid to joints between Building frame and skylight roof.

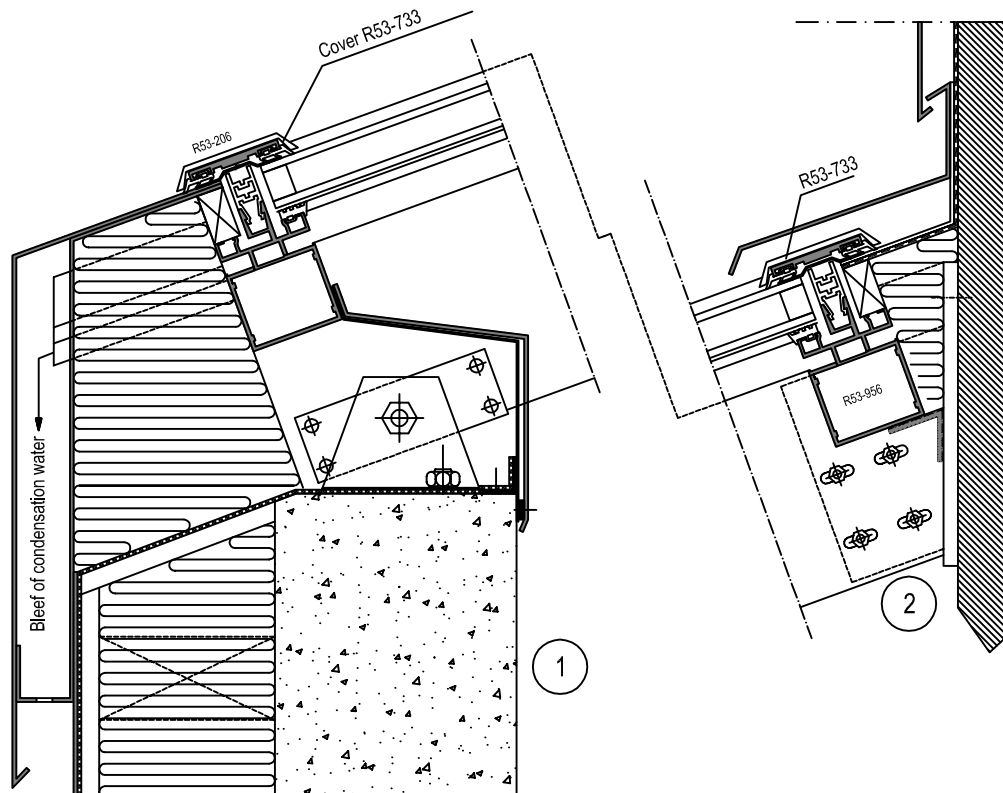

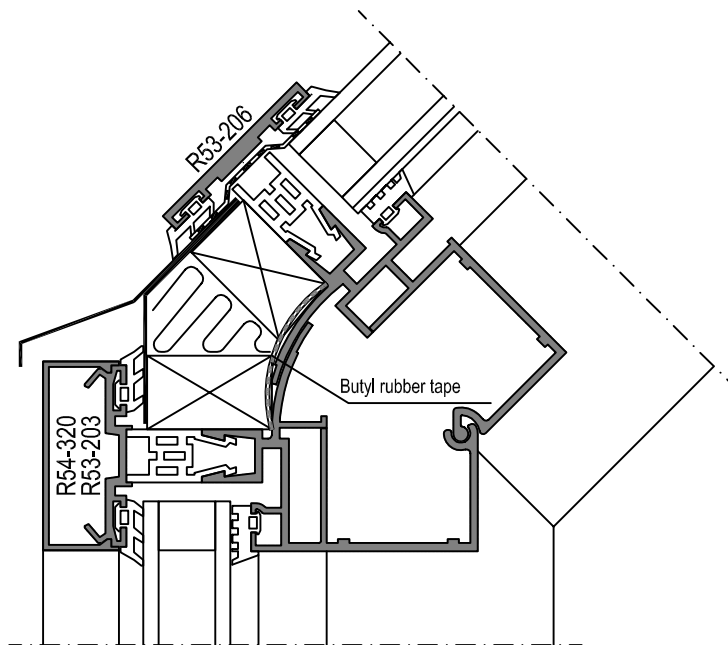

Fastening on wood frame

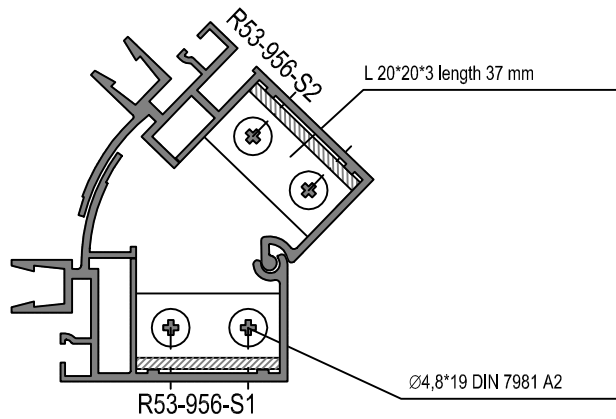

Profile head machining

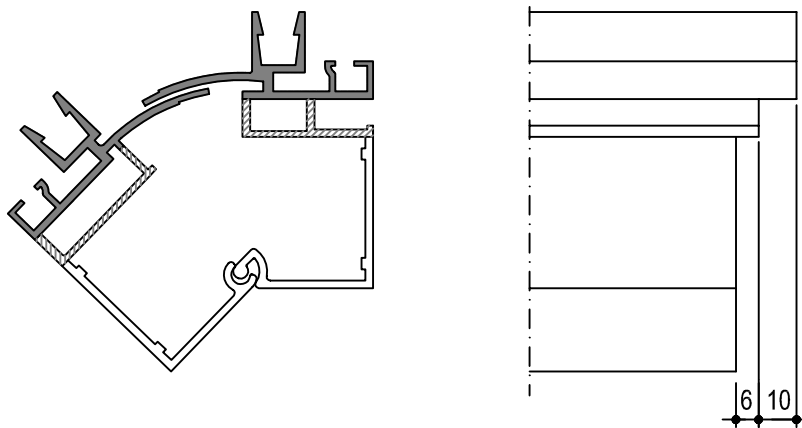

01.07.2013

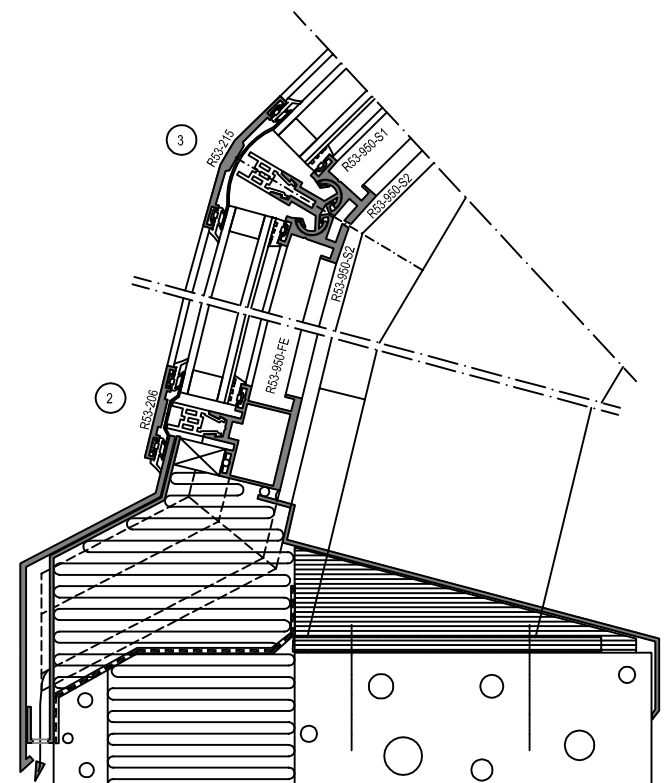
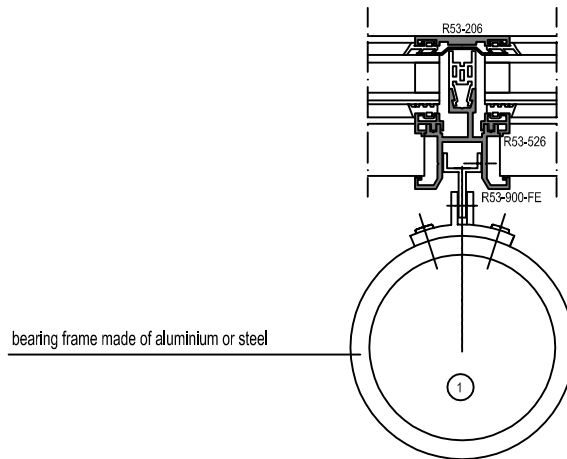
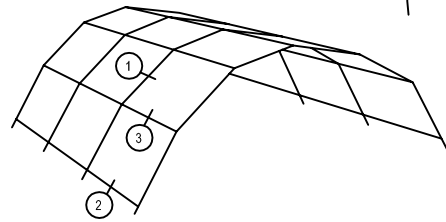
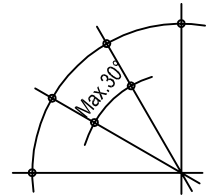

01.07.2013

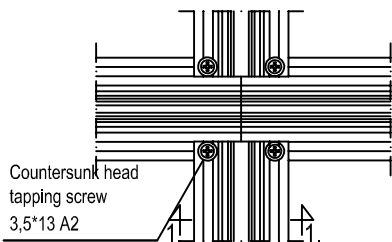
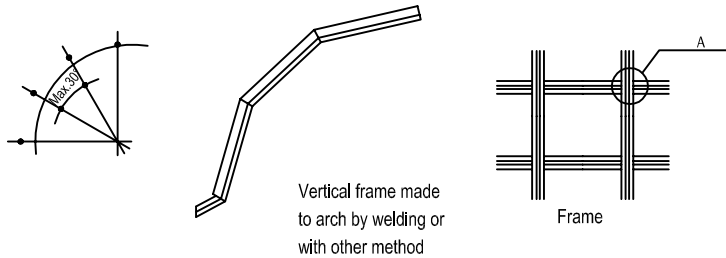

Assembly of barrel vault's A joint

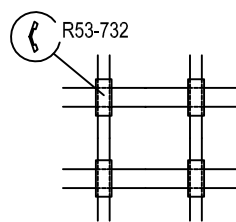
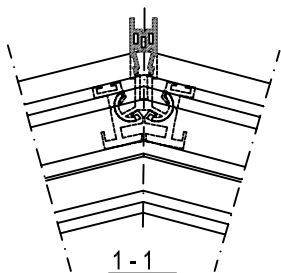

Machining of horizontal profile head

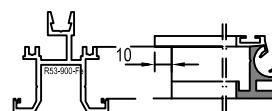

Lined part will be machined.

Elastic compound during assembly (not to leaking or condensing water drip grooves)
Fitting order see page R53V-17

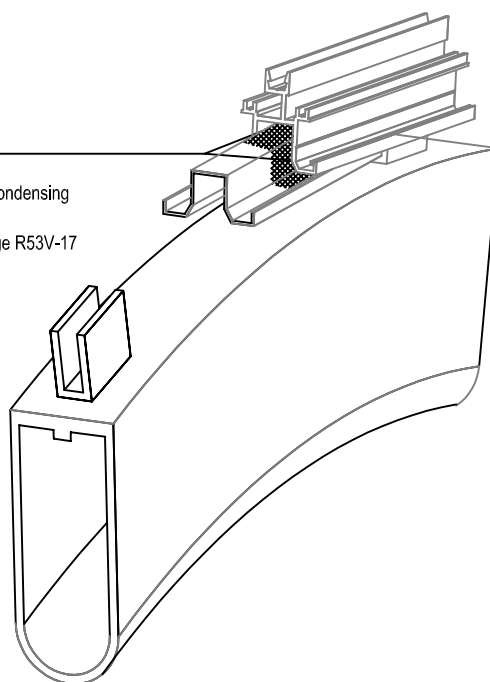

Extension of vertical profile

when using joint profile
the main chamber of upper profile
must seal from it's top

the final sealing is made
from hole drilled to upper
profile

through drilling
screws M10x60
material: stainless steel
8 pcs / joint
smaller profiles
4 pcs / joint

space must leave
for possible
fixing piece

lengthening piece length for ex. 500 mm
Al or galvanized Fe
glue Araldit Standard

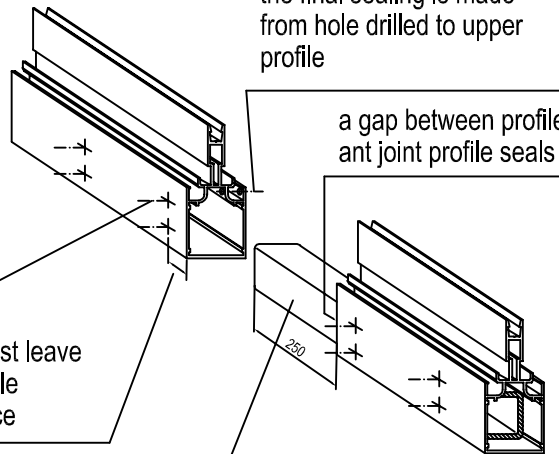

Making joint with sealing profile

Sealing profile
R53-403



Mounting sequence
-screwing of lengthening piece
-head sealing
-fixing next profile
-screwing of lengthening piece

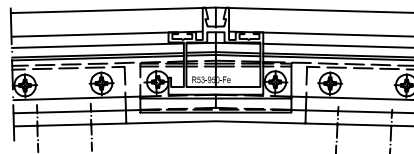
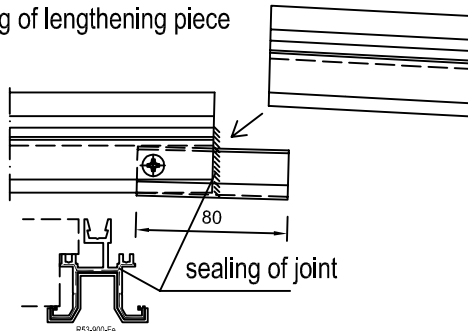

01.07.2013

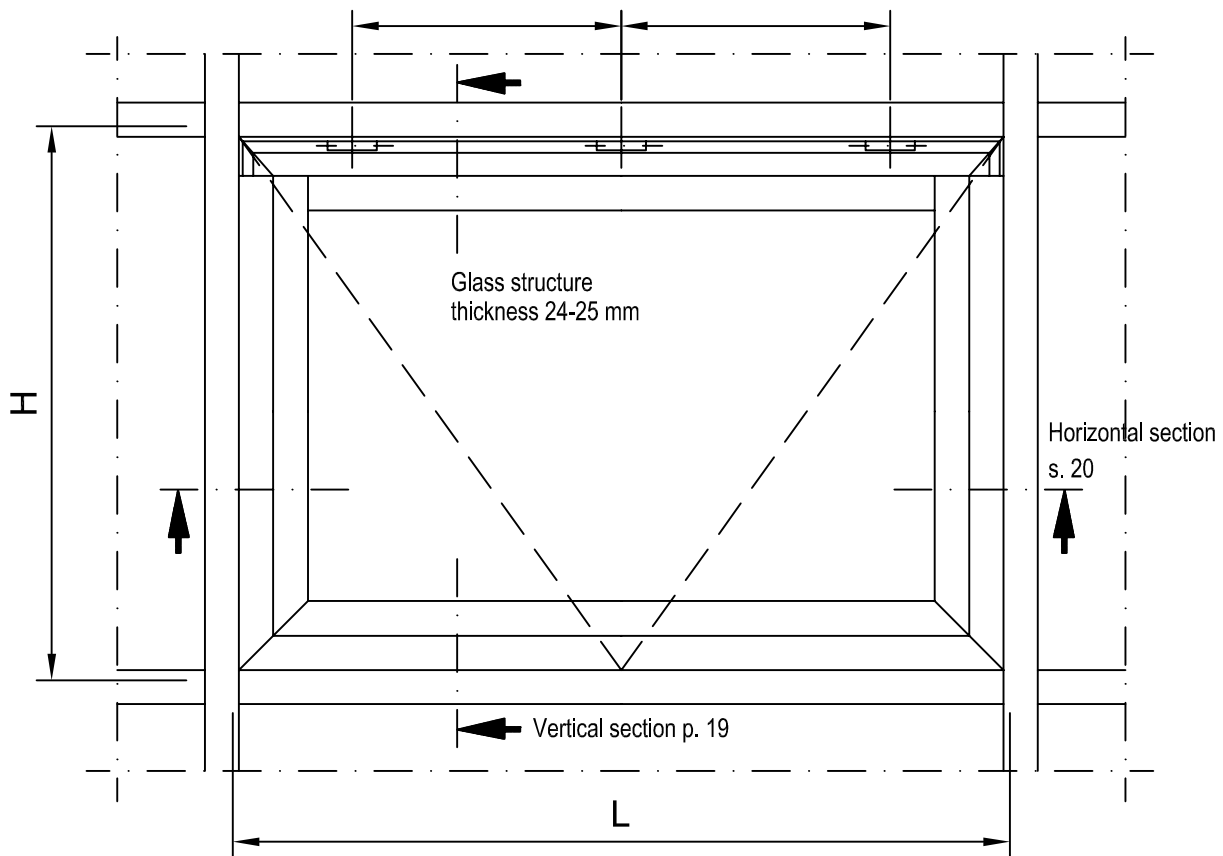

Skylight max/min sizes (H/L)

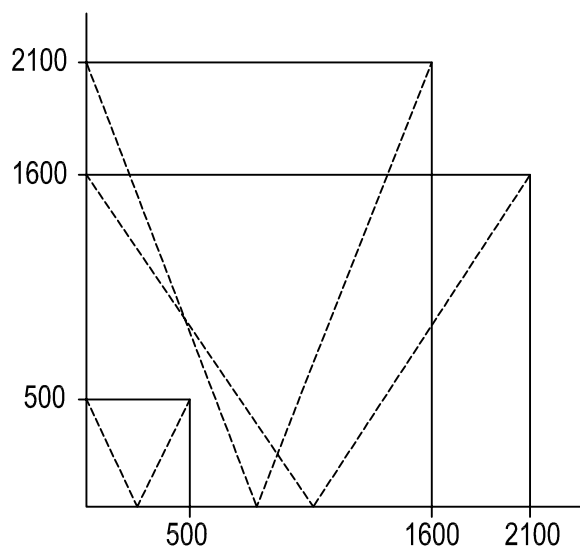

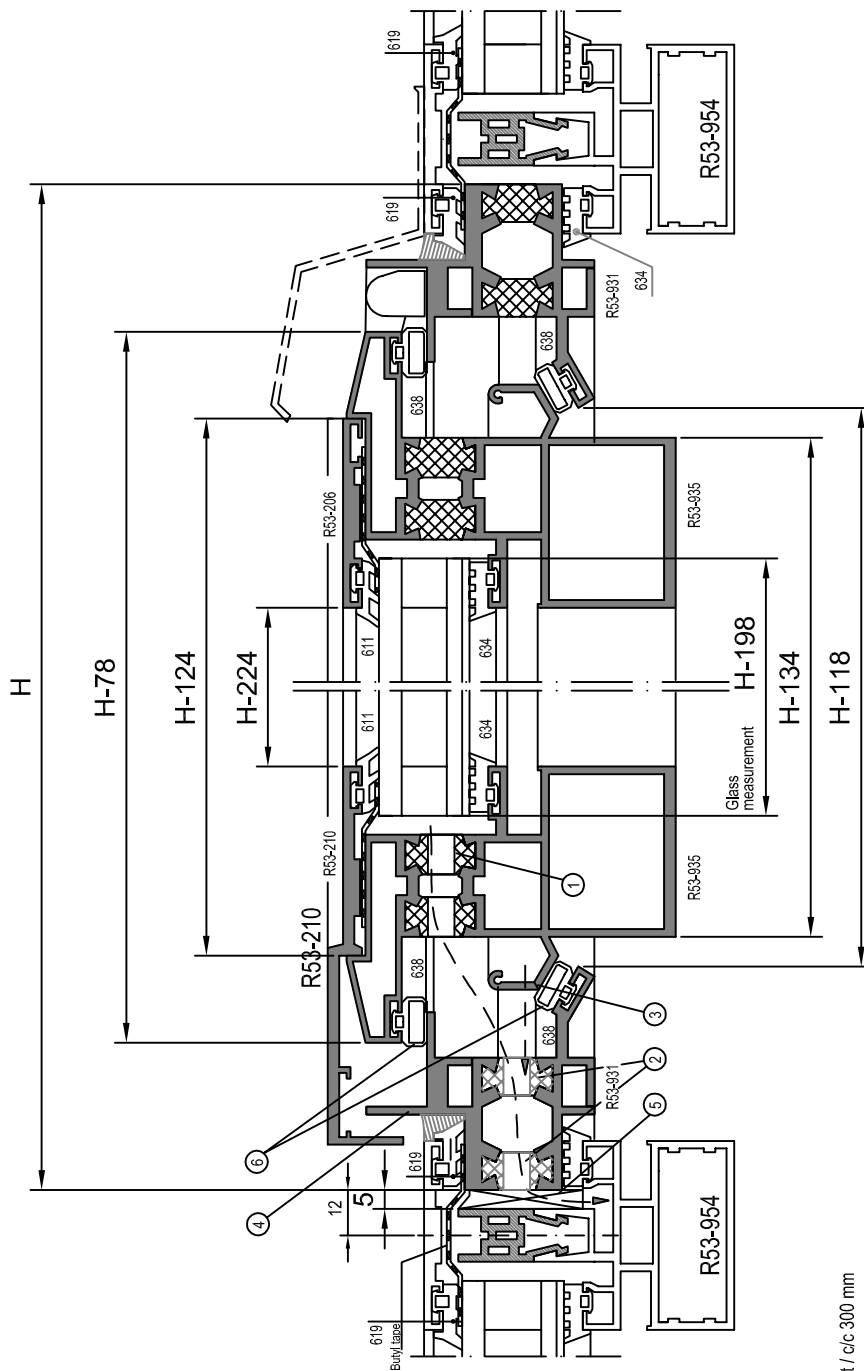

Bleed

- ① \varnothing 18 hole 25 mm from casement / c/c 300 mm
- ② \varnothing 18 hole 25 mm from frame/ c/c 300 mm
- ③ Cut-out 12 x 50 in casement's drip groove, 50 mm from edge / c/c 600 mm
- ④ Cut-out 16 x 20 in lower corners and center of frame's drip groove

Note!

- ⑤ Skylight assembly to Vertex rebate as sealed glass structure. See glazing instructions.
- ⑥ Joint of sealing 638 to center of window's lower edge. Heads of sealing are sized with SICOMET glue.

Opening skylight Vertical section 1:2

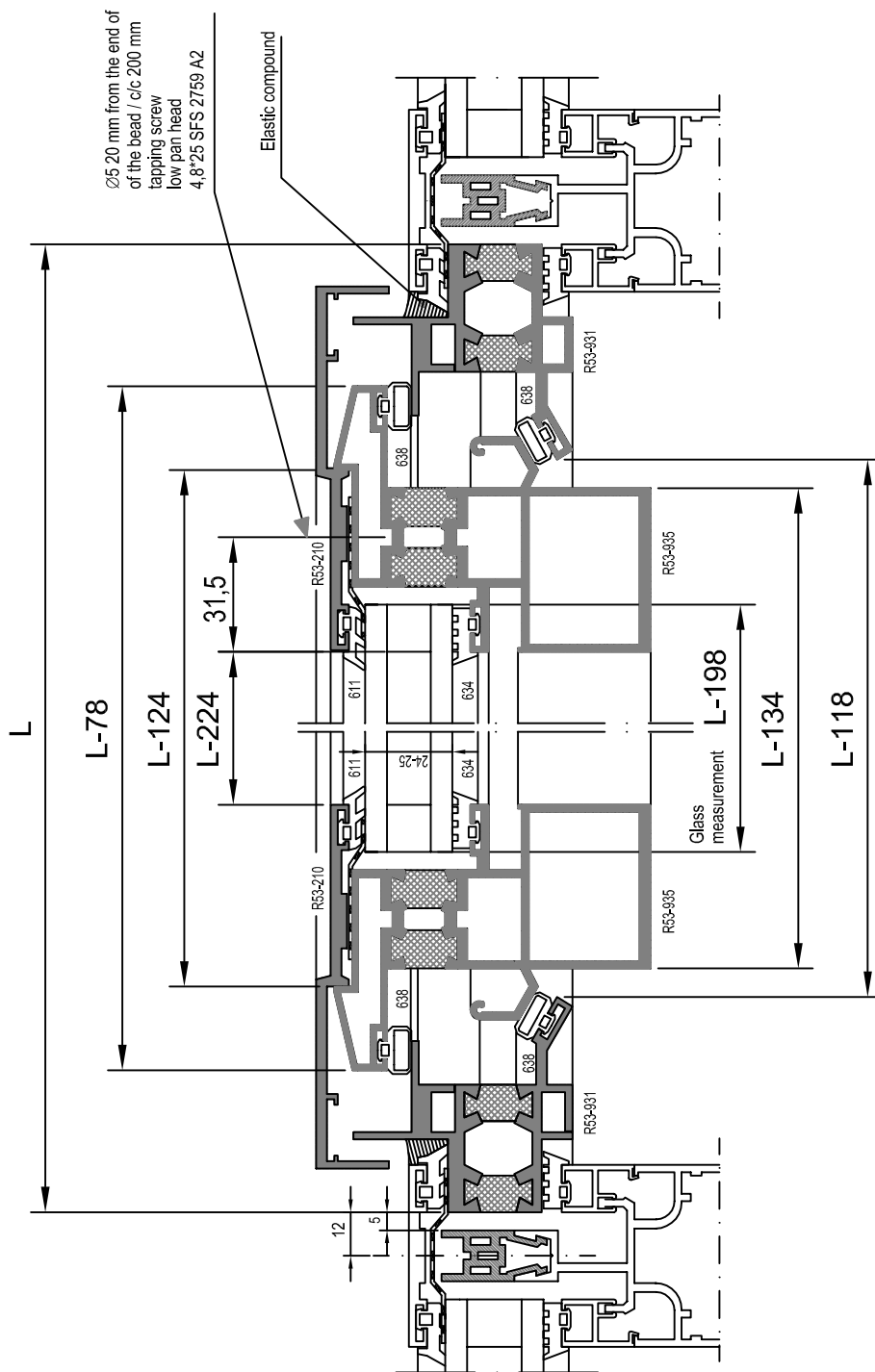

Ø5 20 mm from the end of the bead / c/c 2000 mm tapping screw low pan head 4,8*25 SFS 2759 A2

Elastic compound

L

L-78

L-124

L-224

31,5

Glass measurement L-198

L-134

L-118

12

5

01.07.2013



Opening skylight
Horizontal section 1:2

Glue:
Araldit standard or
Makroplast UK 8205P/
UK 5400

cross-cutted R65-428

R65-802

Elastic polyurethane based
compound on profile
cross-cutting surface

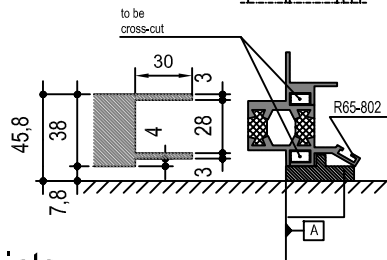
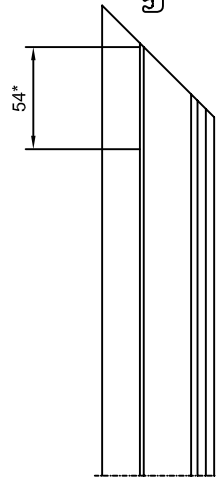

Angle joints

R65-802

R65-821

Glue:
Araldit standard or
Makroplast UK 8205P/
UK 5400

Elastic polyurethane based
compound on profile
cross-cutting surface

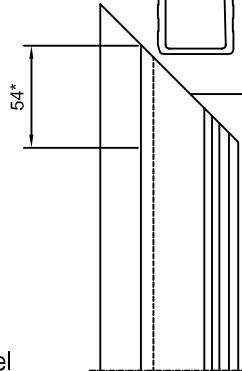

* Bayonet position on A-level

Glue:
Araldit standard or
Makroplast UK 8205P/
UK 5400

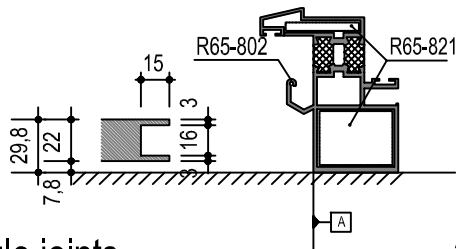

Angle joints

Angle joint of R53-210 glazing bead

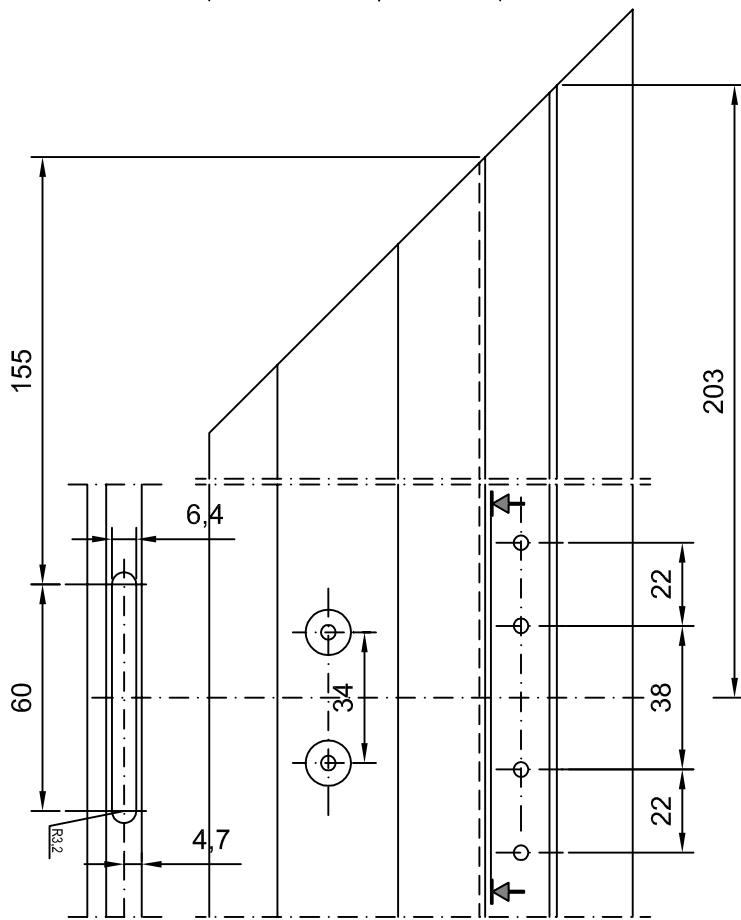
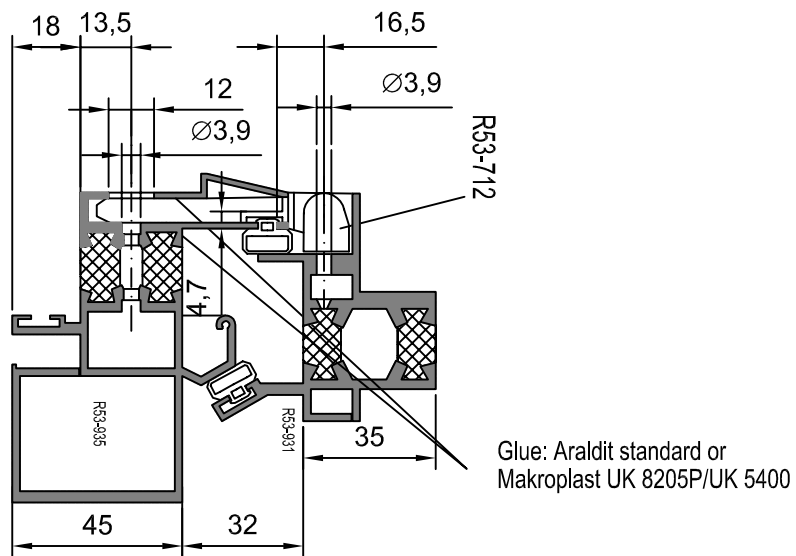

Note! Installation of heat and smoke venting devices in according with manufacturer's instruction.

01.07.2013

R53
VERTEX

22

NOKIAN
PROFILES

Opening skylight
Hinge fastening and machining 1:2

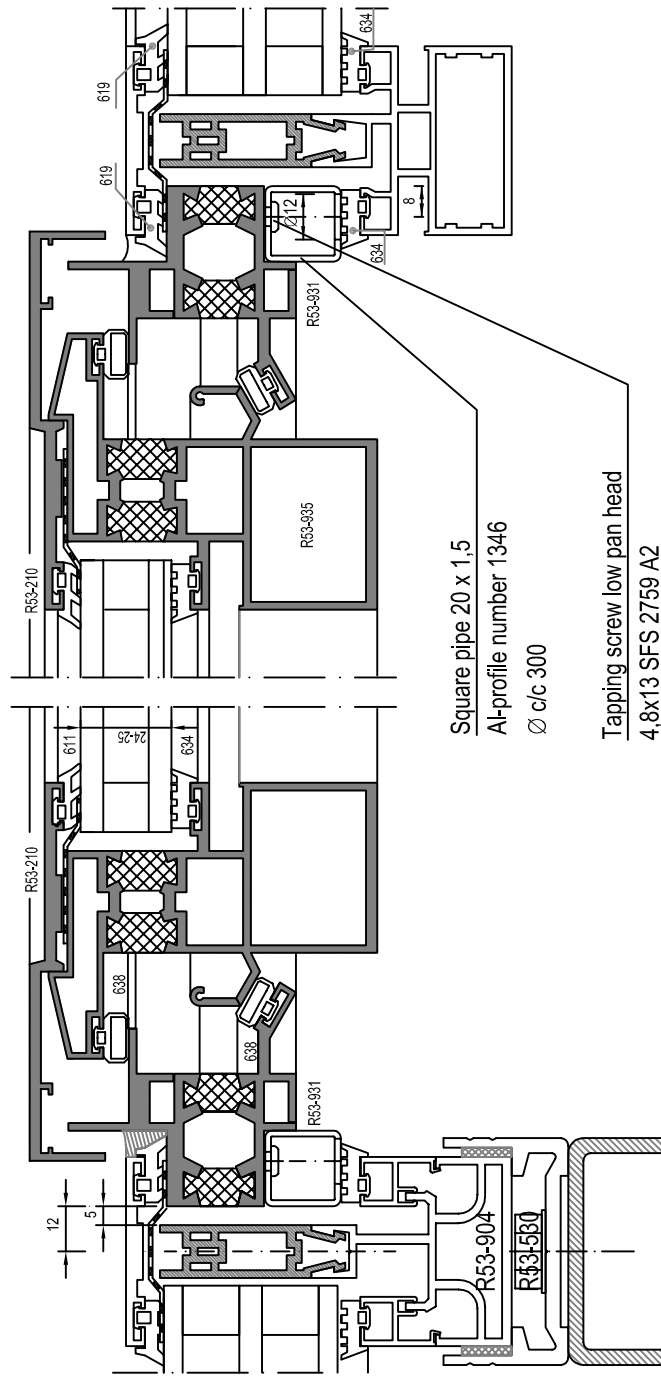

Joining with separate frame 1:2

Joining with triplex structure 1:2

Opening skylight, jointing with separate frame
and jointing with triplex structure

01.07.2013

MOTOR OPERATED

Mountings

-twist rivet M6 + screw

Control automatism

- Control center max. 10 engines/centre
- Transformer for engine
- Control switch for single / group control
- Group center with alarm automatism
 - connection for ex. at fire station
- Rain sensing device
- Wind sensing device
- Smoke indicator
- Fire indicator
- Fire alarm handle

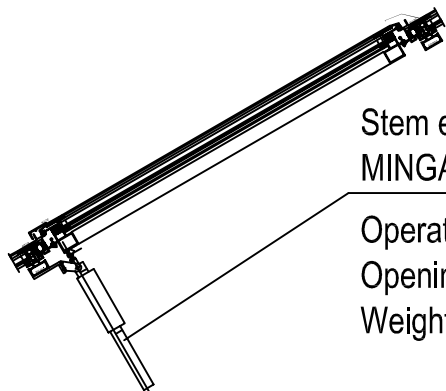
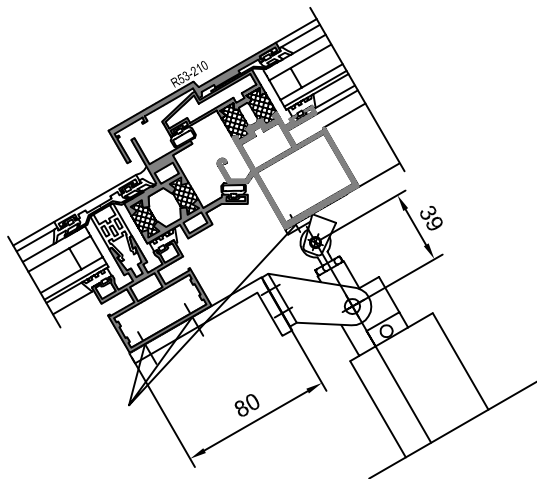

Stem engine

MINGARDI-MAGNETIC (Stig Wahlström Oy)

Operate voltage 24 V DC

Opening 180...1000 mm depending on type

Weight of shutter -with one engine max. 80 kg

-with two engine max. 160 kg

HAND OPERATED

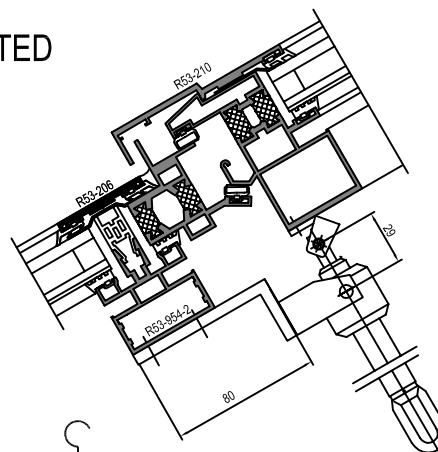

Hand opening device Mingardi Magnetic
(Stig Wahlström Oy)

Opening 310...500 mm

Arm L=100...300 mm

01.07.2013

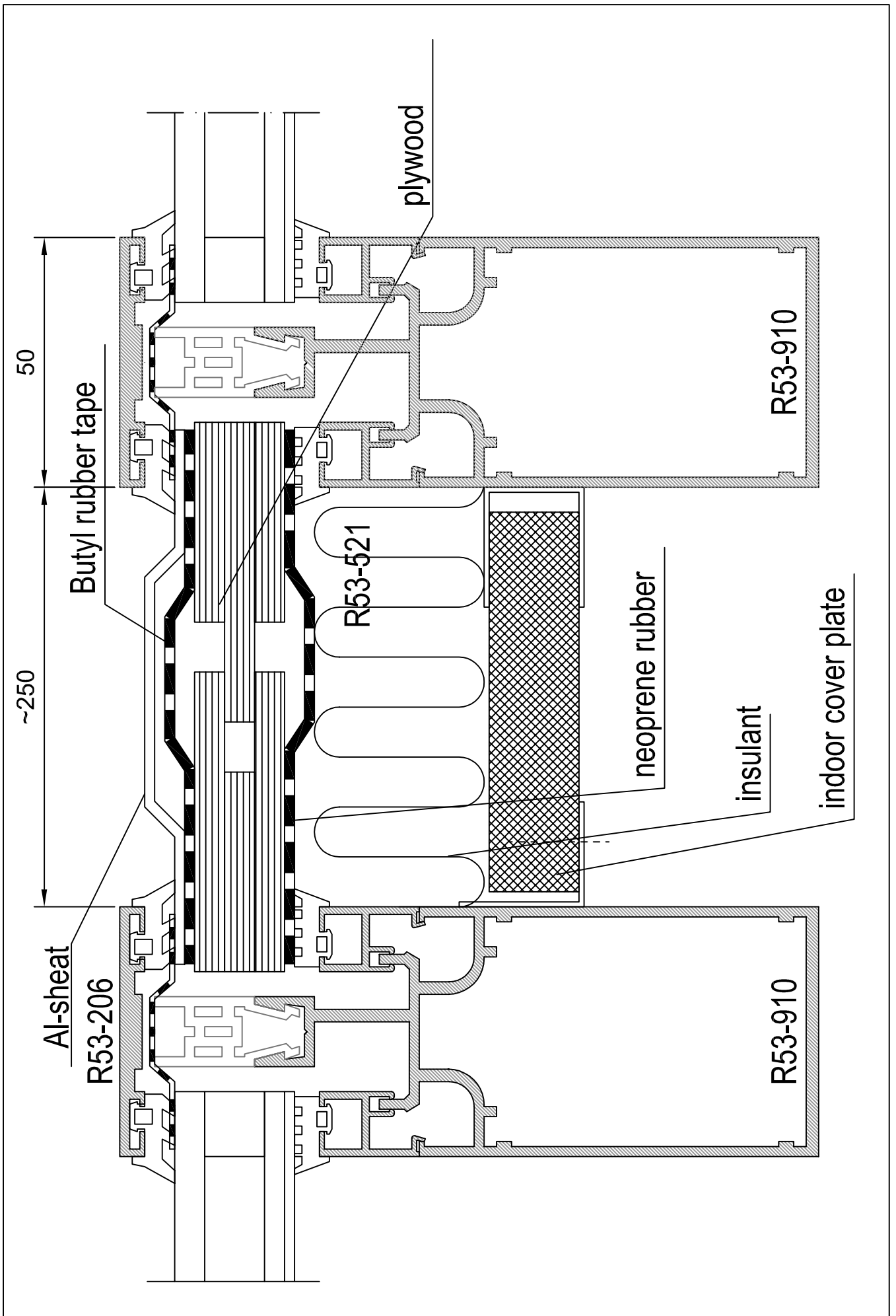

Installation

Great care must be used when installing glass and insulation glass onto roofs. The installation base must be completely straight and the contact with the glass must be good. The sealing materials used in the installation must be compatible with each other and must not create any chemical reactions. Care must be used with the edges of the glass, since damaged edges have a major impact on the durability of the glass. The glazing bead profiles are attached with a steady force, using a torque wrench, for instance.

When starting the glazing, make sure that the rebates, glazing beads and glasses are clean. Condensation and run-off water grooves must be clean and open and the thickness of the glass must be correct.

Sealing tape 643 is set into place and the corners are secured with elastic compound. When cutting the sealing tape, it must be kept in mind that there is a possibility of 5 mm/m longitudinal shrinkage.

Installation of glass

The purpose of the pads is to support, center and carry the sealed glass or similar in the frame in the intended manner. With the bearing pads, the weight of the glass is partially shifted to the frame structure. Ensure that the pads remain in place. The bearing pads must be made of a shape-retaining and durable plastic with a hardness of 70-90° Shore A, or another suitable material for the purpose.

Pads made of other material must be of an equal hardness. A disjointable or folder pad can not be used.

The temperature fluctuations that the R53 VERTEX structures may be susceptible to must not effect the hardness of the pads. The length of the bearing pads must be 100 mm, and the width of the pad must be 4 mm wider than the thickness of the glass pane. The thickness of the bearing pads is 5 mm. A pad must also be under the outermost glass. The length of the support pads can be 50...100 mm depending on size of glass pane, and the width of the pad can be same as the width of the bearing pad. It must be ensured that the supporting pads remain in place. The bearing and supporting pads must not block the run-off water grooves at any point. The pads are installed 100 mm from the corner of the pane (measured to the center of the pad).

Instead of heat-insulating profile under the pads of heavy glass, it is recommended to use a piece (approx. 200 mm long) of the R53-520 profile. In triplex-structure is used pad R53-603.

These glazing introductions are a matter principal only. Naturally, we are not responsible for the actual glazing work which we do not control.

The EPDM sealing compound tape we supply is very heat and age-resistant. We are not responsible for the sealing compound materials. The thickness and types of glass must be specified separately with the glass manufacturer. Special instructions, e.g. RIL 198, Light permeable structures. Note the thickness of the glass packages. Roof glazing instructions are valid for areas 5-75°. Transparent structure 75-90° are window structures.

How to glaze R53 VERTEX-profiles

Rectangular roof and oblique angled applications

- Ensure that condensation and leakage grooves are clean
- Ensure that the frame structure joints have been done in accordance with NOKIAN's instructions (work shop files)
- make sure that the corners of the T-joint are sealed; there must not be any putty in the leakage or condensation grooves, only and especially in the places where it is specified (engine shop file).
- Mount interior vertical glazing profiles R53-52X into place.
- Mount interior glazing sealing 643 into place; putty the sealing corners with the glass manufacturer's recommended elastic compound.
- set glazing pads into place, 100 mm from the edge of the glass to the center of the pad. Pads must not block leakage water grooves. Use elastic compound to ensure that the pads remain in place.
-THE USE OF A DISJOINTABLE OR FOLDER PAD IS STRICTLY FORBIDDEN.
Under heavy glass, it is recommended to use 200 mm long pieces of profile R53-520 at the pad position (double structure), triplex structure R53-603.
-Asymmetrical pads (e.g. in barrel vaults) shaped from weather-resistant formwork plywood.
- The thickness of the glass must be measured in accordance with NOKIAN's instructions; glass thickness 4-8 mm in simplex structures, 25-27 mm in duplex structures, and 45-48 mm in triplex structures.
THESE THICKNESSES ARE MINIMUM.
-The manufacturer must determine the correct (e.g. RIL 193-1993) thicknesses of individual glass elements included in sealed glass packages in each instance.
- Lift the glass to the light opening area and center it in the opening using the supporting pads.
- Install butyl tape into place (e.g. using a rubber roller).
- the surface of the glass must be absolutely dry and clean to ensure that the butyl adheres.
- The adherence of the butyl tape and the success of the glazing cannot be guaranteed in temperatures lower than 0° C.
- Pull the butyl tapes at the X- and T-joints over each other to ensure the corners are sealed.
- install the glazing sealing to the exterior glazing bead R53-2XX.
- the sealing tape must not be stretched when applying it; remember that there is a longitudinal shrinkage possibility of approx. 5 mm/m.
- Cut the sealing tape at a slant to prevent overlapping of the sealing "legs".
- First mount the vertical glazing bead profiles into place.
- Open the holes in the butyl tape at the glazing bead screw positions to prevent rotation of butyl tape around glazing screws.
- Attach the glazing bead stainless special anchoring screws in sequence starting from the end of the profile to ensure the seal.
- Mount the vertical glazing profiles into place in the same manner.
- Seal the joints of the glazing beads with elastic compound and install cover piece R53-7XX into place according to instructions.
- Extreme caution must be used when glazing so that the structure is definitely sealed.
- Perform the work in the proper sequence to prevent unnecessary stoppages.
- The special RT card instructions must be followed in glazing.
- future information is available from Nokian Profiles.

As the glazier, you are ultimately responsible for the functionality of the structure.

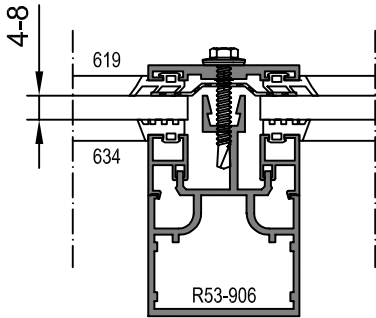

Simplex glass

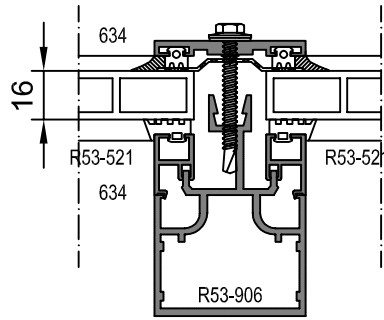

Duplex cell structure

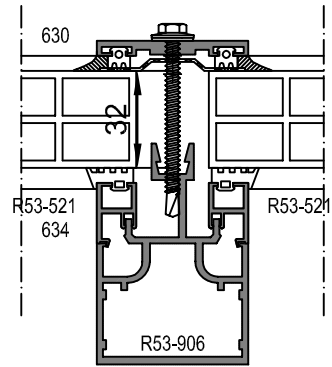

Triplex cell structure

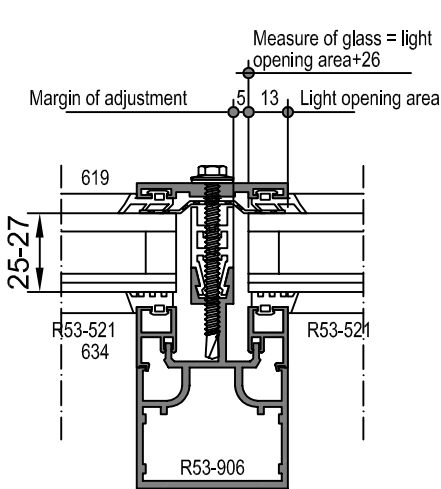

Duplex sealed glass

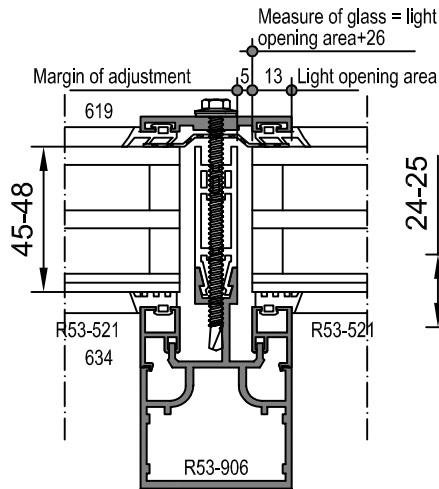

Triplex sealed glass

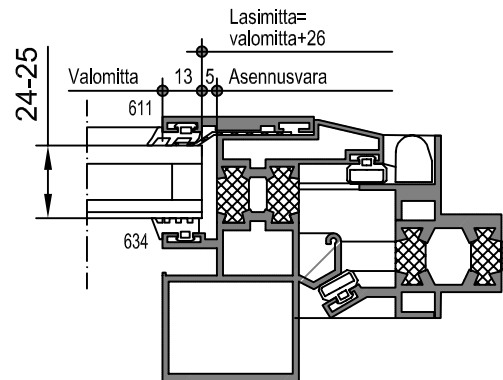

Opening skylight, duplex sealed glass

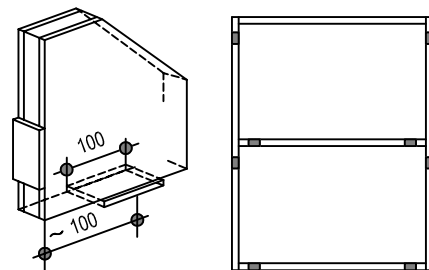
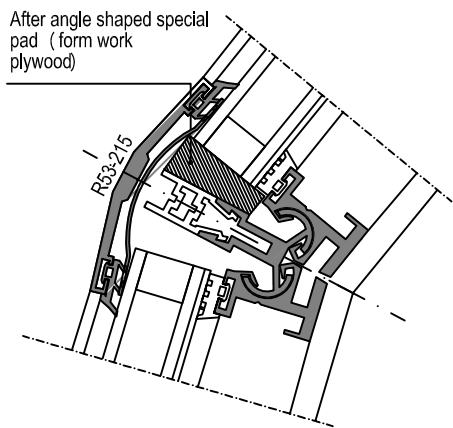

Placement of pads

Sealings

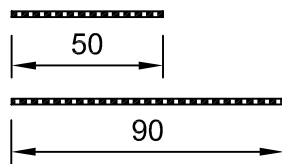
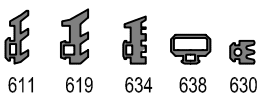

Note! use of butyl rubber tape is necessary in all skylight roof construction

Note! Minimum thickness of glass structures. They must not be degreased.

Note! Glass strength test to be performed in cooperation with glass manufacturer.

01.07.2013

Cover plates

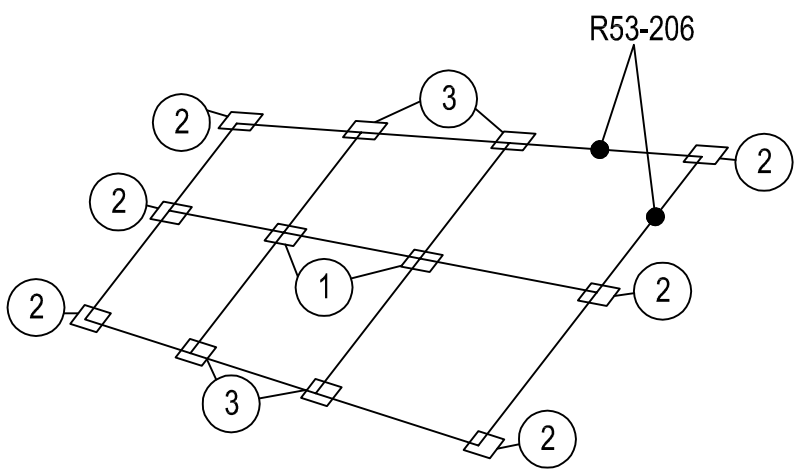
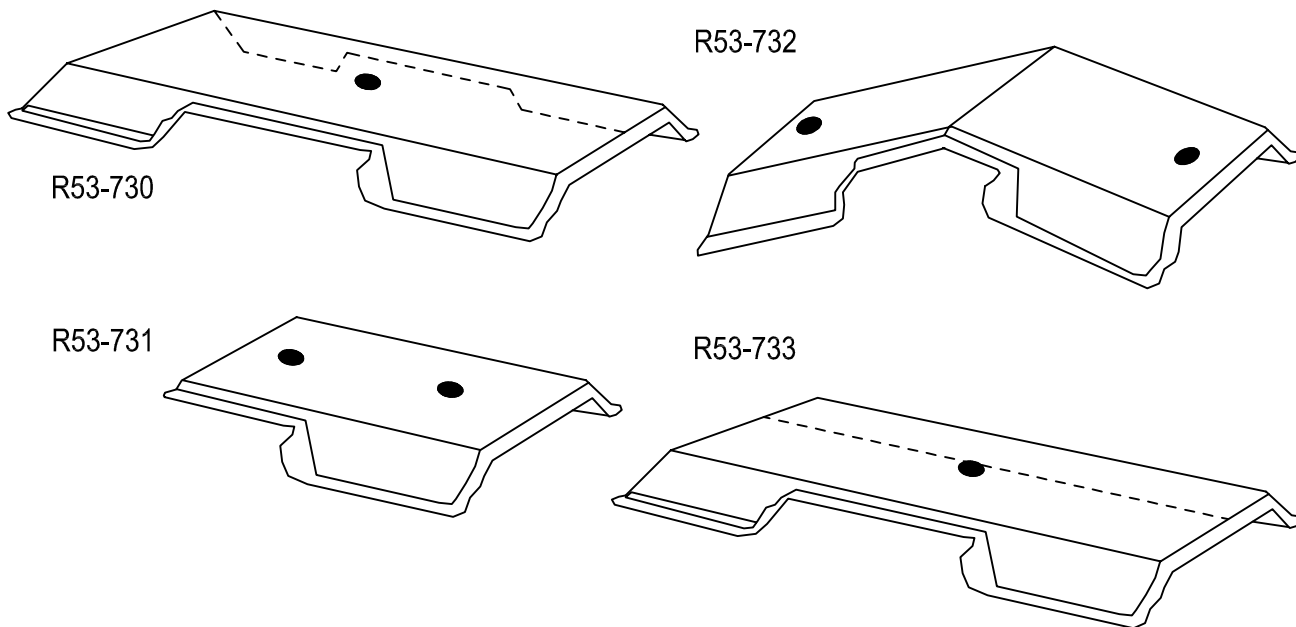

- ① R53-730
- ② R53-731
- ③ R53-733