

3 R12

Contents

1	Profiles, 1:1	23	Panic sliding door, vertical section
2	Profiles, 1:1	24	Panic sliding door, horizontal section
3	Profiles, 1:1	25	Sliding door in R54 system, vertical section
4	Profiles, 1:1	26	Sliding door in R54 system, horizontal section
5	Profiles, 1:1	27	Corner joint with screws
6	Profiles, 1:1	28	Corner joint, crimped
7	Profiles, 1:1	29	Corner joint R12-164
8	Glazing beads, 1:1	30	Corner joint R12-161
9	Accessories	31	Corner joint R12-164 / R12-165
10	Accessories to door or pair door	32	R12-113 joints to profiles with flange
11	Hinges and door closers	33	R12-117 joints to profiles with flange
12	Hinges and door closers	34	R12-108 joints to profiles without flange
13	Installing R72-724 hinges	35	R12-102 joints to profiles without flange
14	Installing R72-722 / R72-723 hinges	36	T-joint of R12-101
15	Installing floor closer	37	Joining treshold R12-504
16	Machining for Abloy lock	38	Joining treshold R12-514
17	Machining for Abloy security lock	39	Corner crimp tools
18	Door latches	40	Glazing instructions
19	Installation of the quick release	41	Glazing bead selection
20	Installation of the edge bolt	42	Work description
21	Sliding door, vertical section		
22	Sliding door, horizontal section		

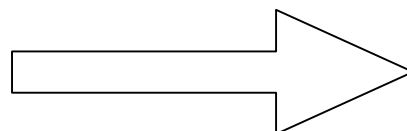

R12 LINEA

43	X-joint
44	T-joint
45	Fixing
46	Glazing bead selection
47	Balustrade, glazing beads
48	Balustrade, fixing
49	Manufacturing door and window
50	Manufacturing door and window, DET A
51	Manufacturing door and window, DET C
52	Manufacturing door and window, DET B

53	Installing door closer
54	Bottom supported sliding window
55	Bottom supported sliding window
56	Top hung sliding window
57	Top hung sliding window
58	Machinings for Abloy lock

R12 BALUSTRADE

59	Glass balustrade, vertical section
60	Glass balustrade, horizontal section
61	Baluster type balustrade, vertical section
62	Baluster type balustrade, horizontal section
63	Hand rail
64	Fixing hand rail to R12 system
65	Post fixtures
66	Installation of fixtures

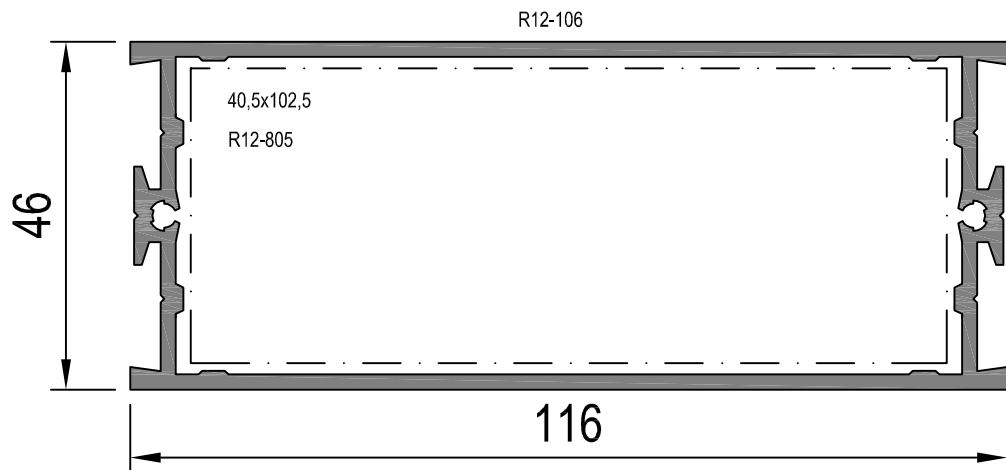
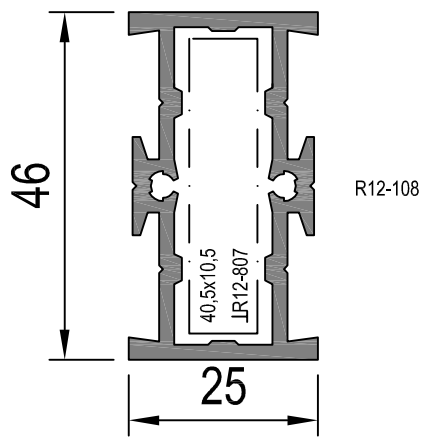
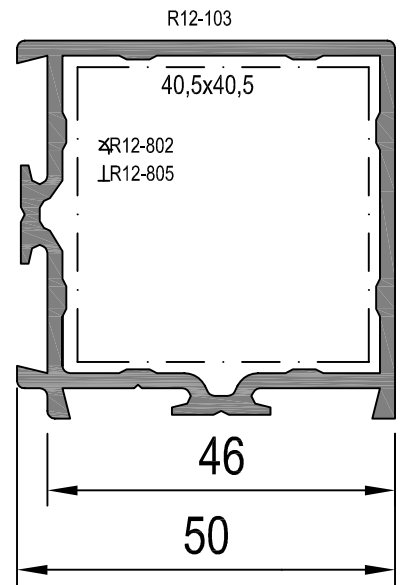
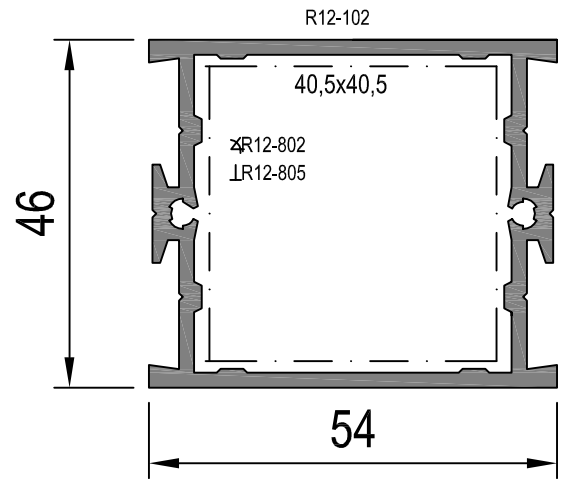
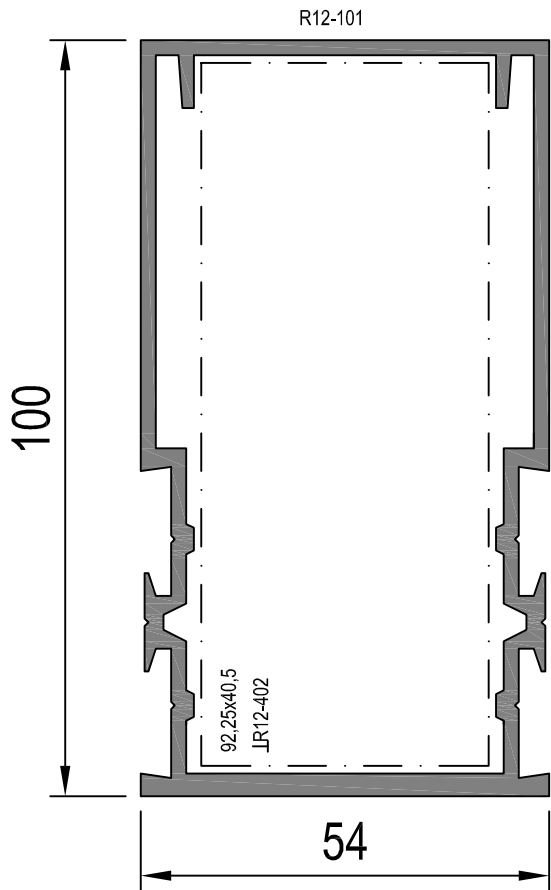

01.07.2013

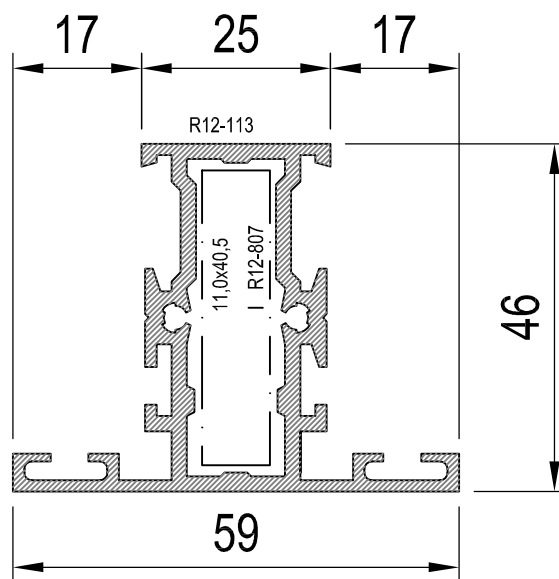
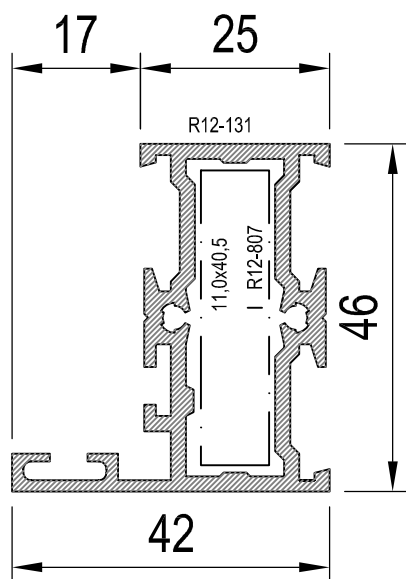
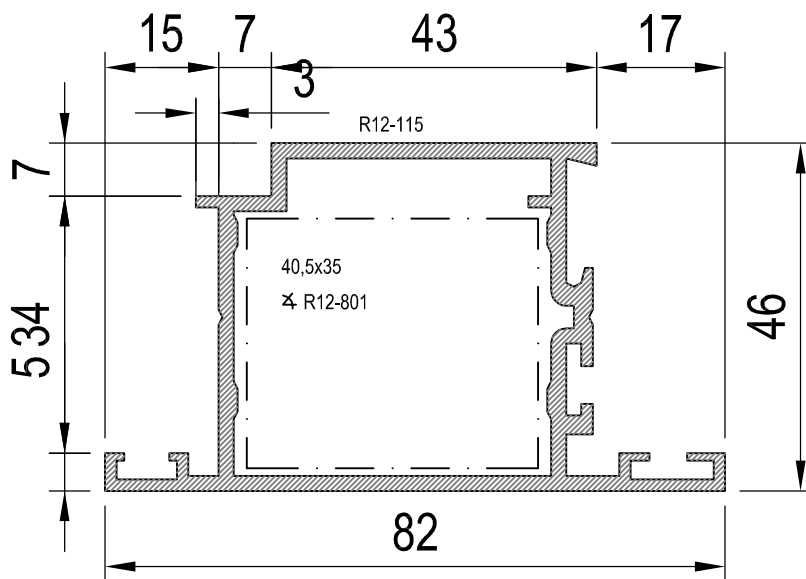
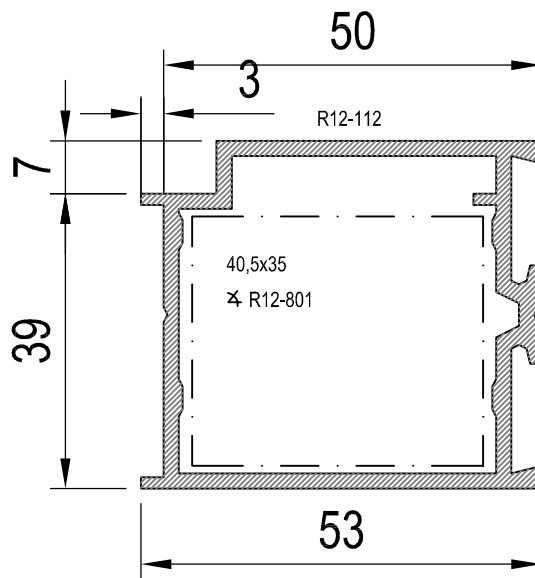
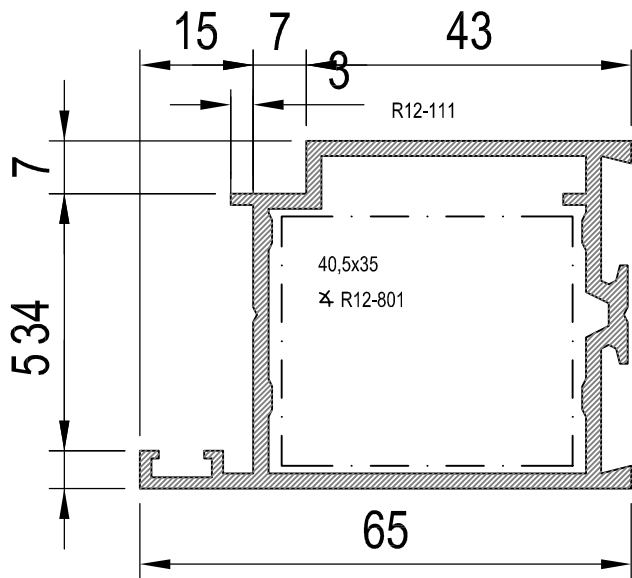

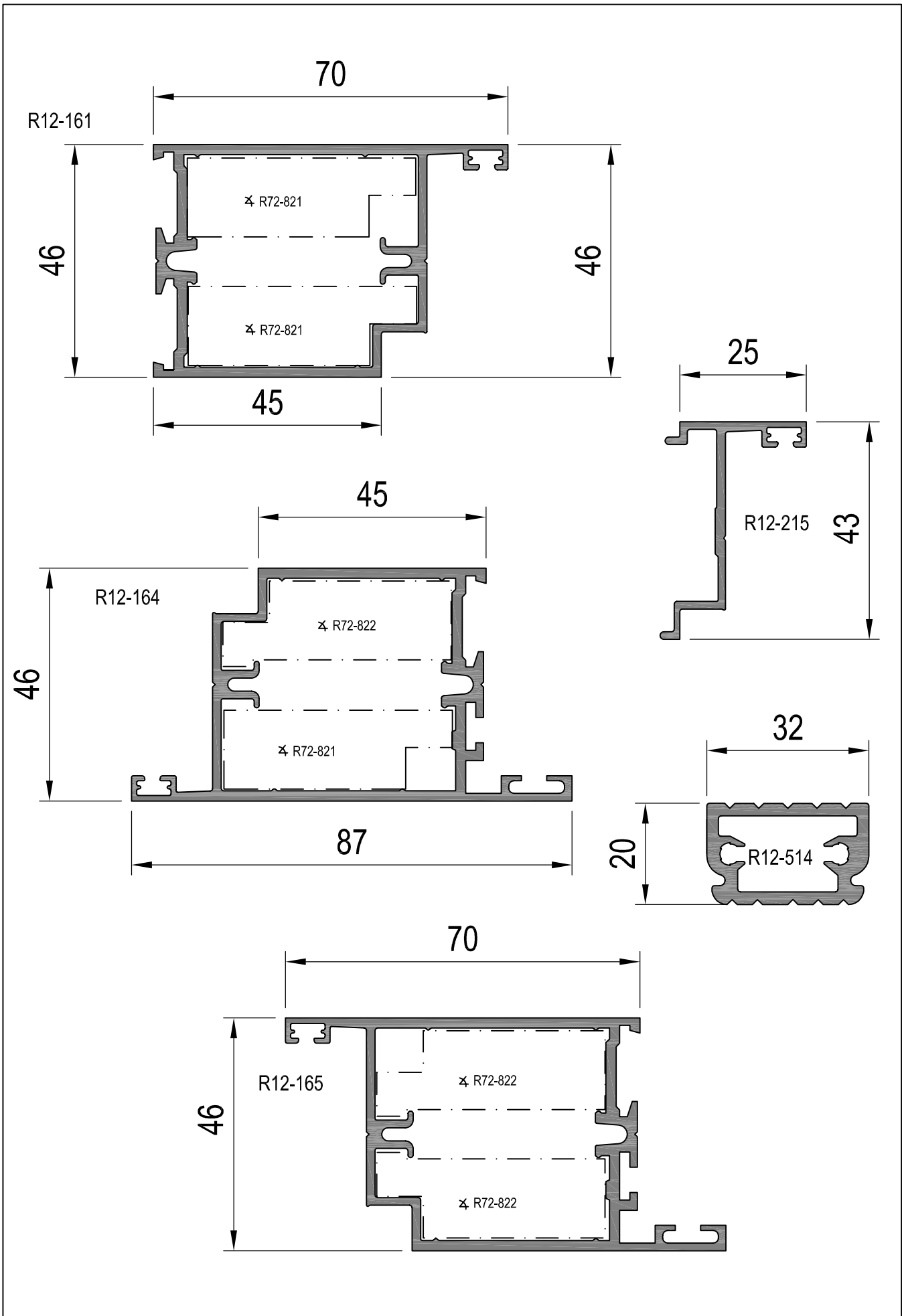

01.07.2013

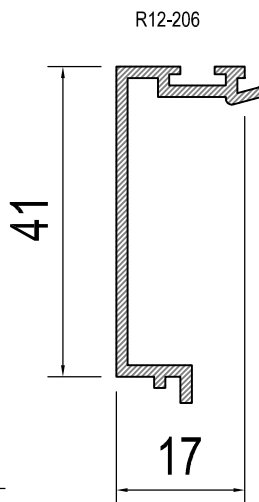
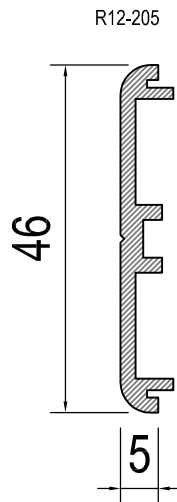
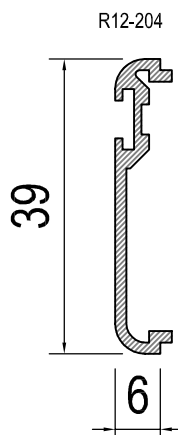
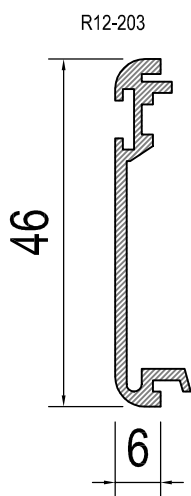
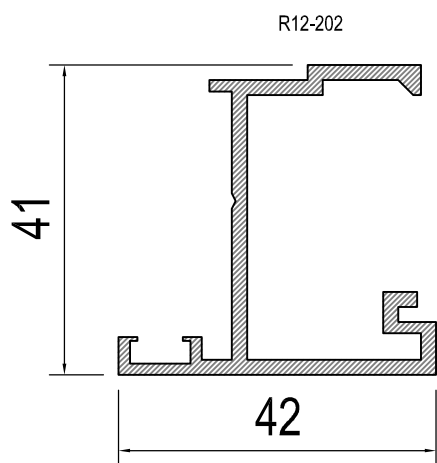
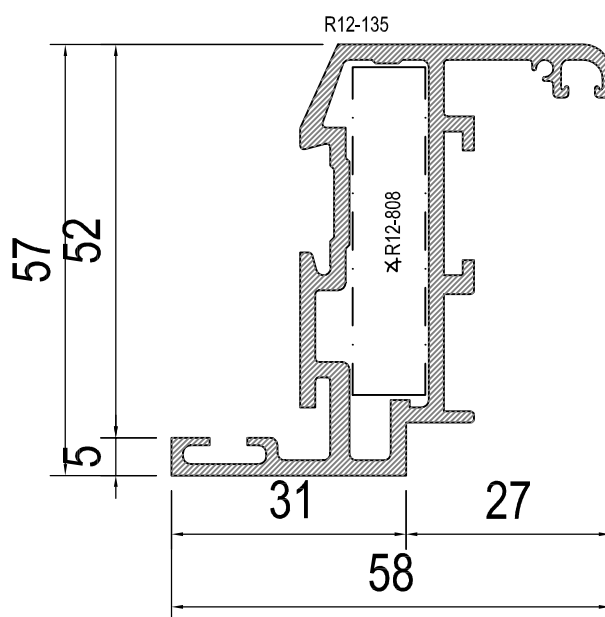
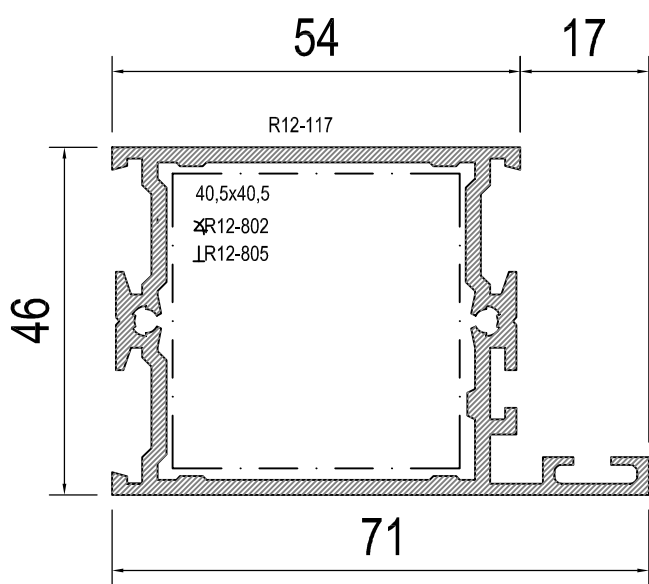
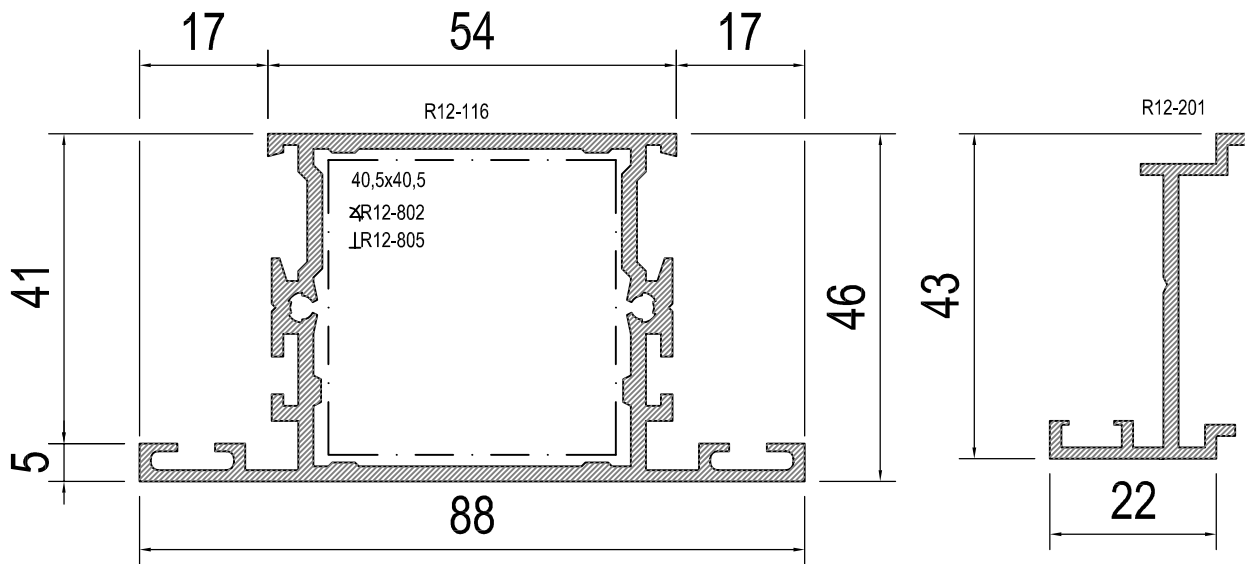

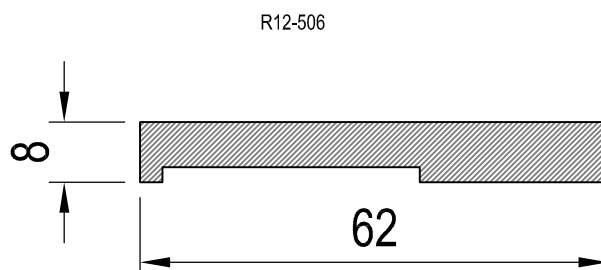
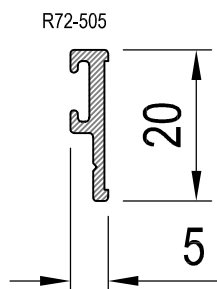
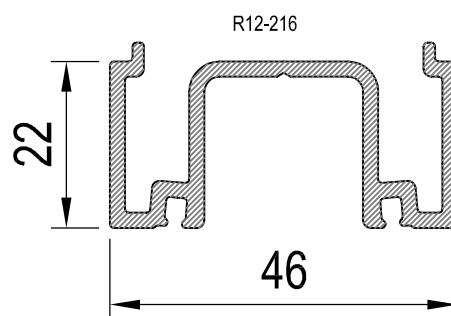
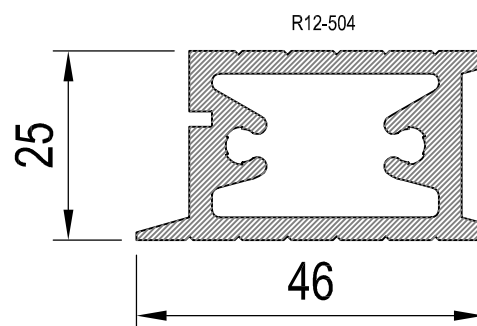
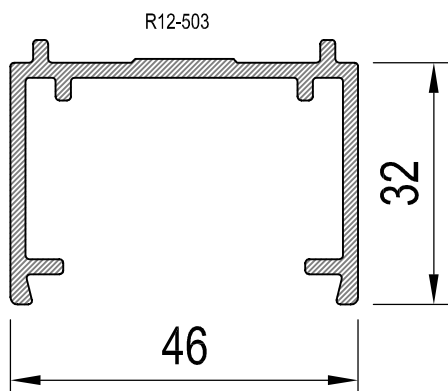
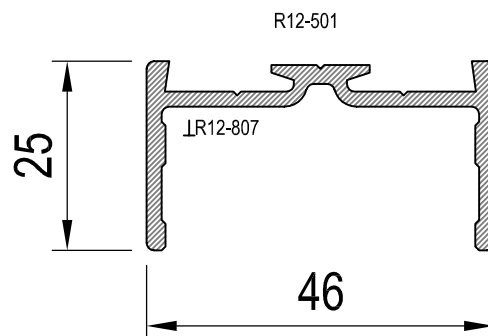
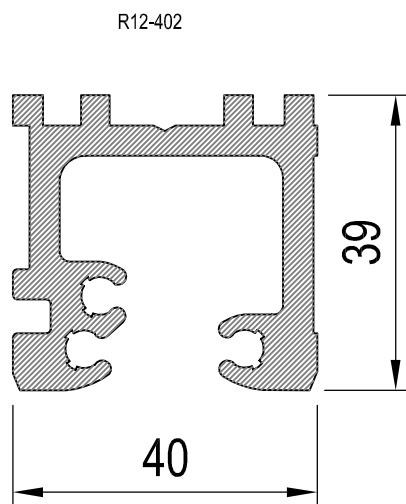
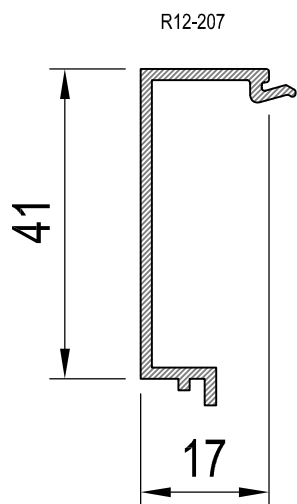

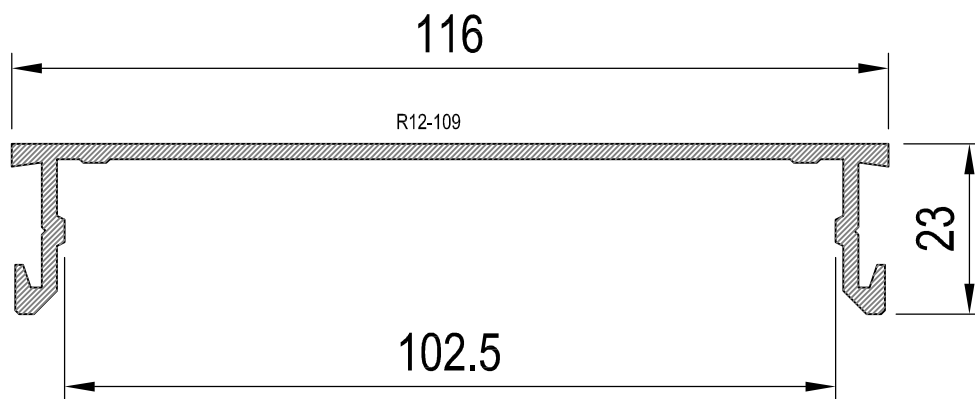
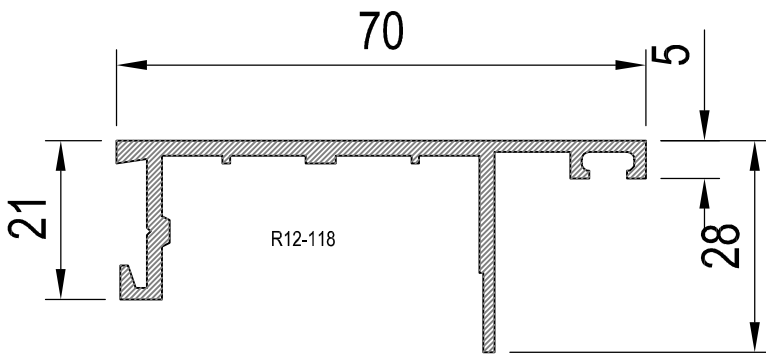
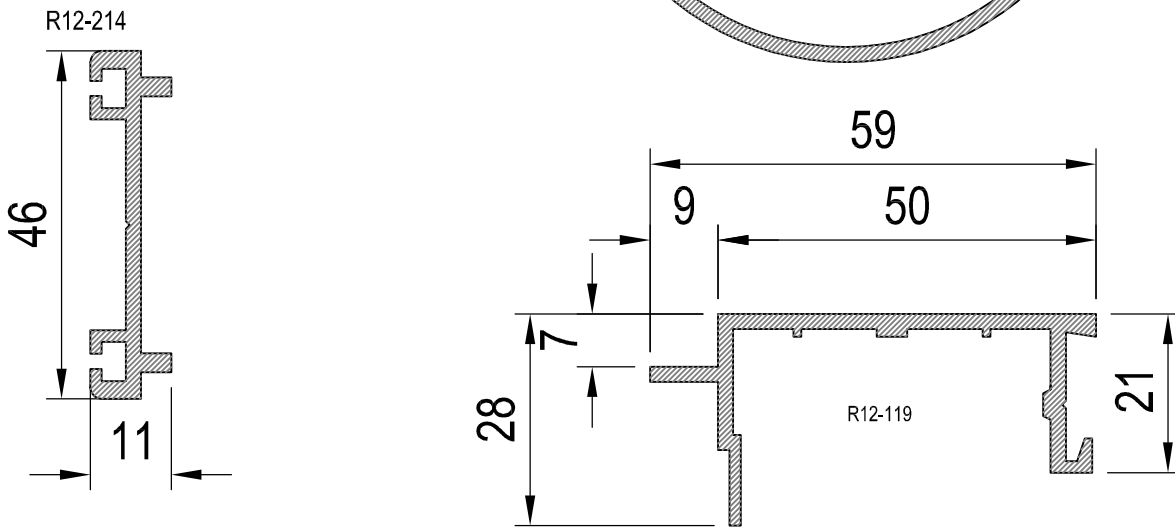
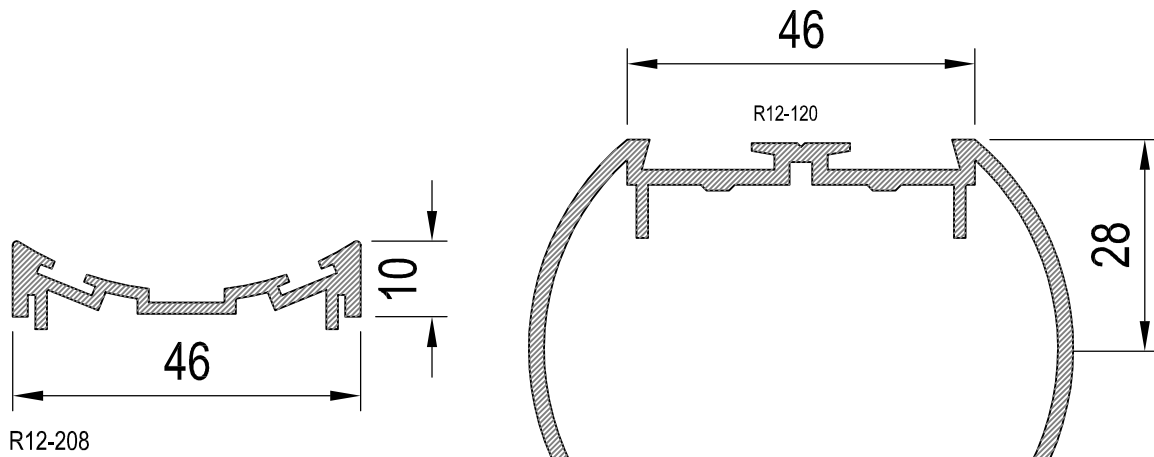

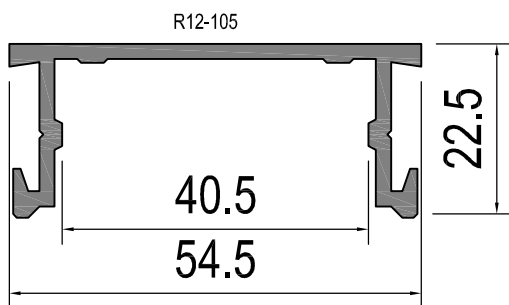
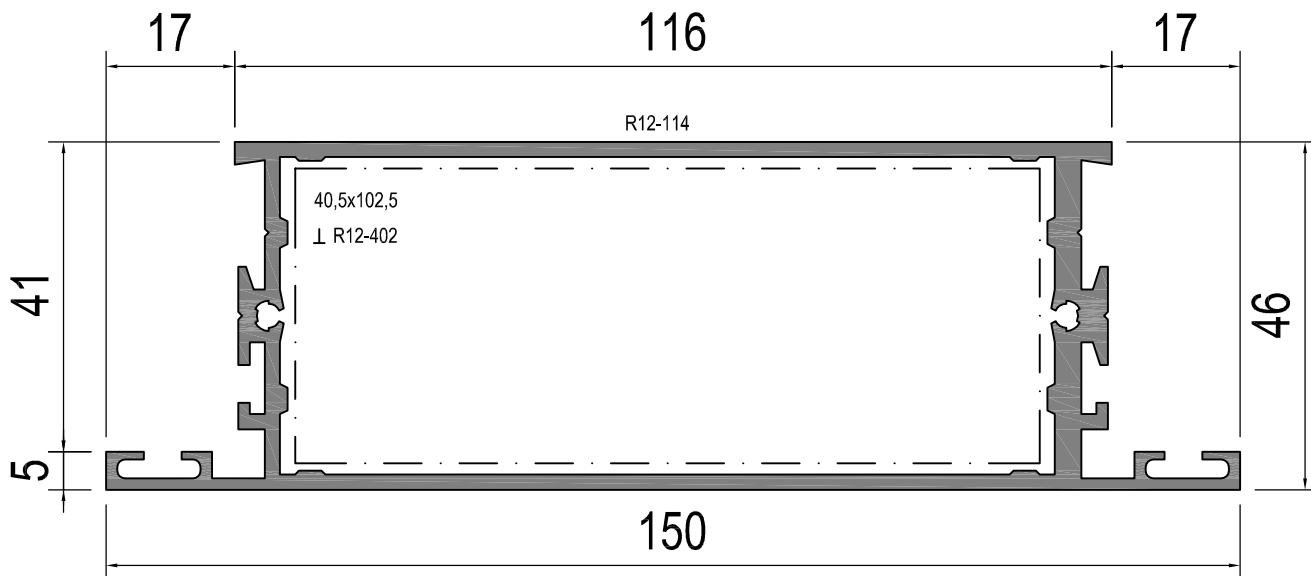
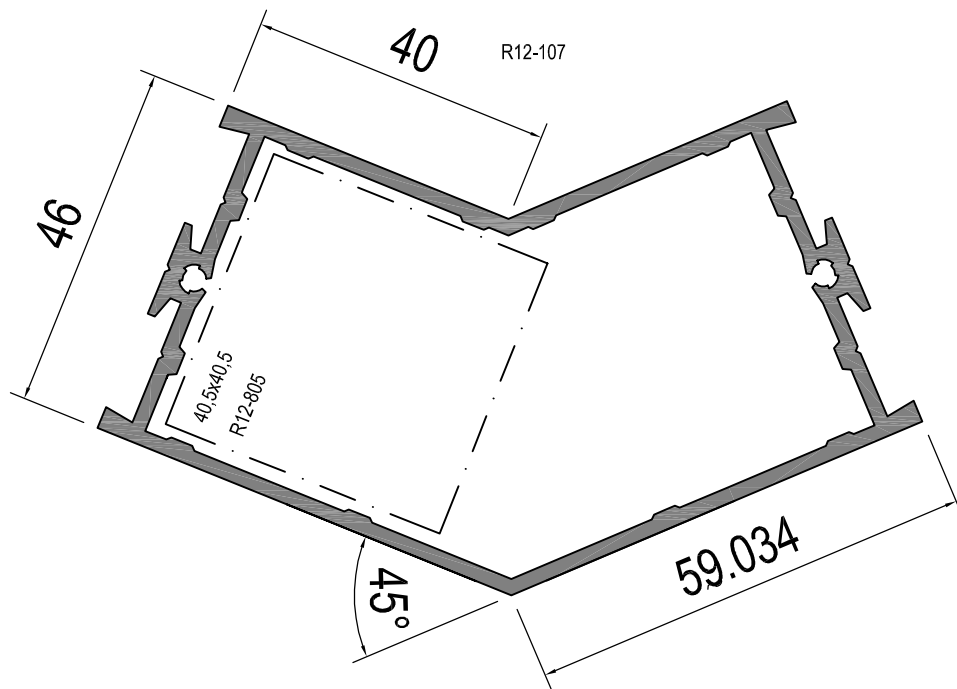

01.07.2013

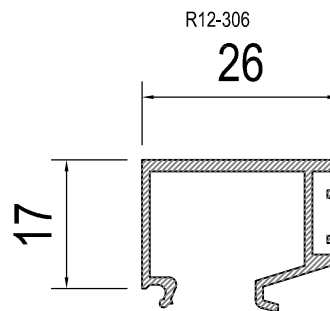
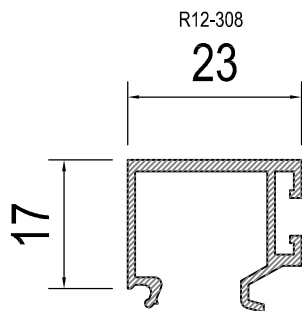
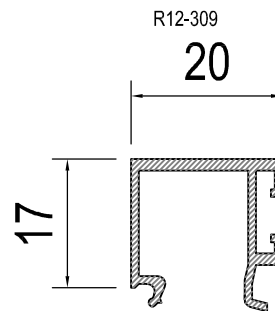
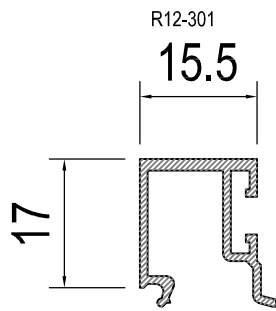
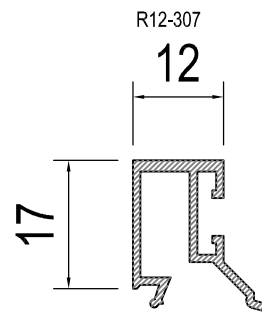
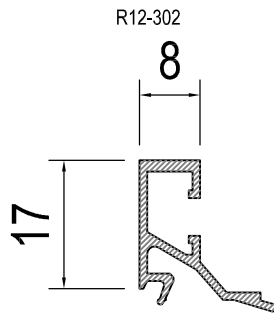
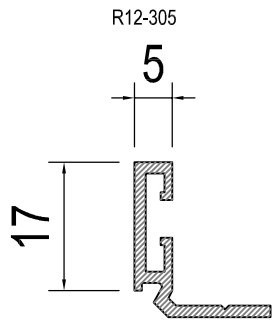

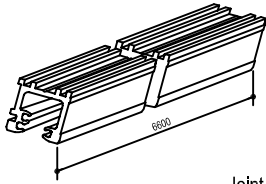

Joint profile
R12-402

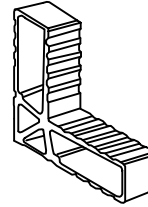

Joint section
R12-802
40,5x40,5 mm

for profiles

R12-102
R12-103
R12-116
R12-117

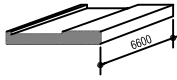

Base plate for closer
R12-506

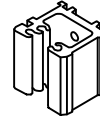

Joint section
R12-805
40,5x40,5 mm

for profiles

R12-102
R12-103
R12-106
R12-107
R12-114
R12-116 2 pcs
R12-117 2 pcs

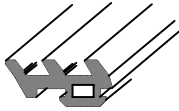

Sealing gasket no 611

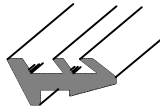

Sealing gasket no 612



Joint section
R12-807

for profiles

R12-108
R12-113
R12-501

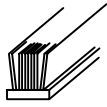

Brush seal no 614

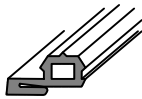

Sealing gasket no 615

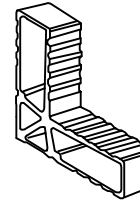

Joint section
R12-801
40,5 * 35 mm

for profiles

R12-111
R12-112
R12-115

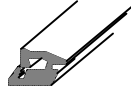

Sealing gasket no 616



Double door lever bolt
R12-727



Double door flush lever bolt
R72-728

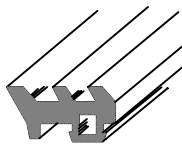

Sealing gasket no 619

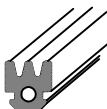

Sealing gasket no 630



Brush seal no 642

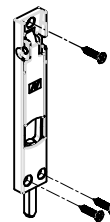

Savio flush bolt (surface mounted)

1157/13

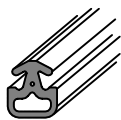

Sealing gasket no 643

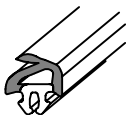

Sealing gasket no 651

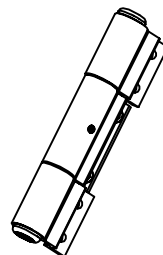

Hinge
R72-722

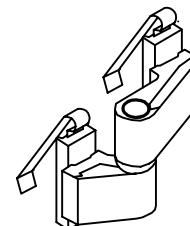

Hinge
R72-724-2 (2-leaf)
R72-724 (3-leaf)

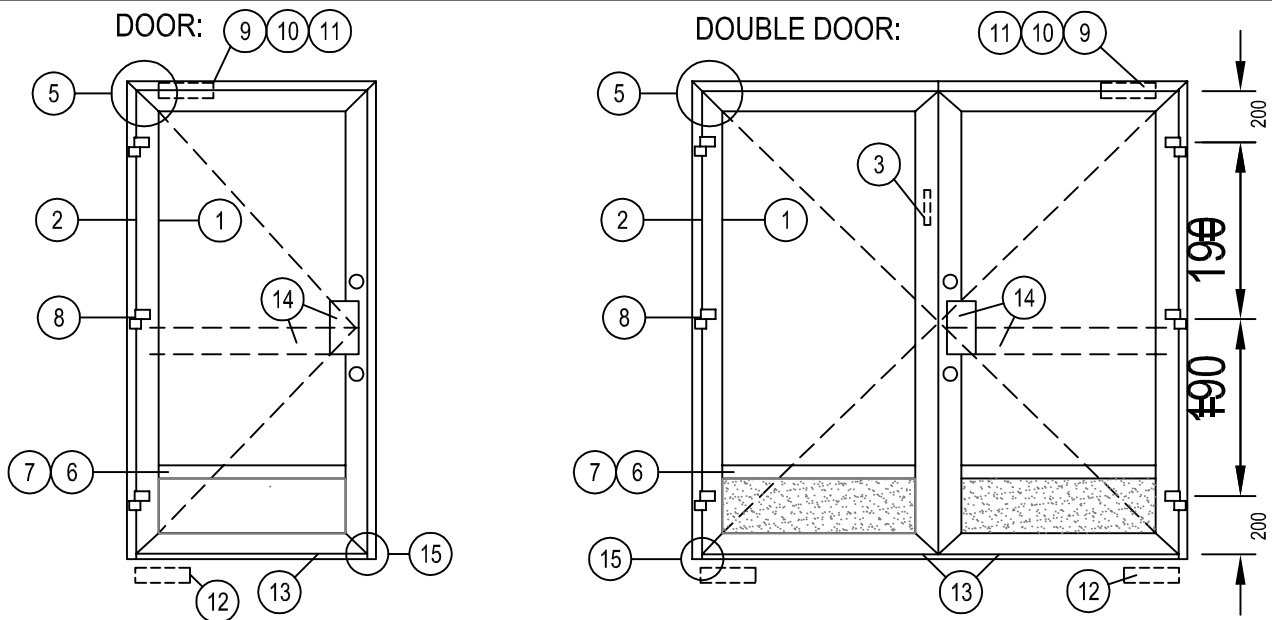

Nr	Item	Nokian order number	Door	Double door	Engine shop file page nr	Note
1	Glazing sealing	611 or 619	m m	m m	R12 29	Glazing in accordance with R12 28
	Retrofit sealing	612	m	m	R12 9	
2	Rebate sealing	616	m	m	R12 9	
3	Double door level bolt or flush level bolt	R65-727	—	1 piece	R12 17	
		R65-728	—	1 piece	R12 16	
5	Angle joint \sphericalangle	R12-801	6 pieces	10 pieces	R12 22	Angle joint for profiles R12-111,-112,-115
6 or 7	Angle joint \perp	R12-805	2 pieces	4 pieces	R12 23	T-joint for profiles R12-102 -106 (2piece) ,-114 (2piece) ,-116 SFS 2759 A2, SFS 2760 A2
	Fixing screws	Tapping screw 4,8x13	4 pieces	8 pieces	R12 24	
7 or 6	Angle joint \perp	R12-807	2 pieces	4 pieces	R12 23	T-joint for profiles R12-108 -113,-501 SFS 2760 A2
	Fixing screws	Tapping screw 4,8x9,5 Tapping screw 4,8x13	2 pieces 2 pieces	4 pieces 4 pieces	R12 24	
8	Hinge	R72-722 or R72-724-2 or R72-724	2-3 pcs	4-6 pcs	R12 8	
			2-3 pcs	4-6 pcs	R12 9	
9 or 10	Door closer or Door closer	Dorma TS 83 Abloy 834	1 piece	1 piece	R12 10	External doors
10 or 9	Door closer Door closer	Roca DC 843/844	1 piece	1 piece	R12 10	Internal doors
11	Support plate profile	R12-506	m	m	R12 10	Baseplate to be manufactured according closer type and left/right-handed type
12	Roca floor spring Savio swing arm 1477 +1129.802 Savio upper hinge 1146.13	Roca DC 843/844	1 piece	piece	R12 11	
13	Profile+ brush	R72-505 614	m	m	R12 3	
					R12 5	
14	Knob		piece	piece	R12 16	
15	Fixing screws for threshold	Tapping screw 4,8x19	4 pieces	4 pieces	R12 26	SFS 2759 A2,

01.07.2013

R12 10

NOKIAN
PROFILES

Door accessories

Door hinge
R72-724

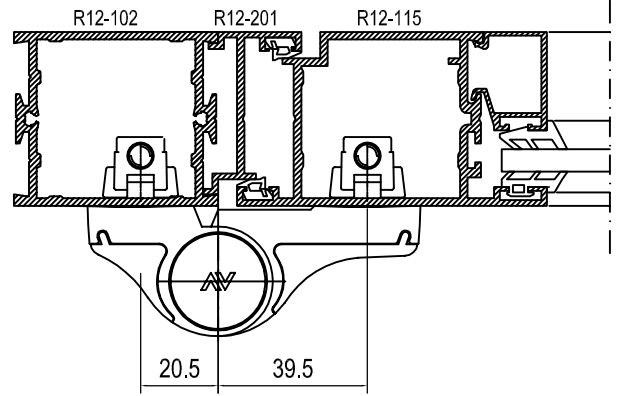
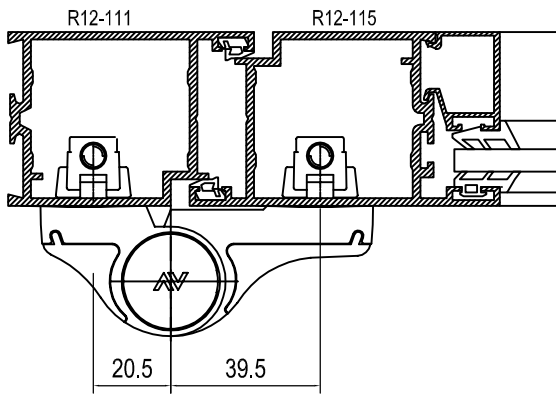

Floor spring Roca DC 843 / DC 844

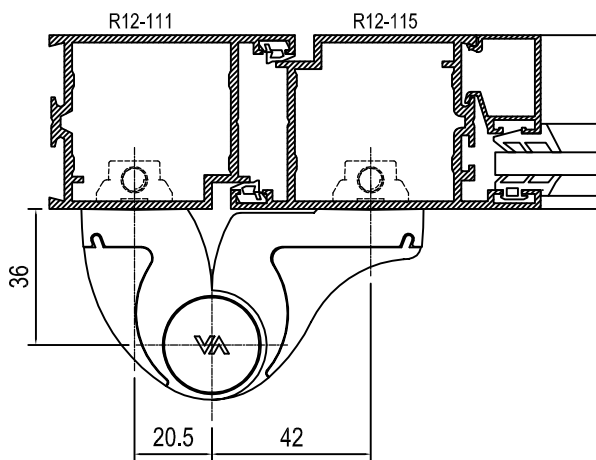

Door hinge
R72-722

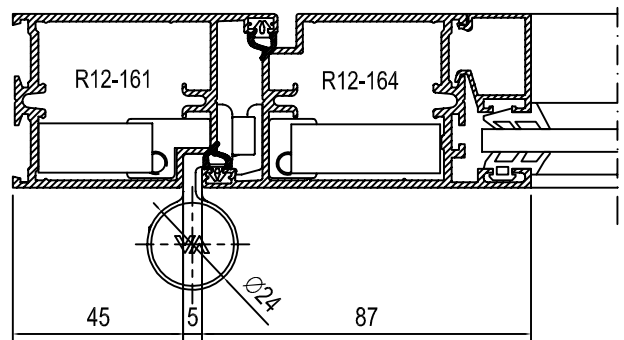

Upper hinge 1146.13 / 62.5 when
Using floor spring

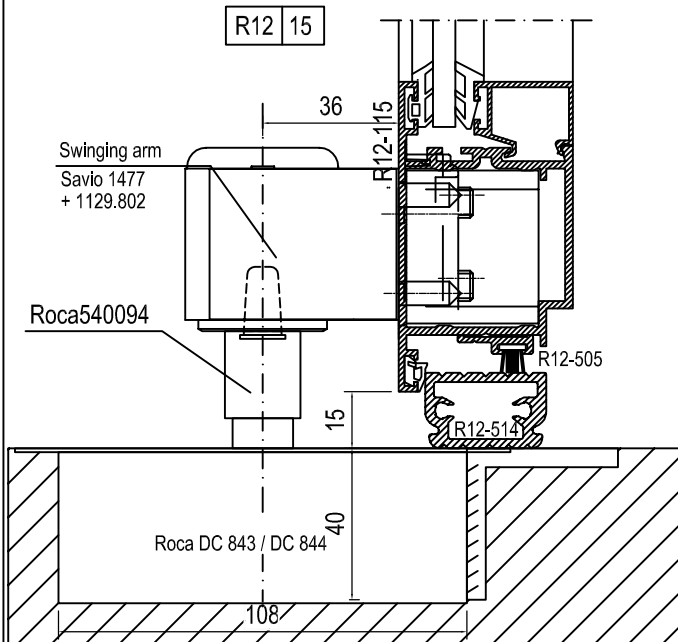

Door hinge
R72-723

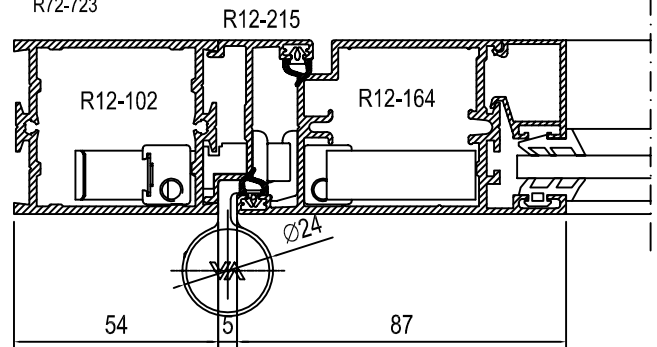

Note. Selection of closers, installation and adjustment according to manufacturers instructions.

Internal door closer Abloy 923 935 AJ (controlled springback factor)

External door closer Abloy 924 AJ

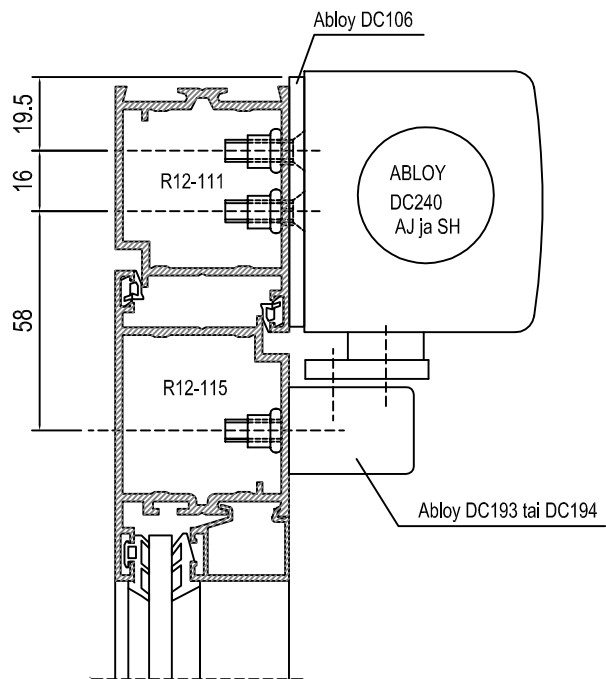
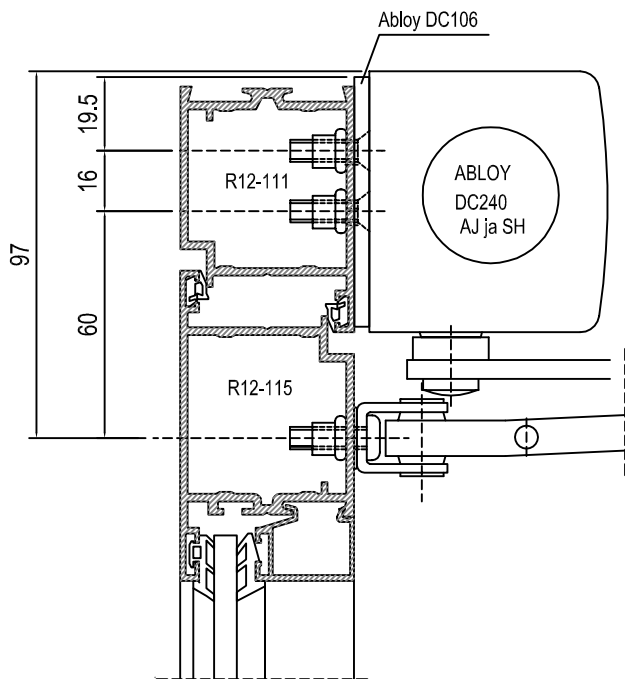
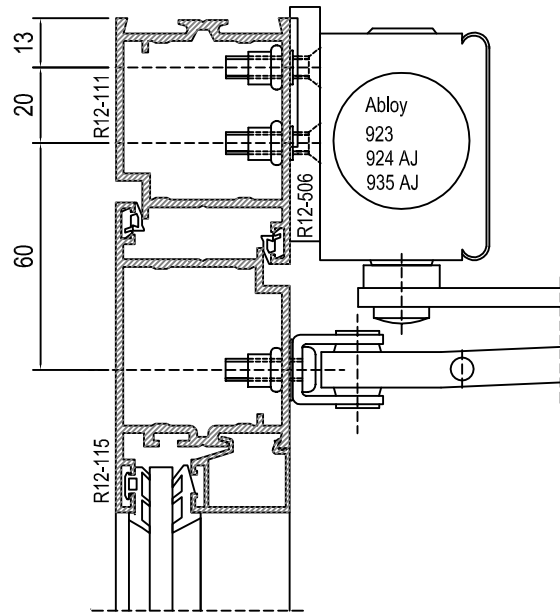
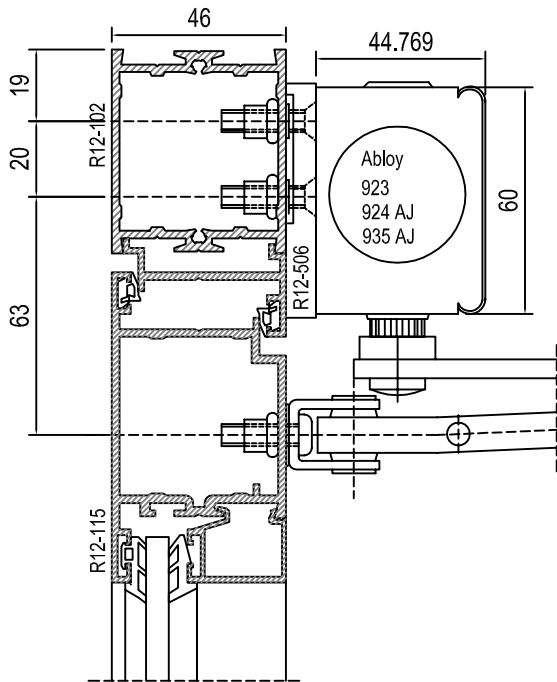

01.07.2013

R12

12

NOKIAN
PROFILES

Door hinges and closers 1:2

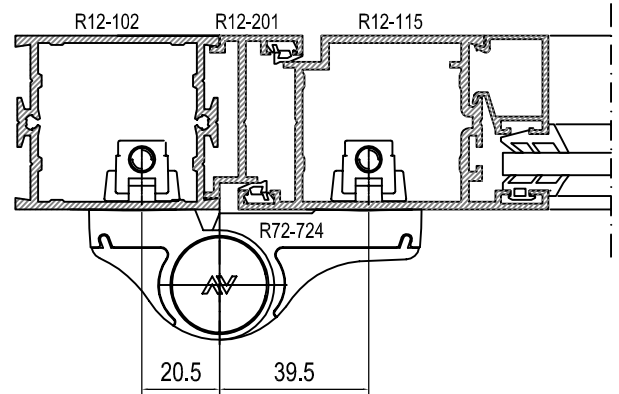
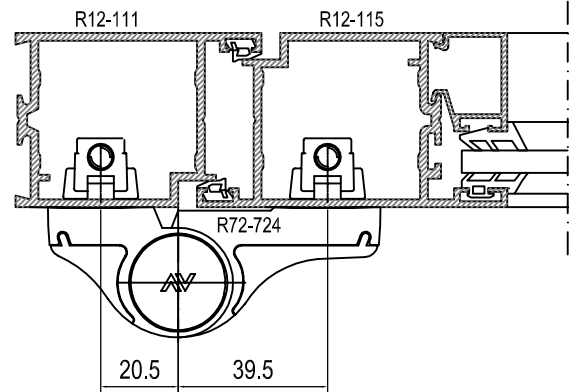
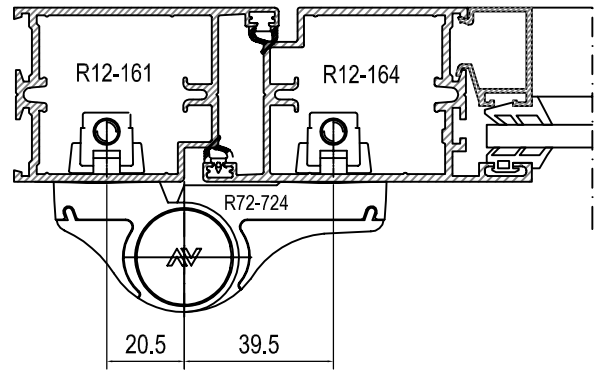
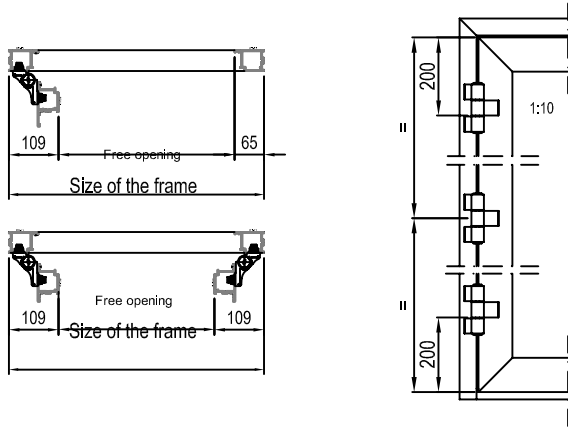

H	L																				
	900	1000	1050	1100	1150	1200	1250	1300	1400	1500	1600	1700	1800	1900	2000						
4000	•	•	•	•	•	•	•	•	•	•	•	•	•	•	•	•	•	•	•	•	
3900	•	•	•	•	•	•	•	•	•	•	•	•	•	•	•	•	•	•	•	•	5
3800	•	•	•	•	•	•	•	•	•	•	•	•	•	•	•	•	•	•	•	•	10
3700	•	•	•	•	•	•	•	•	•	•	•	•	•	•	•	•	•	•	•	•	5 15
3600	•	•	•	•	•	•	•	•	•	•	•	•	•	•	•	•	•	•	•	•	11 20
3500	•	•	•	•	•	•	•	•	•	•	•	•	•	•	•	•	•	•	•	•	6 16 25
3400	•	•	•	•	•	•	•	•	•	•	•	•	•	•	•	•	•	•	•	•	11 21 30
3300	•	•	•	•	•	•	•	•	•	•	•	•	•	•	•	•	•	•	•	•	6 17 26 35
3200	•	•	•	•	•	•	•	•	•	•	•	•	•	•	•	•	•	•	•	•	12 22 32 40
3100	•	•	•	•	•	•	•	•	•	•	•	•	•	•	•	•	•	•	•	•	6 18 28 37 45
3000	•	•	•	•	•	•	•	•	•	•	•	•	•	•	•	•	•	•	•	•	13 24 33 42 50
2900	•	•	•	•	•	•	•	•	•	•	•	•	•	•	•	•	•	•	•	•	7 19 29 39 47 55
2800	•	•	•	•	•	•	•	•	•	•	•	•	•	•	•	•	•	•	•	•	13 25 35 44 53 60
2700	•	•	•	•	•	•	•	•	•	•	•	•	•	•	•	•	•	•	•	•	7 20 31 41 50 58 65
2600	•	•	•	•	•	•	•	•	•	•	•	•	•	•	•	•	•	•	•	•	14 27 38 47 56 63 70
2500	•	•	•	•	•	•	•	•	•	•	•	•	•	•	•	•	•	•	•	•	8 21 33 44 53 61 68 X
2400	•	•	•	•	•	•	•	•	•	•	•	•	•	•	•	•	•	•	•	•	8 15 29 40 50 59 67 X X
2300	•	•	•	•	•	•	•	•	•	•	•	•	•	•	•	•	•	•	•	•	8 16 23 36 47 56 65 X X X
2200	•	•	•	•	•	•	•	•	•	•	•	•	•	•	•	•	•	•	•	•	9 17 24 31 43 53 63 X X X X
2100	•	•	•	•	•	•	•	•	•	•	•	•	•	•	•	•	•	•	•	•	9 17 25 32 38 50 60 69 X X X X
2000	•	•	•	•	•	•	•	•	•	•	•	•	•	•	•	•	•	•	•	•	10 18 26 33 40 46 57 67 X X X X X

Table 1

X= Not useful
 17 (or other number)= percentage which increases your sash weight
 H= Door leaf height
 L= Door leaf width

First calculate the leaf weight. Then check if you need an additional weight adding with a table 1 percentages. With the final weight you can define the suitable hinges using the table 2. Door closers increases thr loads on the hinges and their wear. Wind-breaking door closers are loading the hinges more. In this case the total door sash's weight must be increased on 75%. If there is no wind-break in a door closer - weight must be increased on 20 %.

Table 2

Hinge	2 parts	3 parts
R72-724-2 R72-724-3	160 kg	180 kg
R72-722 R72-723	120 kg	140 kg

height of the door leaf > 2,1m-- 3 hinges

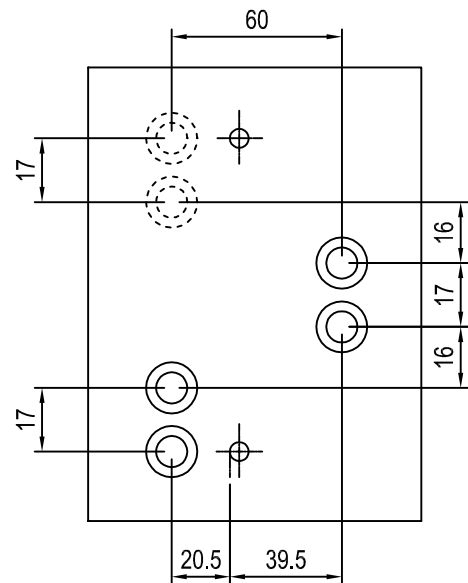

Drill jigs are available

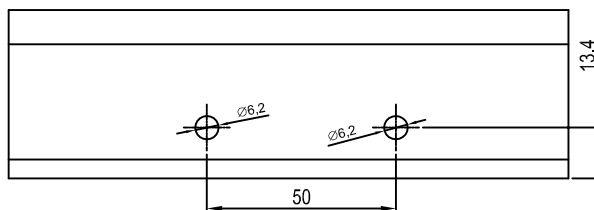
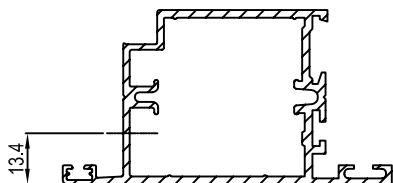
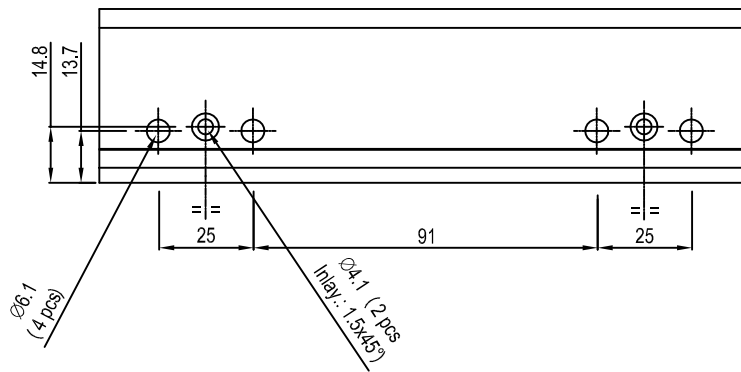
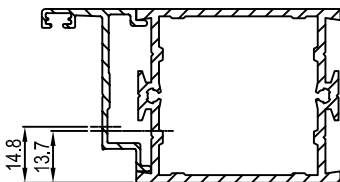
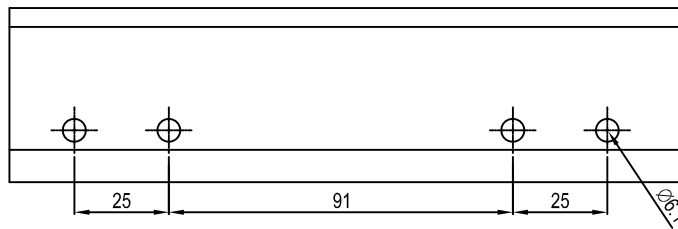
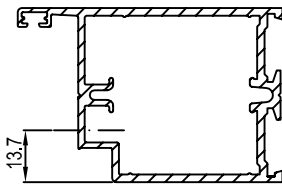
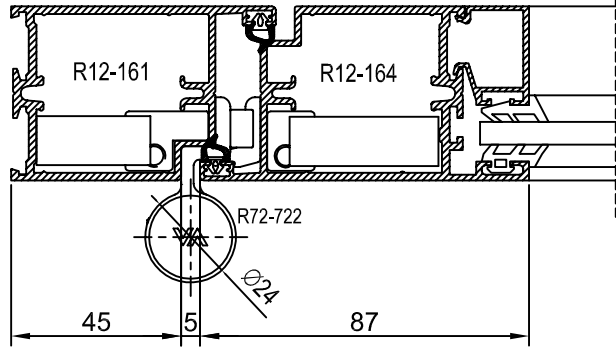
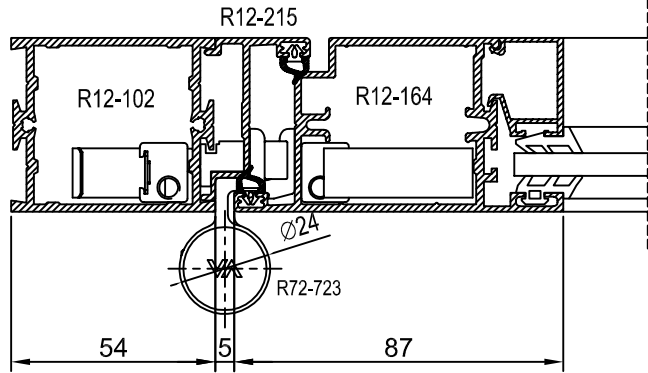
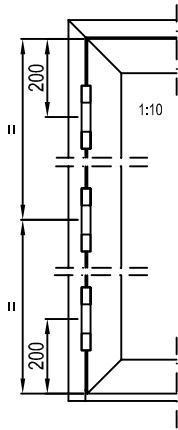
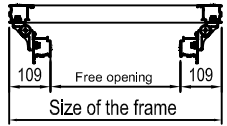
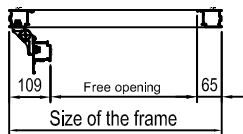

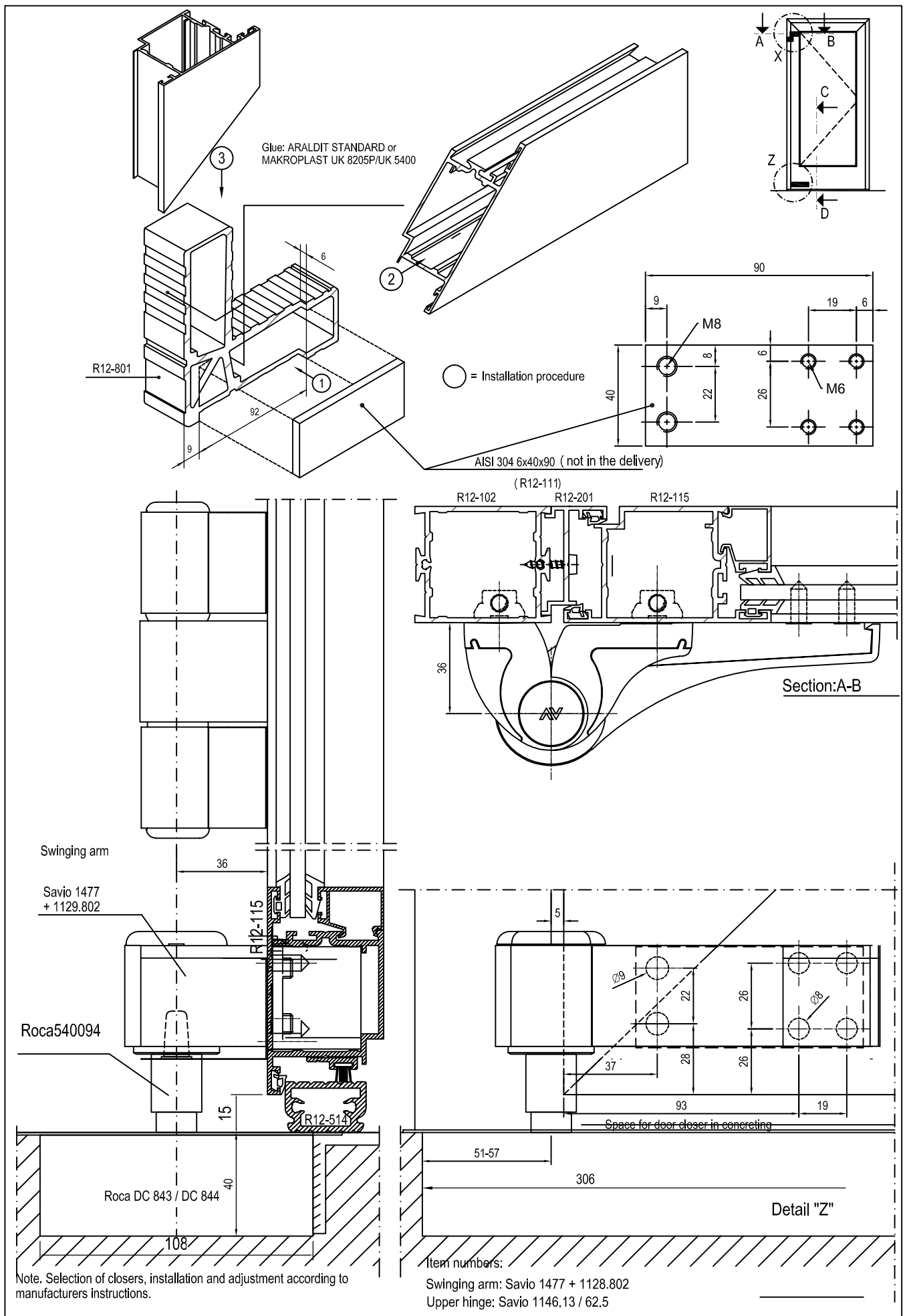

01.07.2013

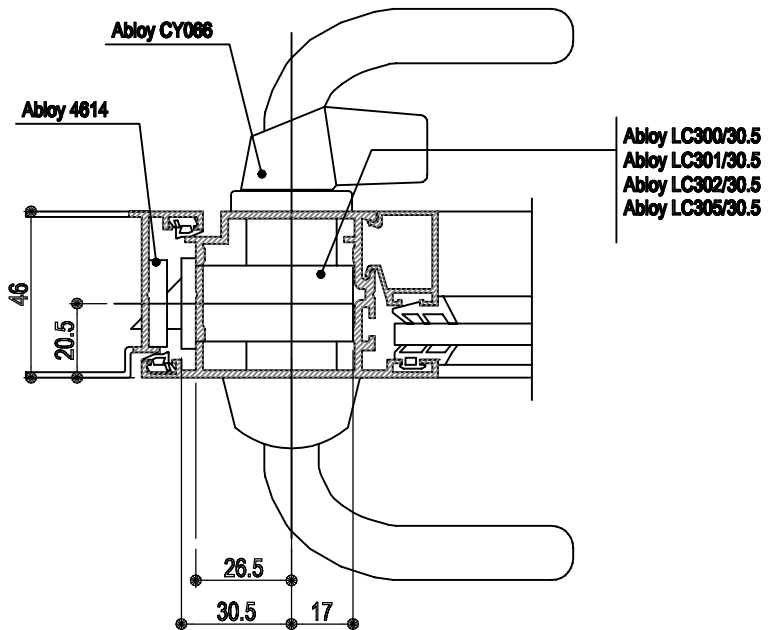
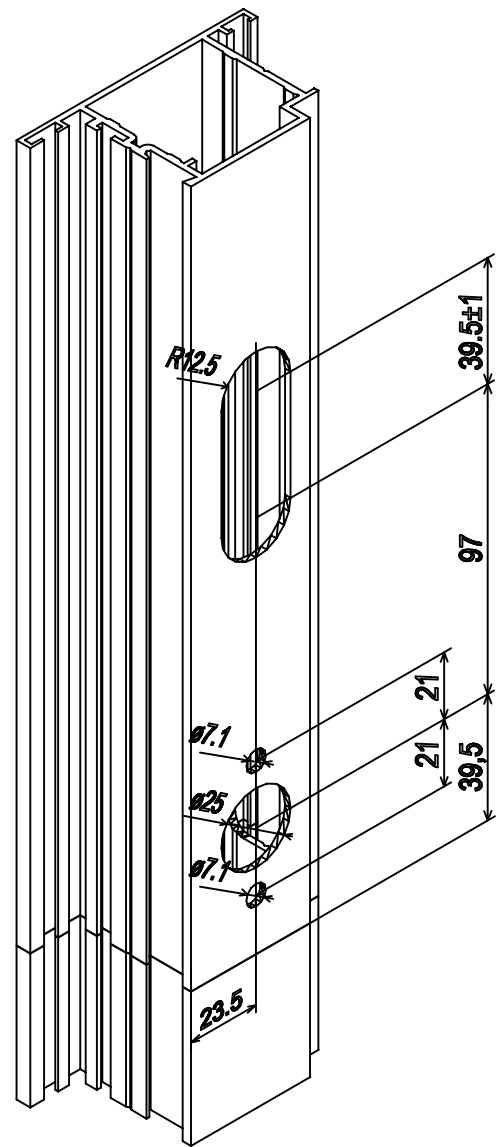
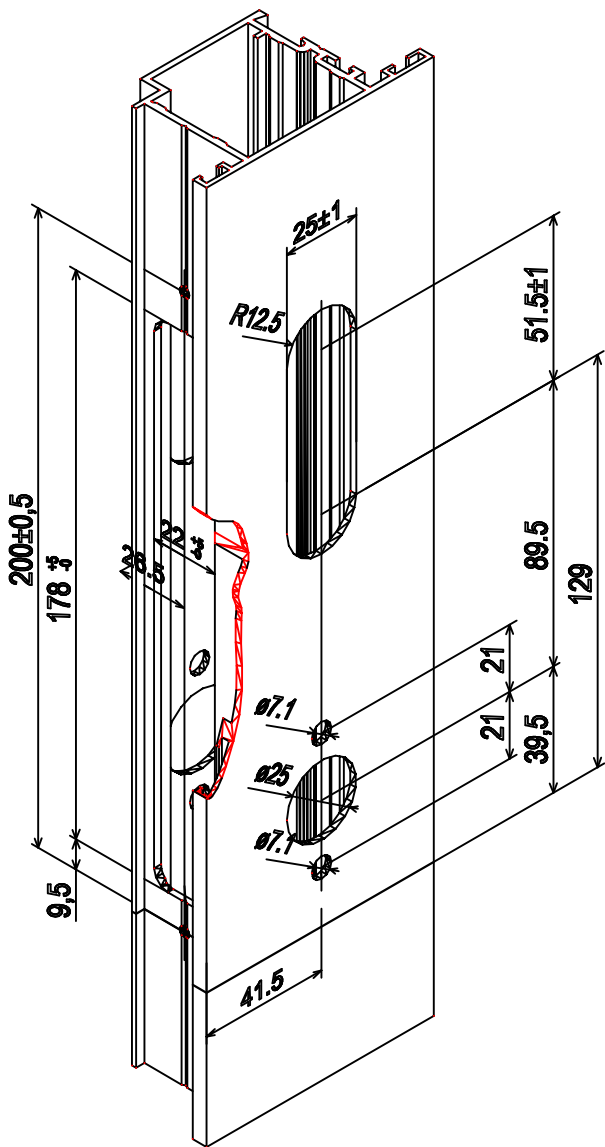

01.07.2013

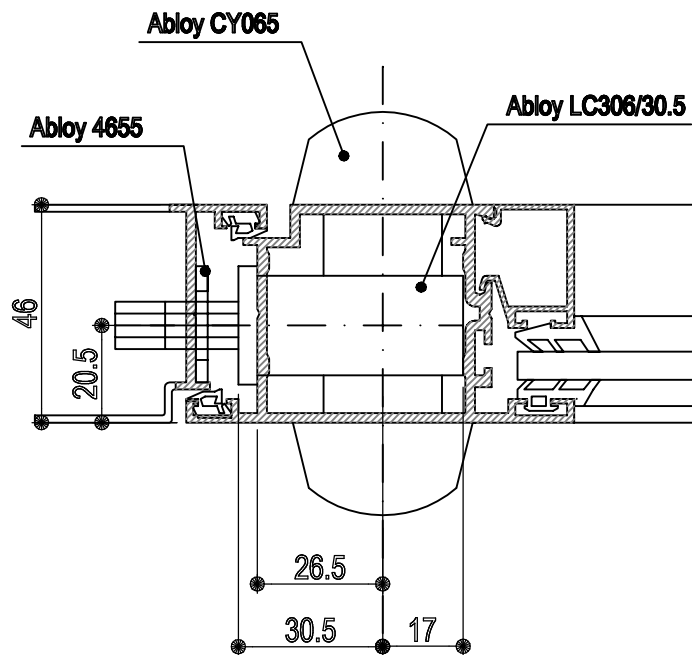
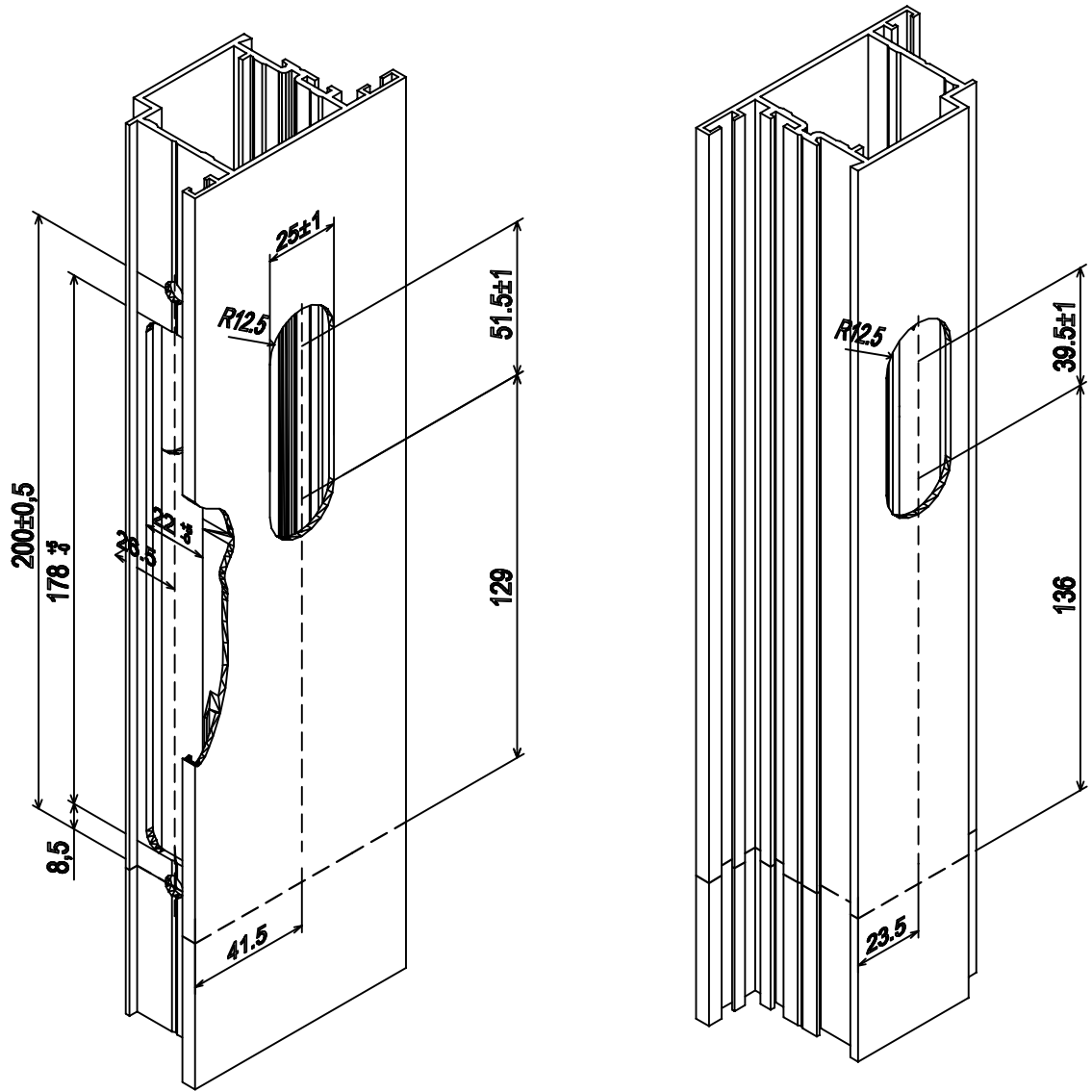

Pikasalpa R12-727

Machinings

R12	19
-----	----

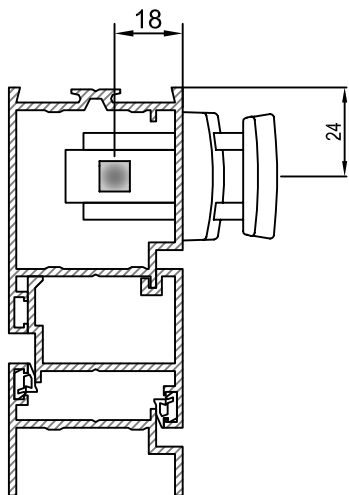
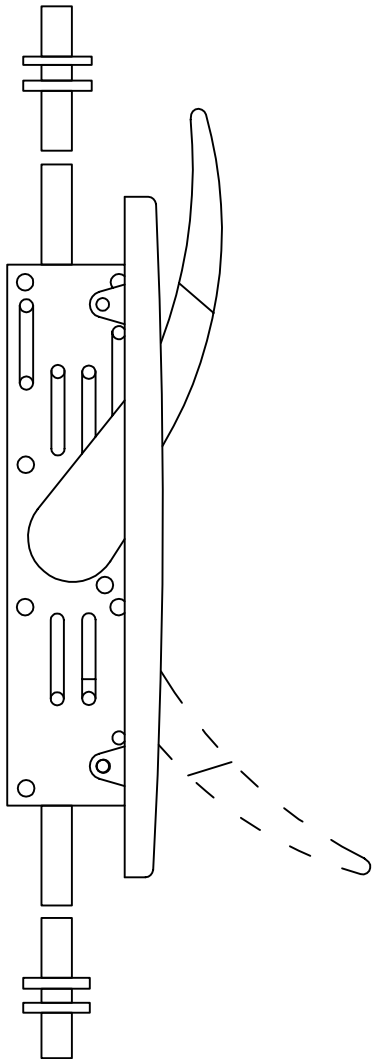

Pariovensalpa R72-728

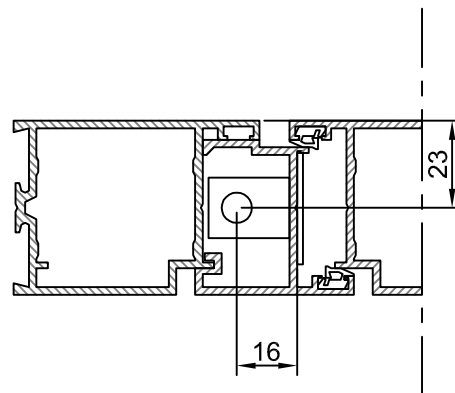
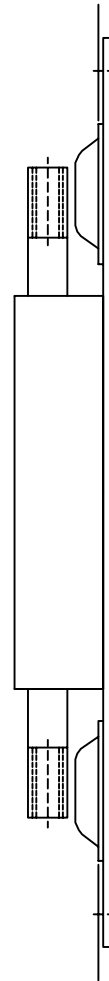

01.07.2013

R12

18

NOKIAN
PROFILES



Dead bolts

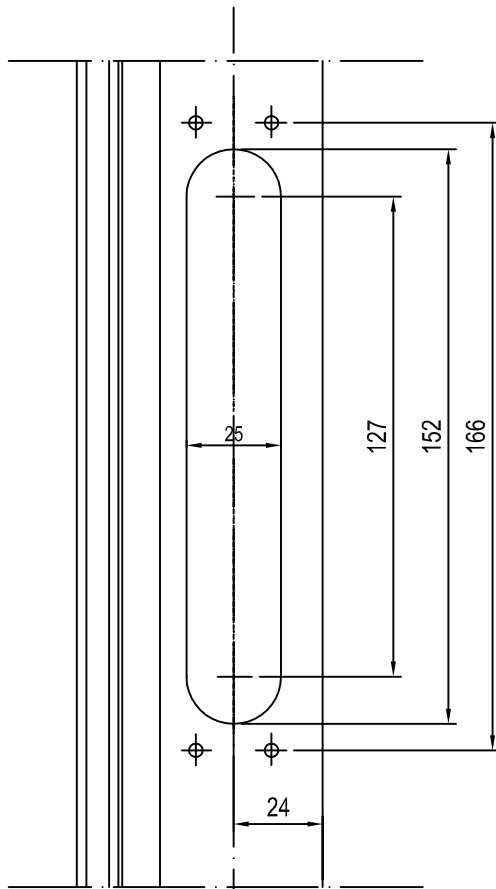
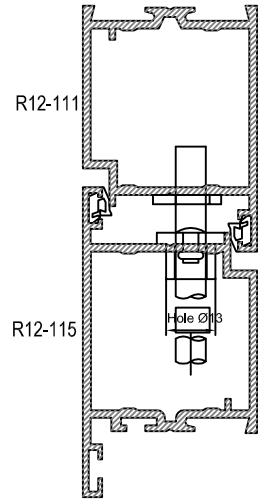
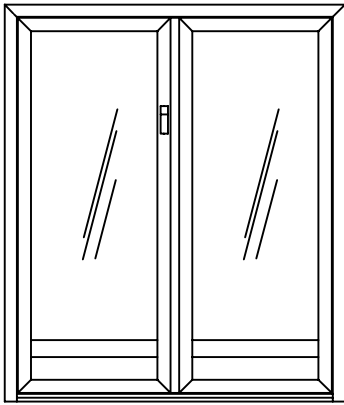

Connection rivet Ø4x12

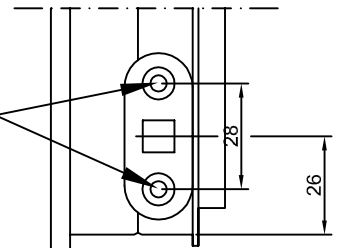

Trackpad

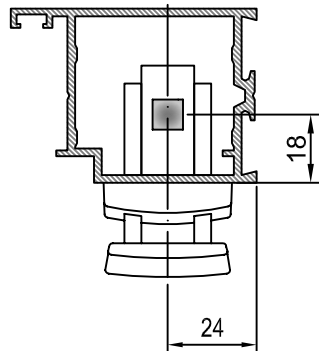
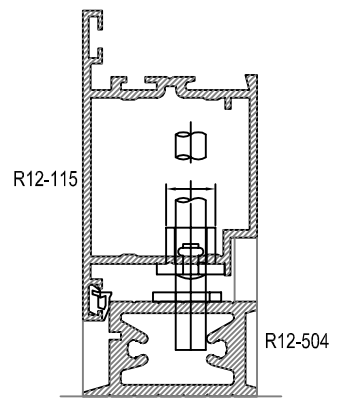

Connection rivet Ø4x12

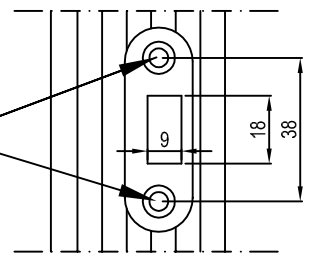

Counterplate

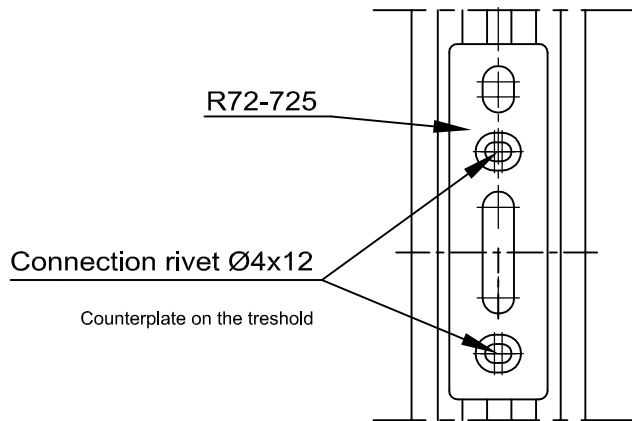
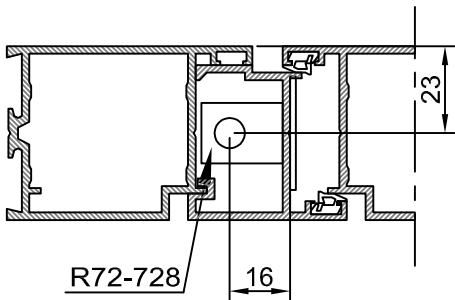
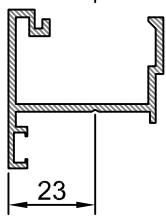
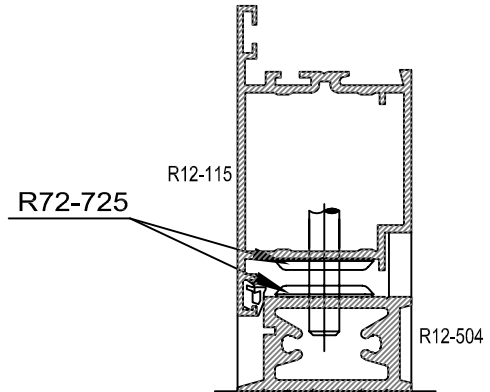
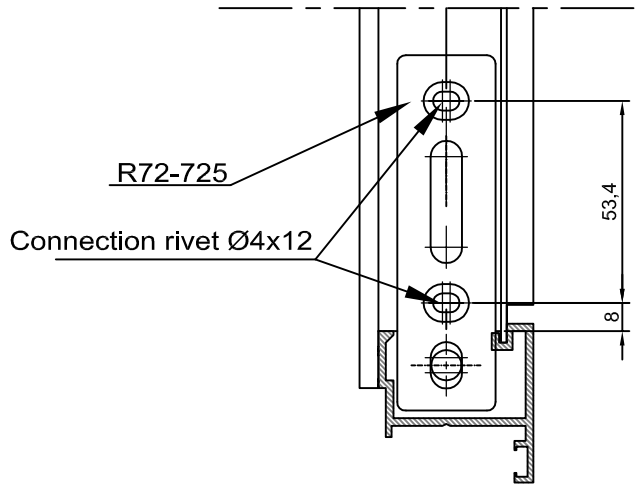
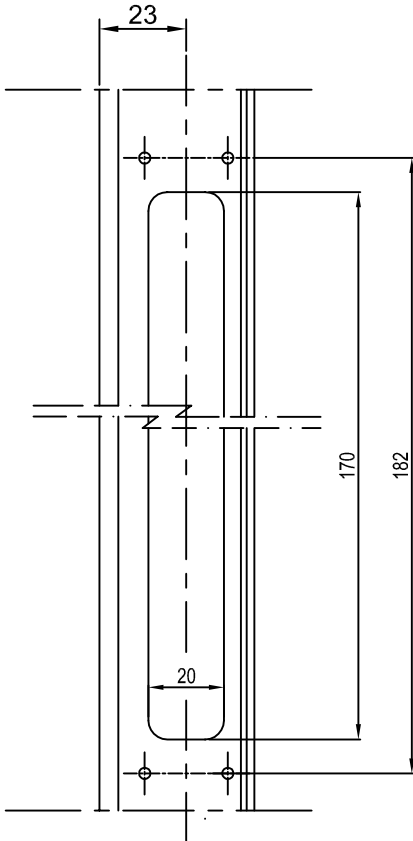
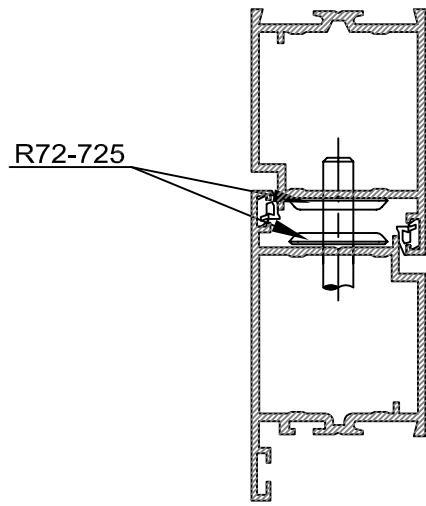
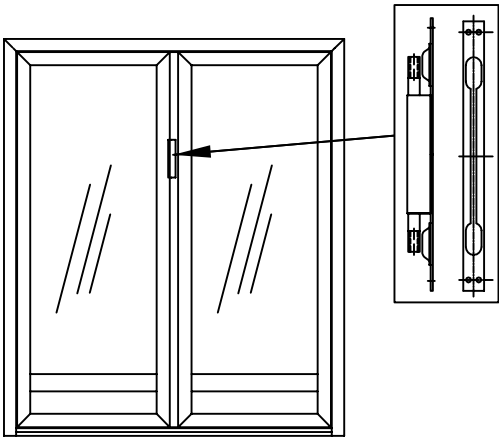

01.07.2013

Cross-section C - D

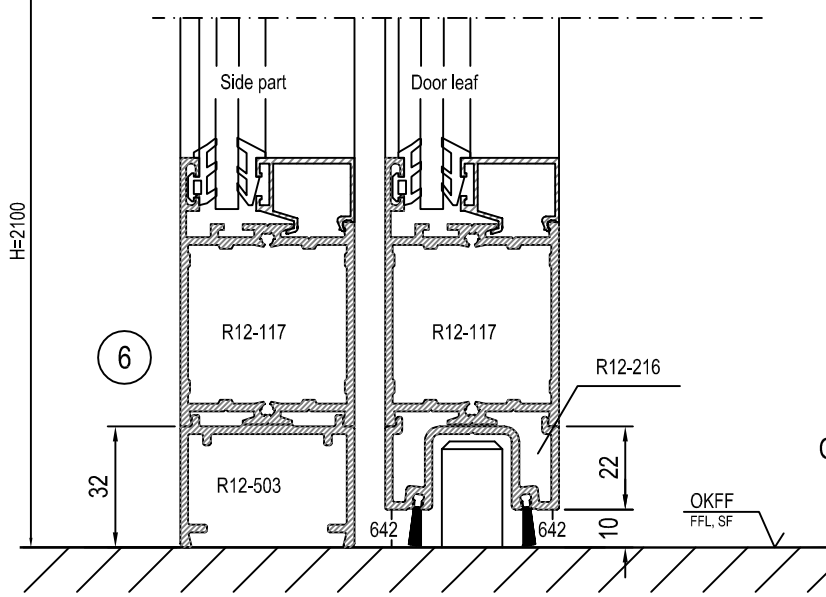
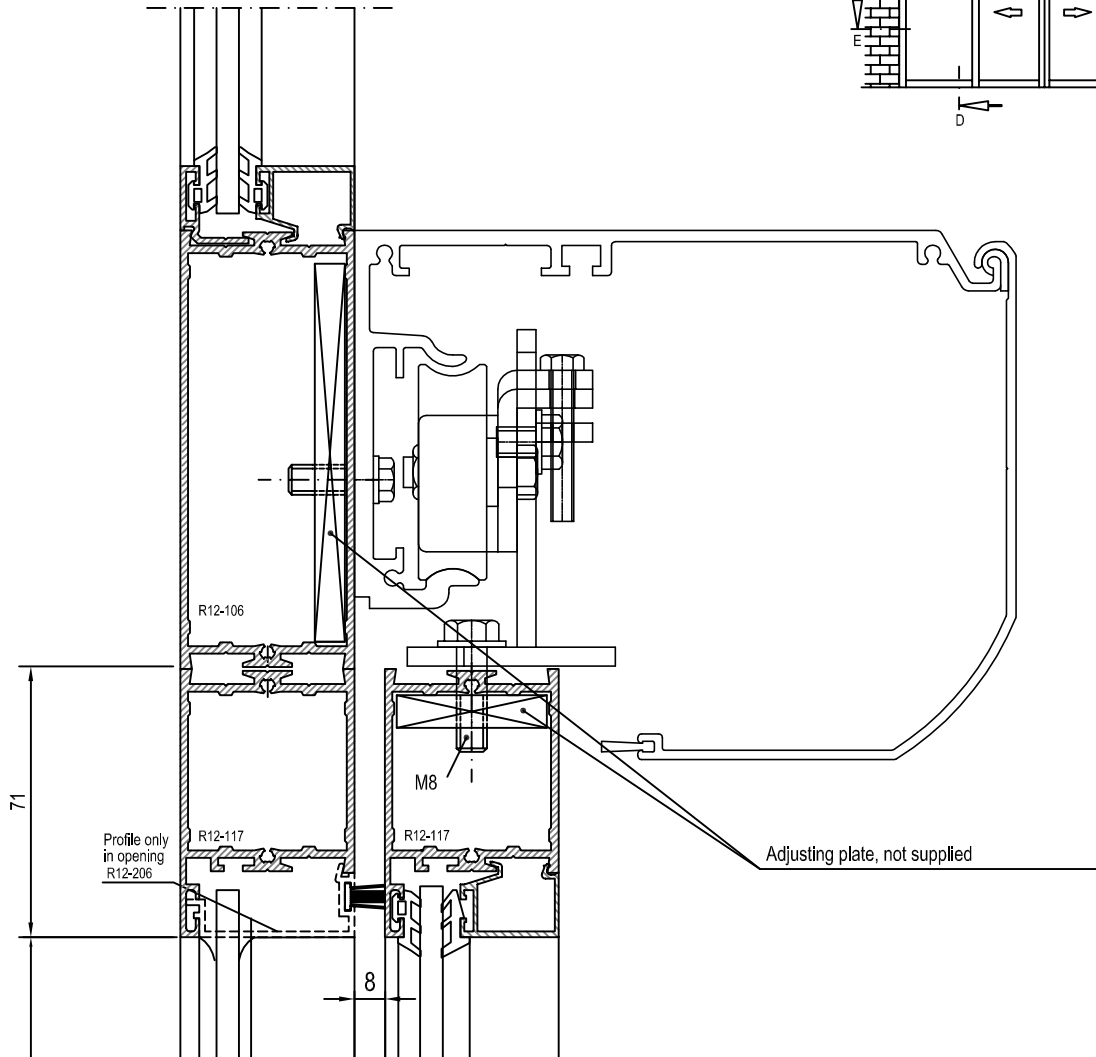
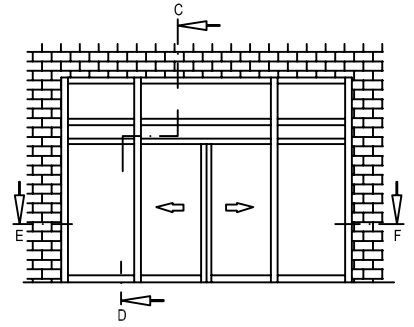

Cross-section E-F check drawing: R12-22

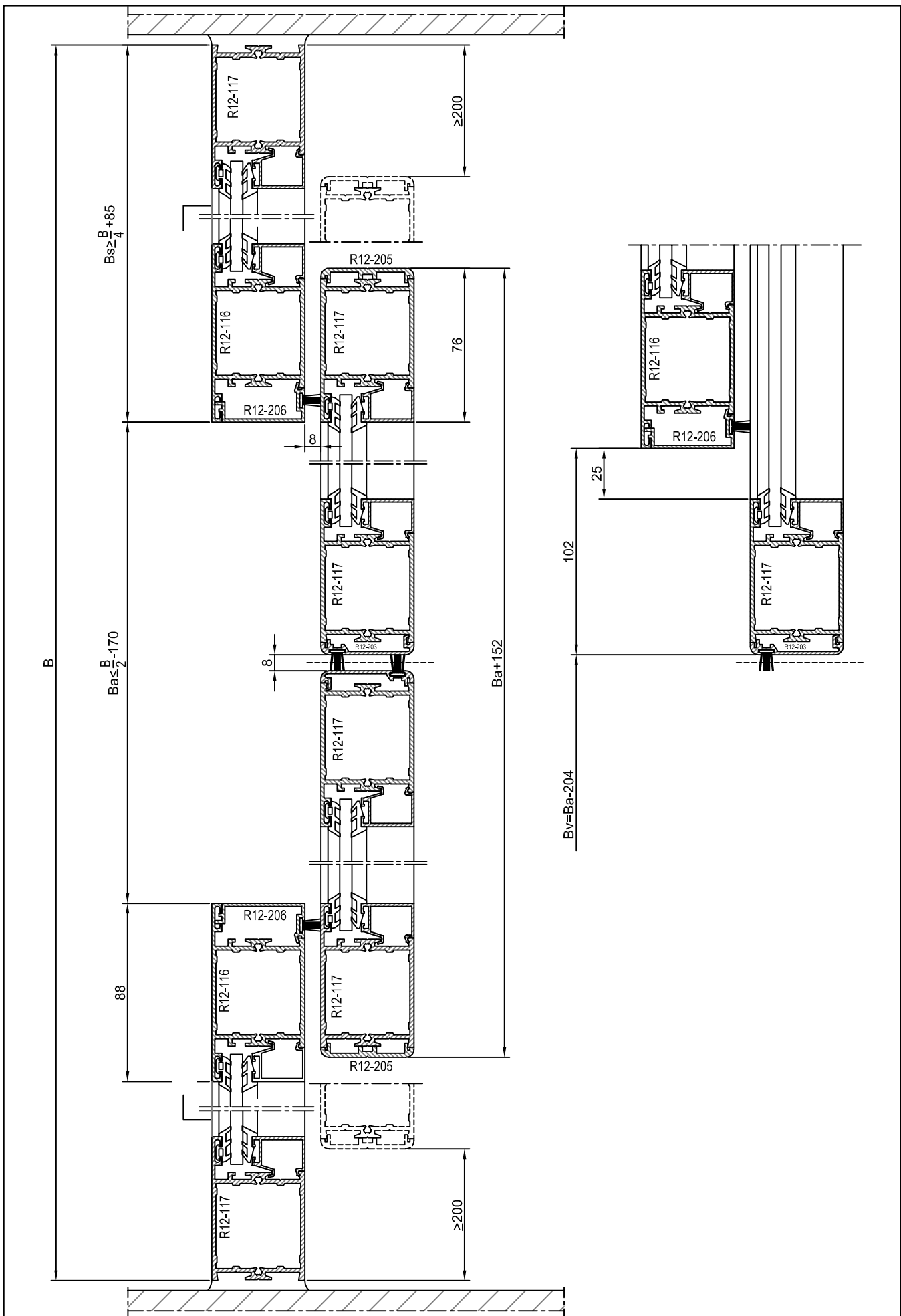

01.07.2013

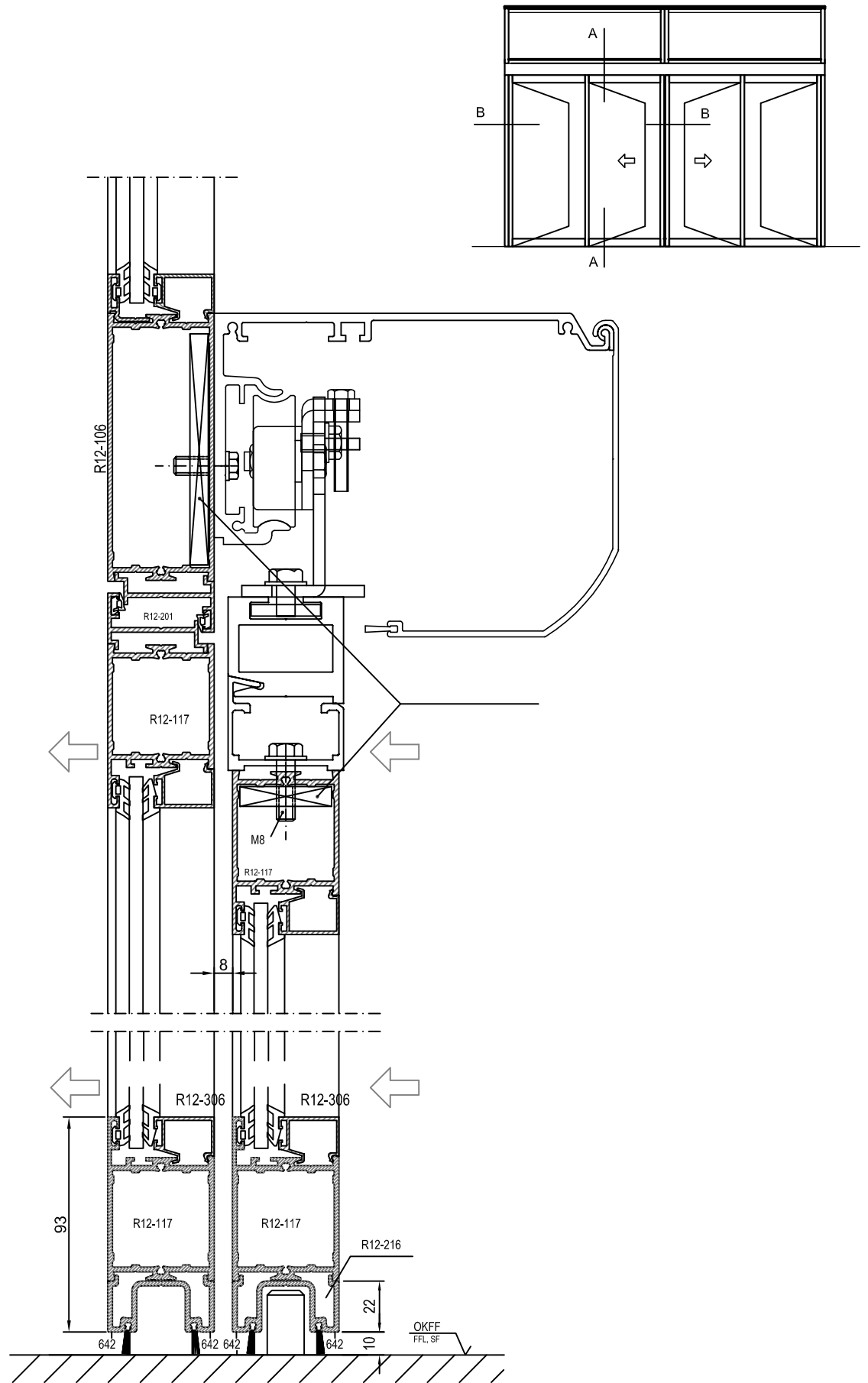

01.07.2013

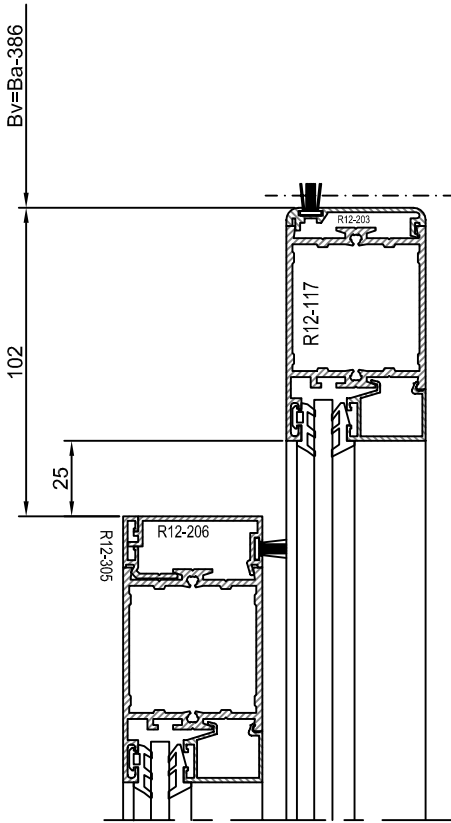
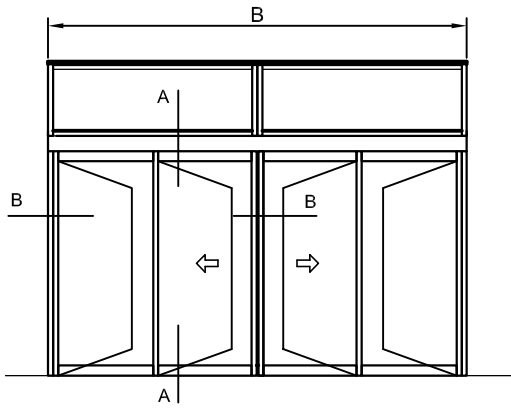

$$B_s \leq \frac{B}{2} - 182$$

$$B_s \geq \frac{B}{4} + 91$$

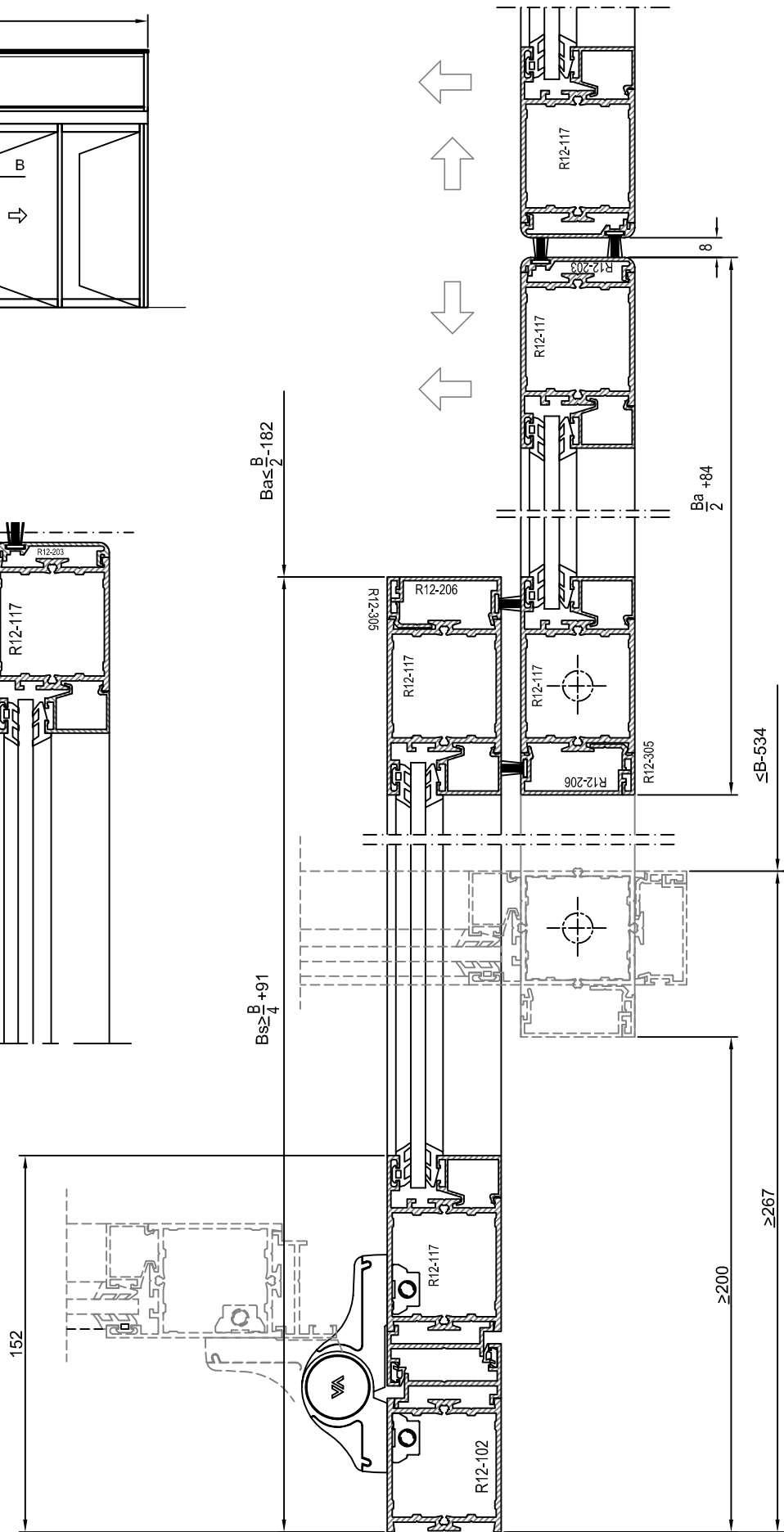

01.07.2013

R12

24

NOKIAN
PROFILES

Automatic sliding door with panic release

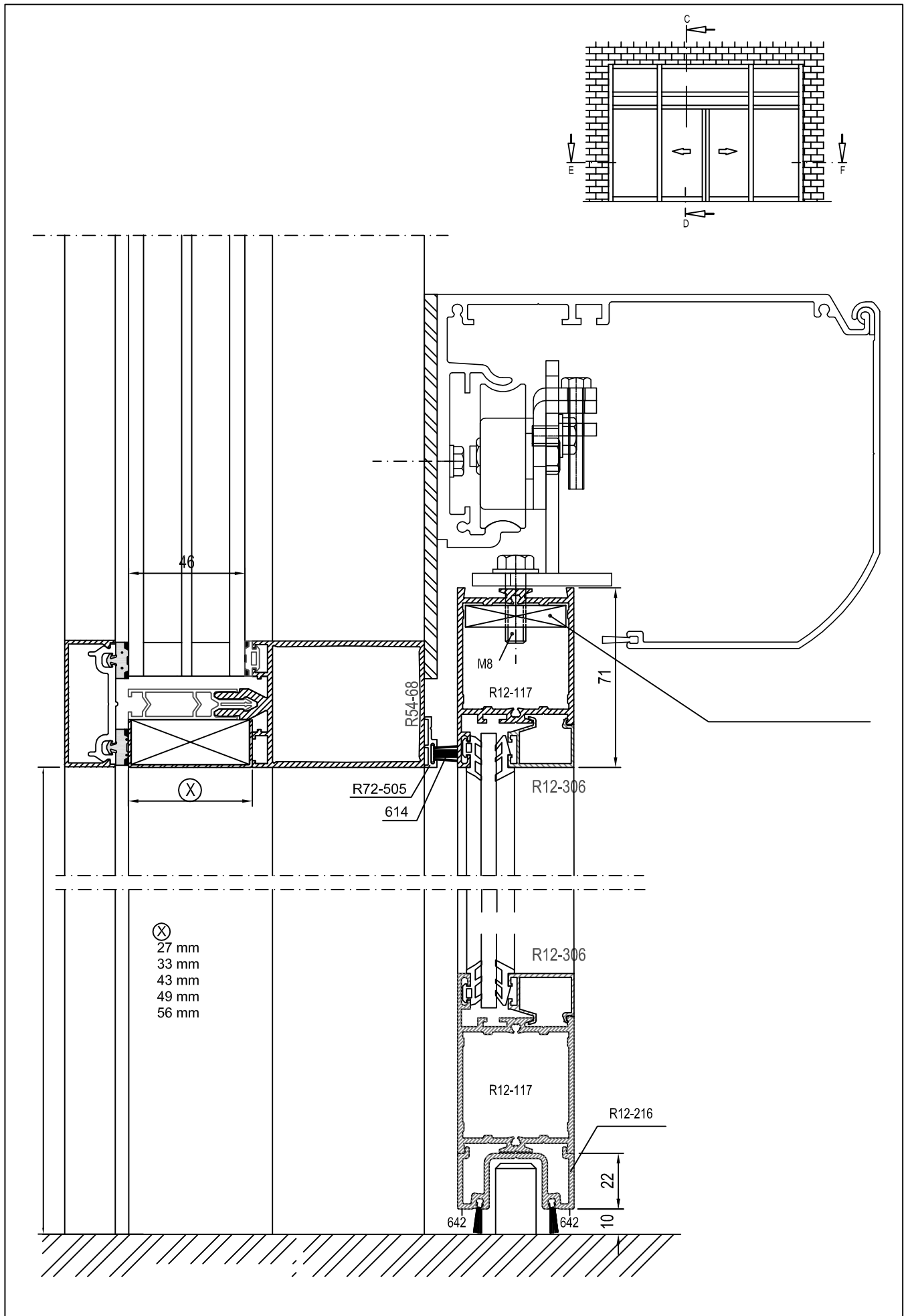

01.07.2013

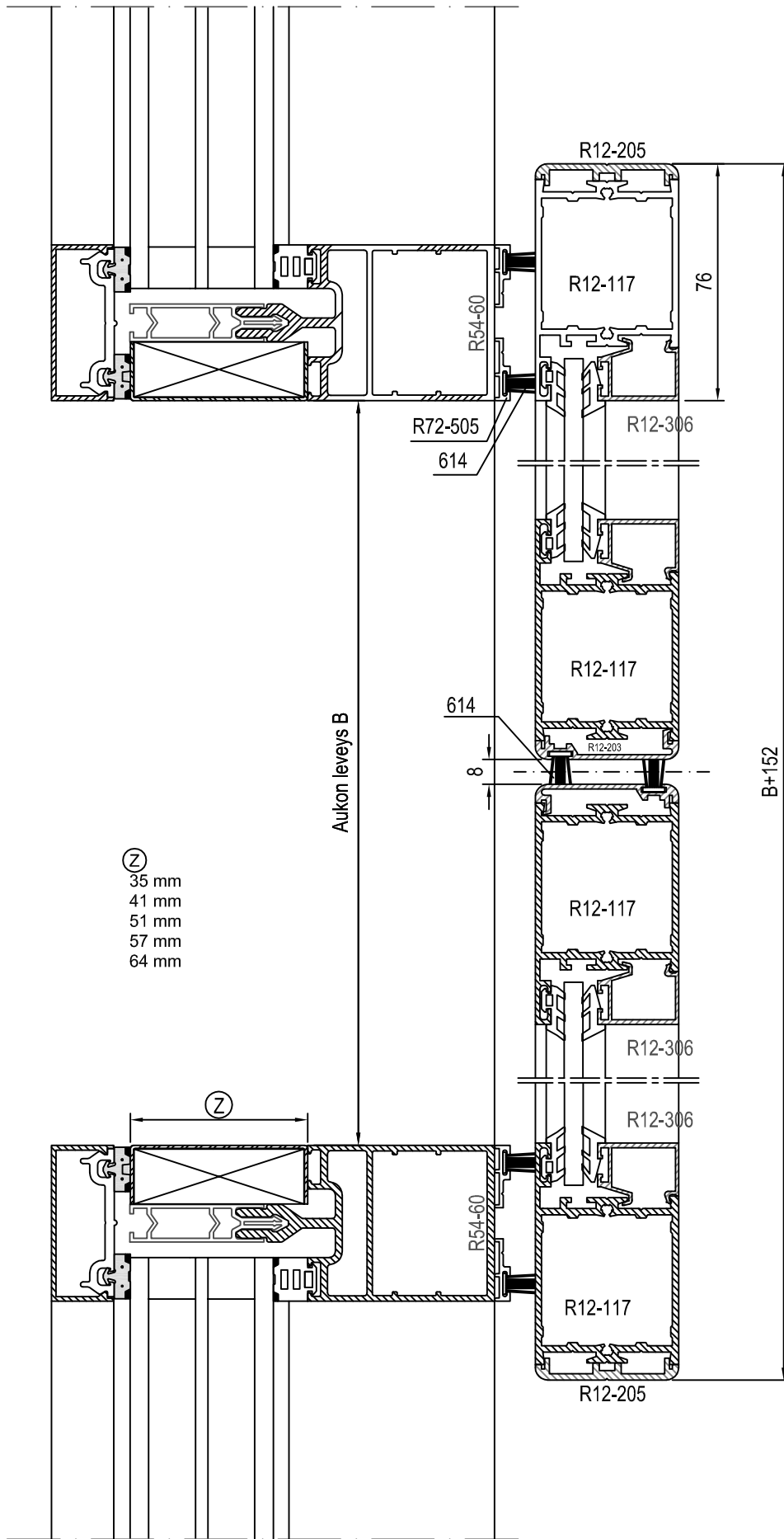

01.07.2013

R12

26

NOKIAN
PROFILES



Automatic sliding door

Screw fastening angle joint

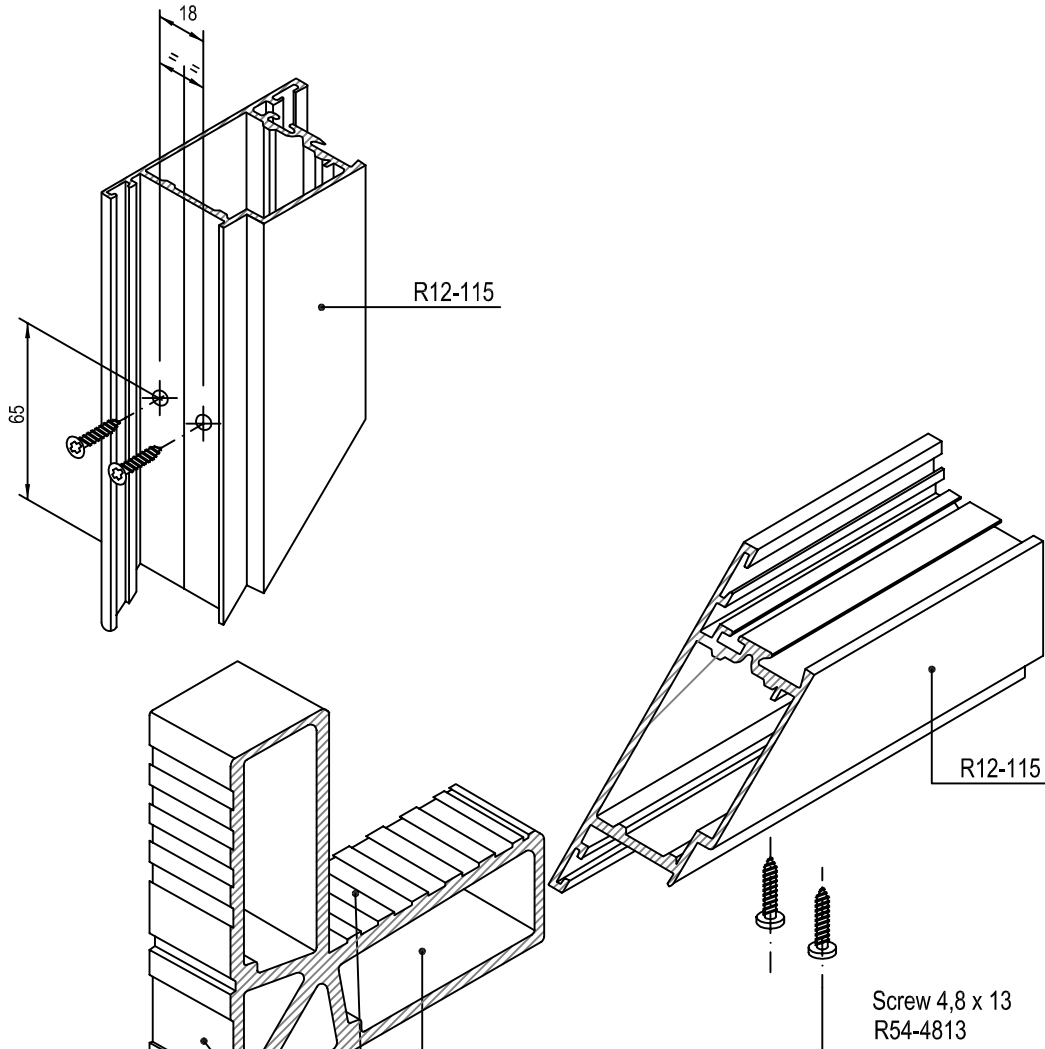

Glue:ARALDIT STANDARD or
MAKROPLAST UK8205P/UK5400

R12-801	(40.5x35 mm)
for profiles	R12-111 R12-112 R12-115
R12-802	(40.5x40.5 mm)
for profiles	R12-102 R12-103 R12-116 R12-117

Glue pressing angle joint

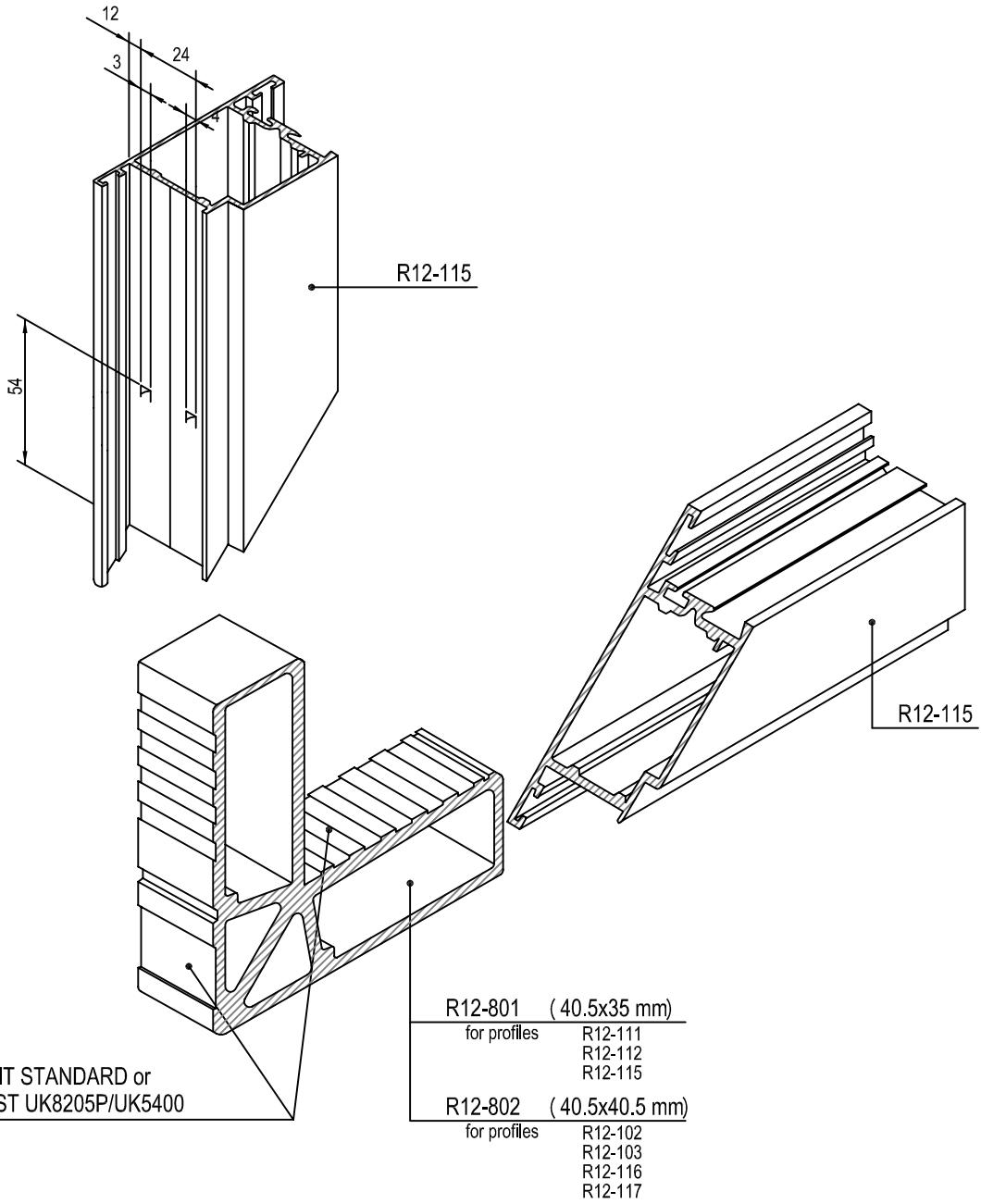

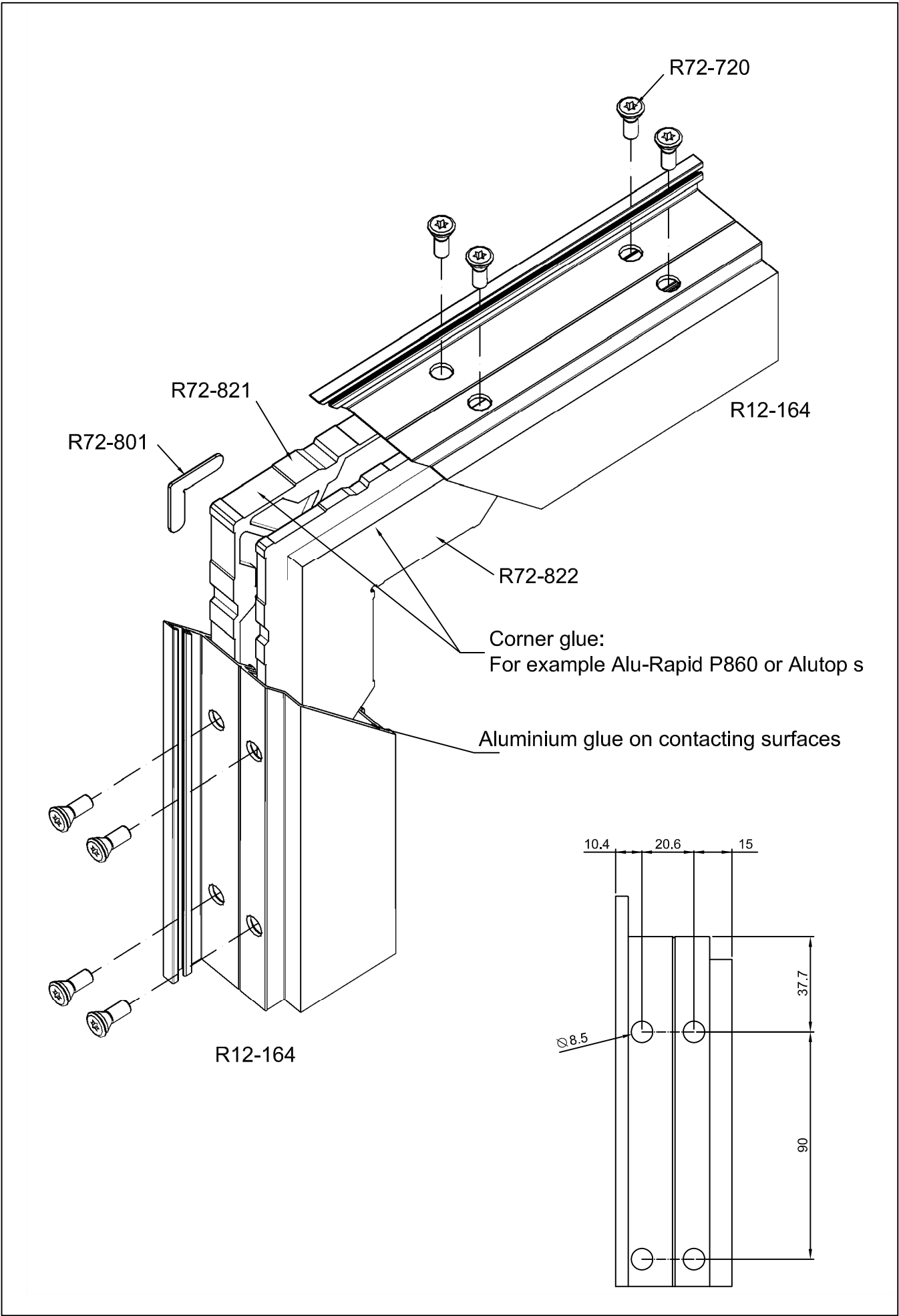

01.07.2013

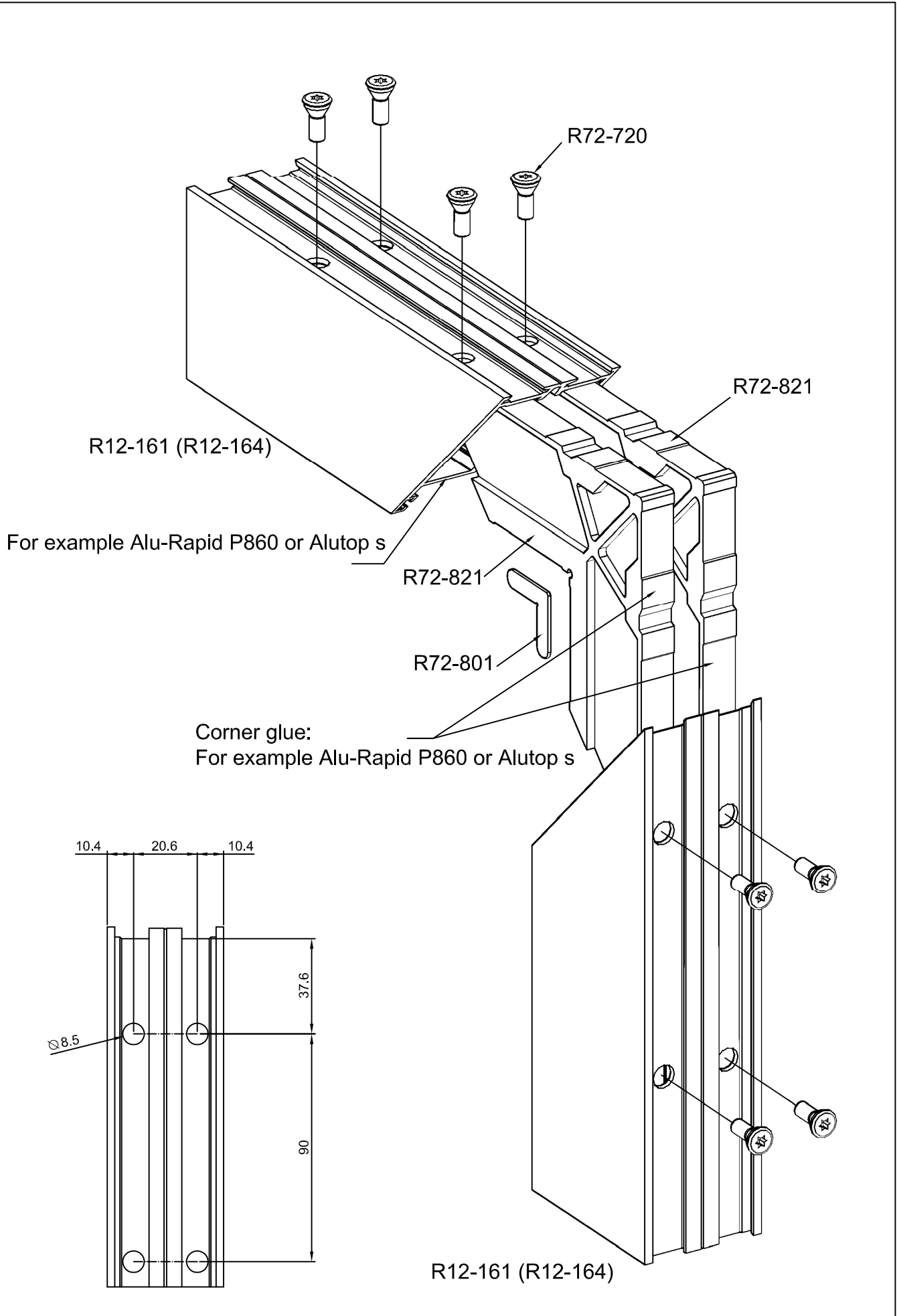

01.07.2013

R12

30

NOKIAN
PROFILES

R12-161 (R12-164) mitre joint

Step 1

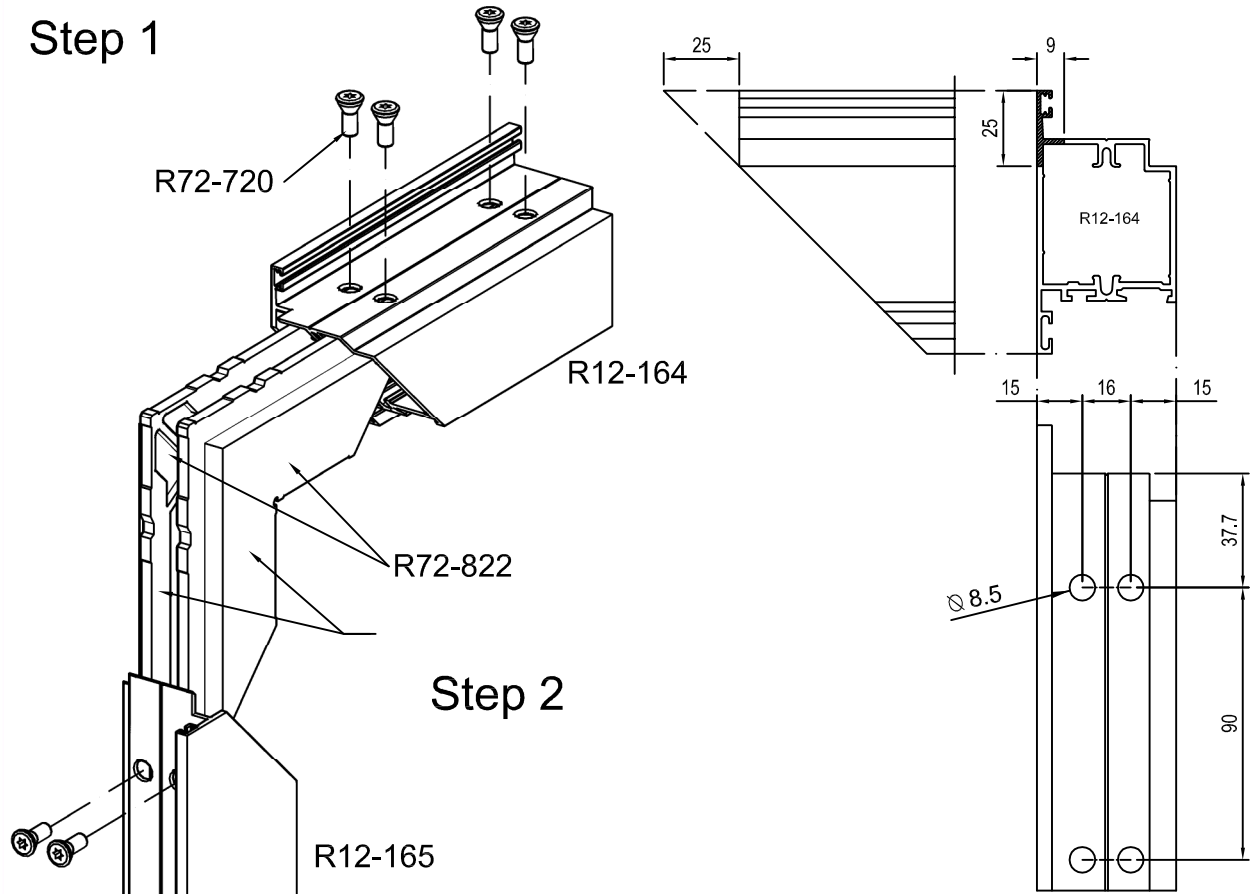

Step 2

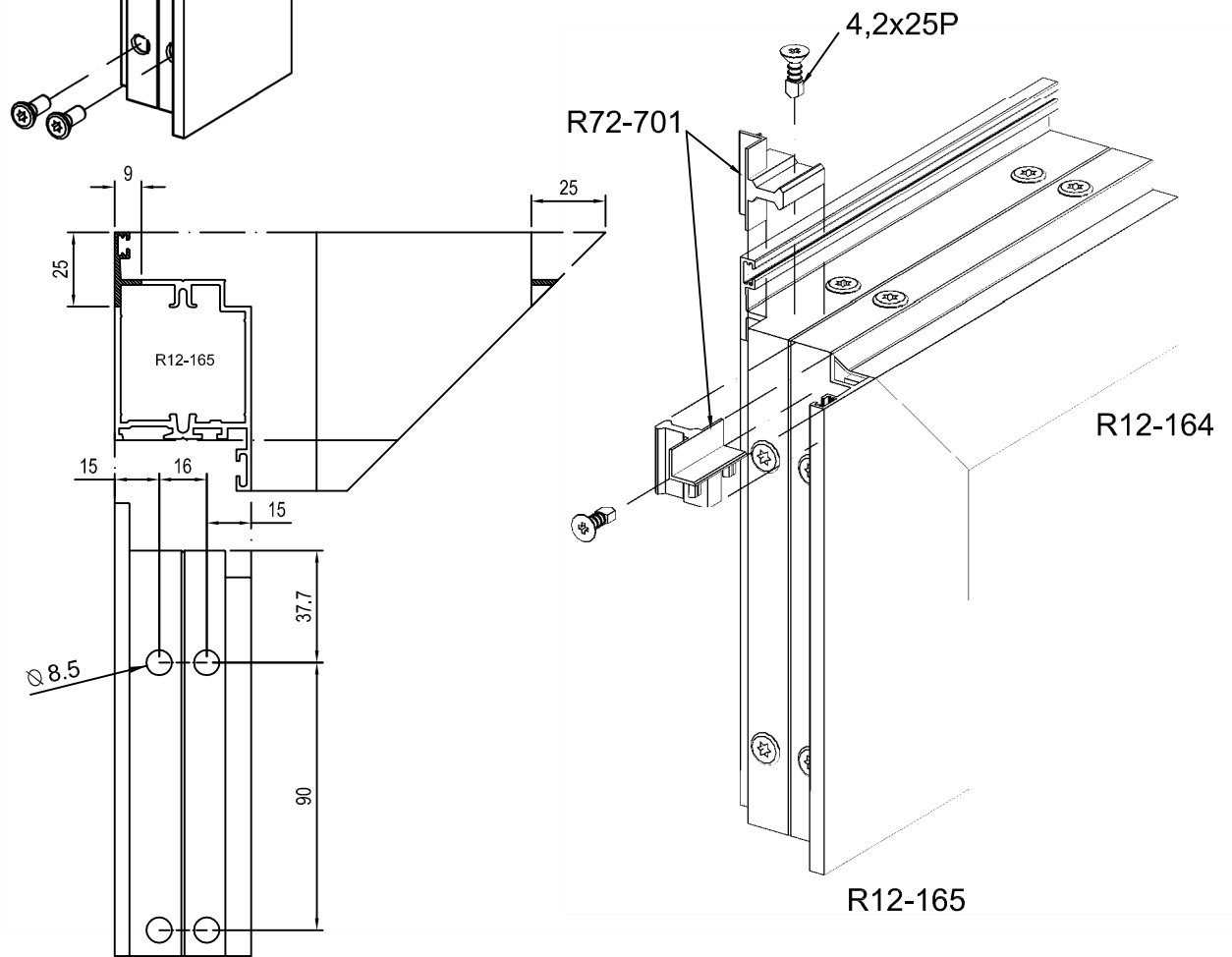

01.07.2013

R12-113 T joint

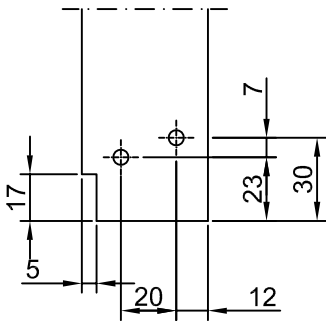
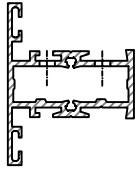

Glue: ARALDIT STANDARD or
MAKROPLAST UK8205P/UK5400

Tapping screw 4,8x16 DIN 7504 P A2
(R72-4816PU)

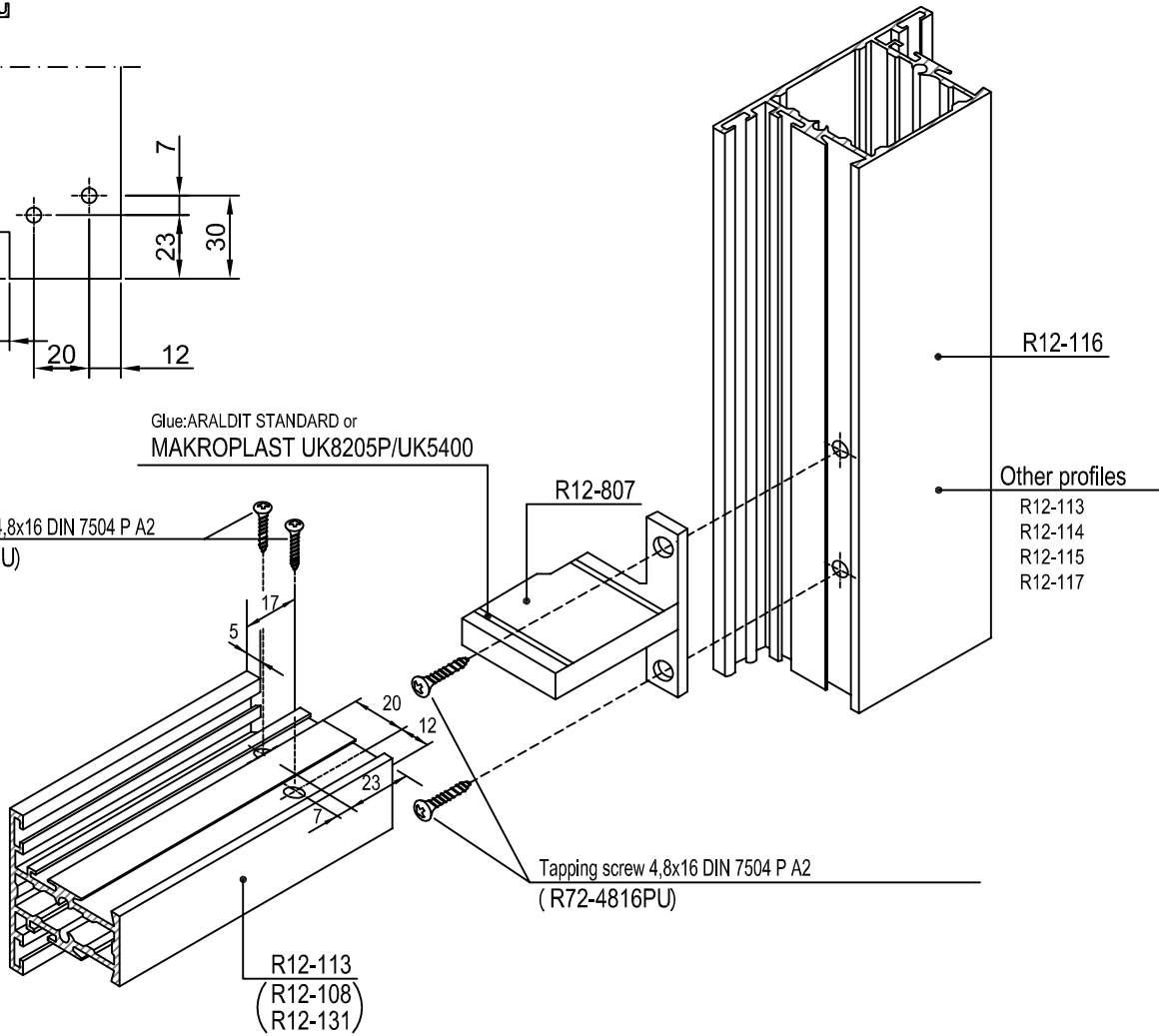

Tapping screw 4,8x16 DIN 7504 P A2
(R72-4816PU)

R12-113
(R12-108)
(R12-131)

R12-116

Other profiles

- R12-113
- R12-114
- R12-115
- R12-117

R12-116 T joint

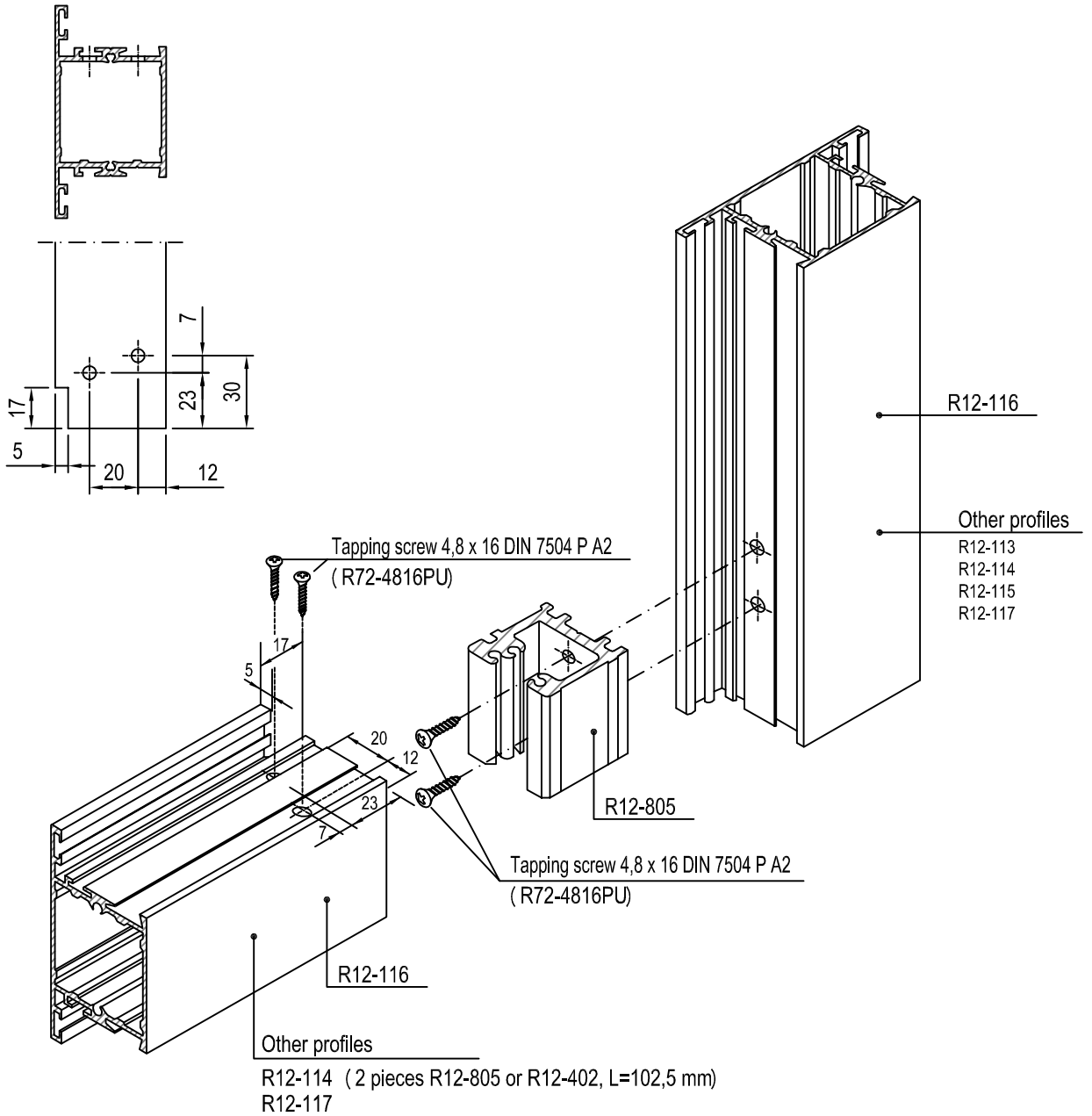

01.07.2013

R12-108 T joint

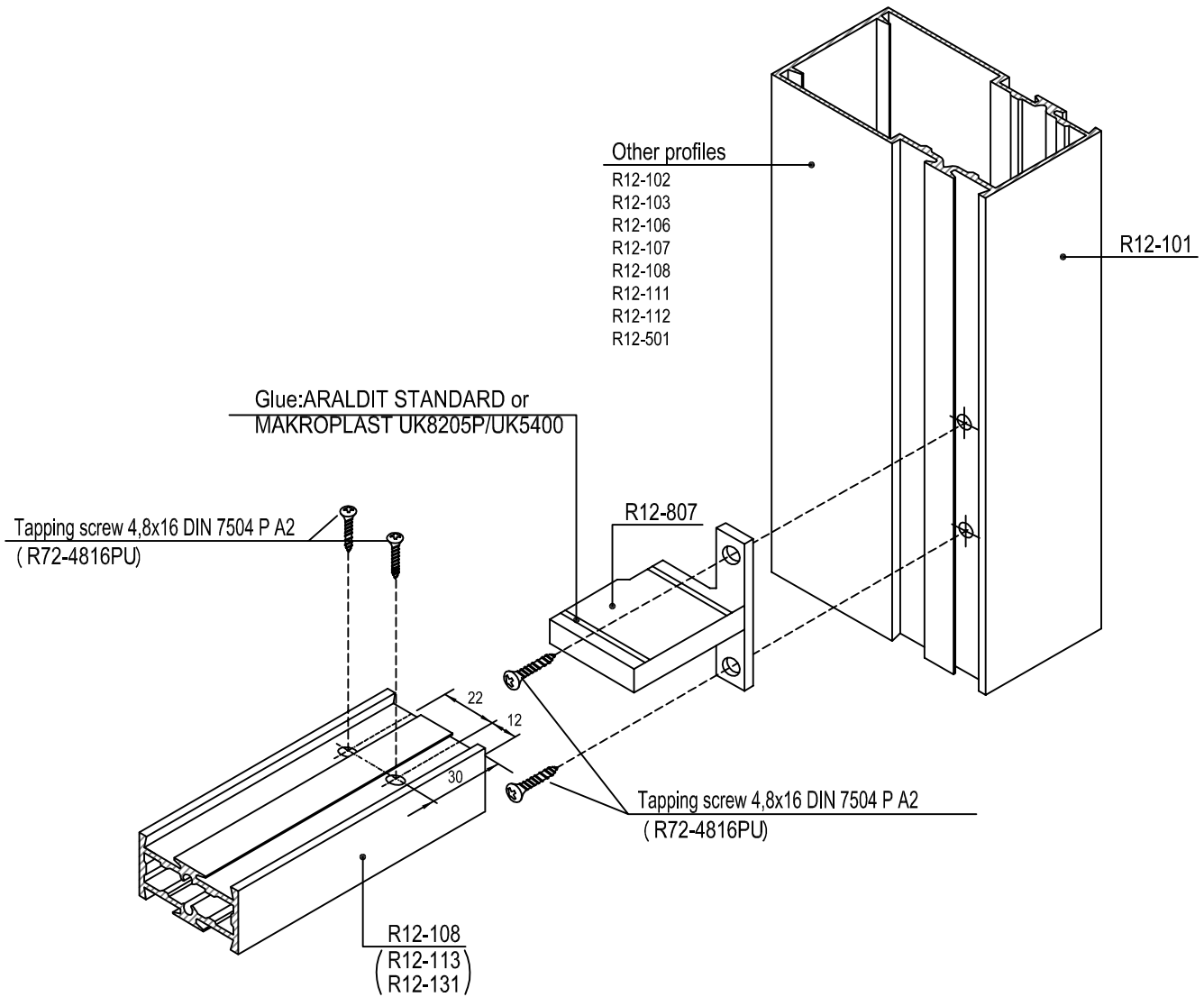

01.07.2013

R12

34

NOKIAN
PROFILES

T joints to R12-101 (and similar)

R12-102 T joint

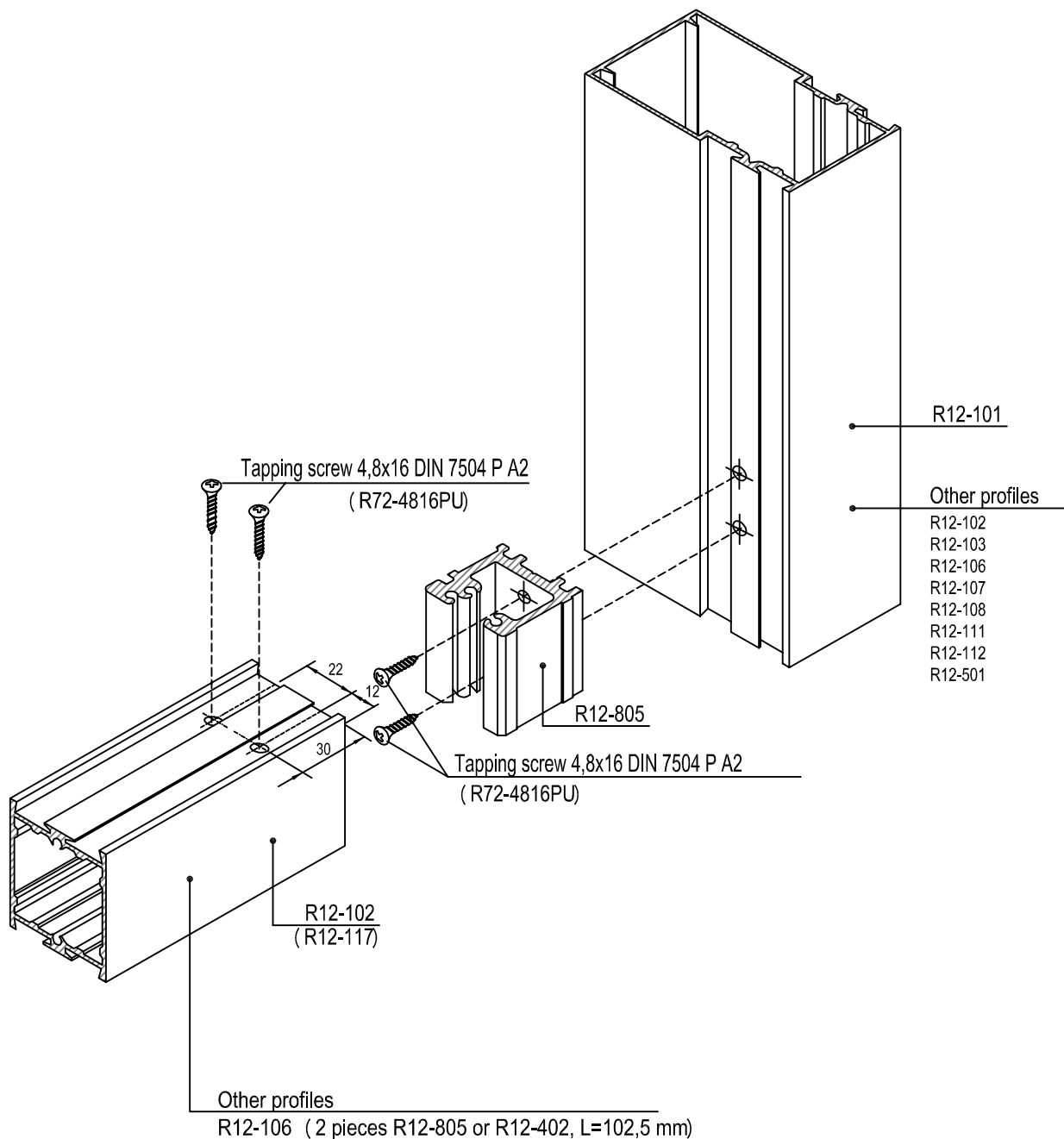

01.07.2013

T joints with R12-102
to R12-101 (and similar)



R12

35

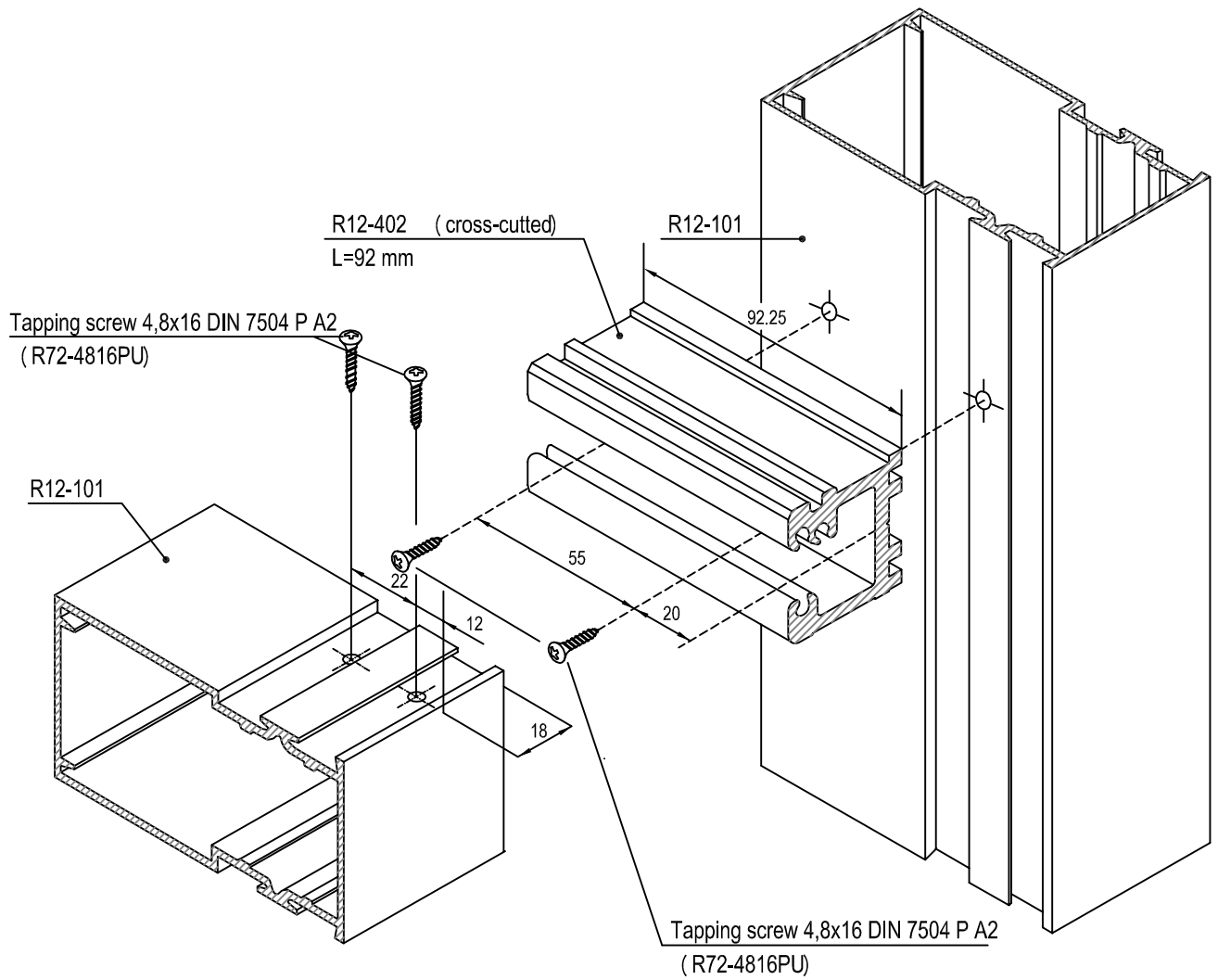

01.07.2013

R12

36

NOKIAN
PROFILES



R12-101 T-joint

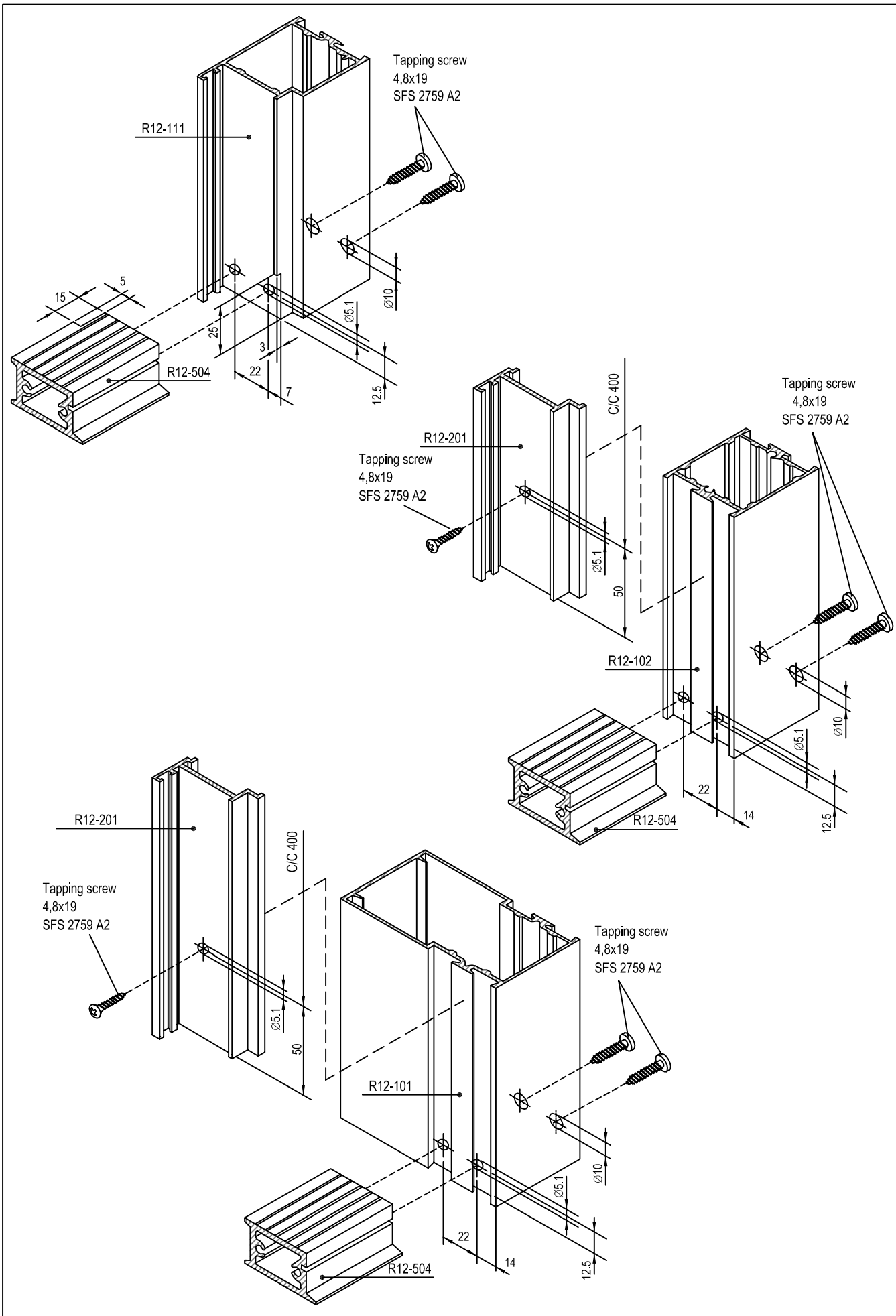

01.07.2013

Jointing of R12-504 threshold and profiles R12-111, -102 and R12-101



R12

37

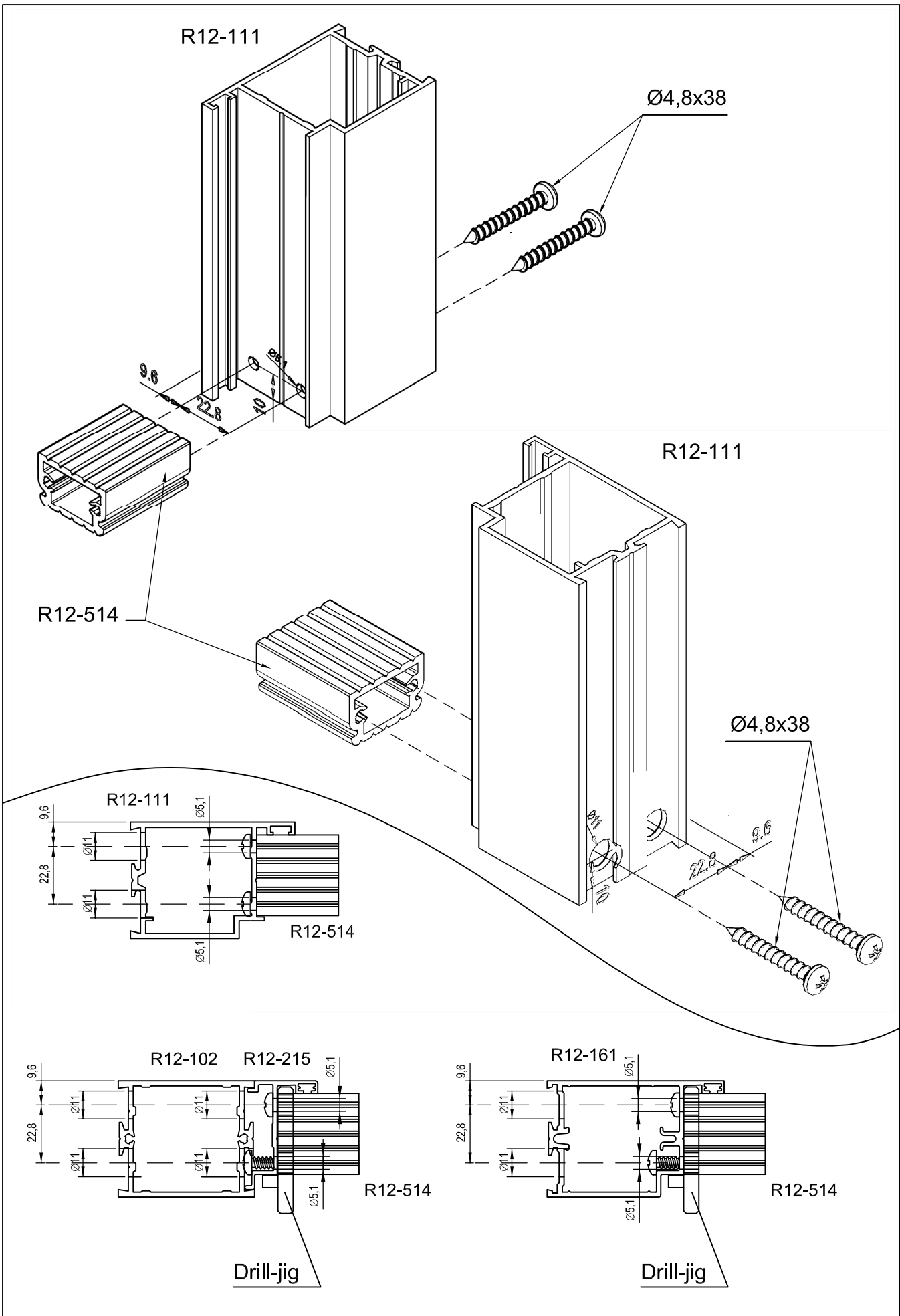

01.07.2013

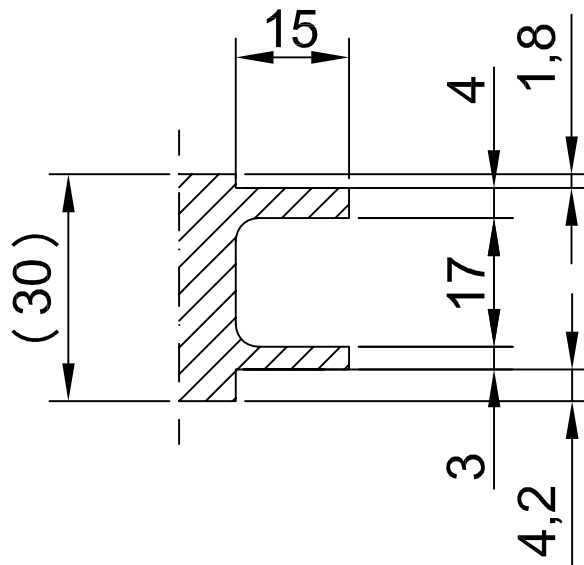
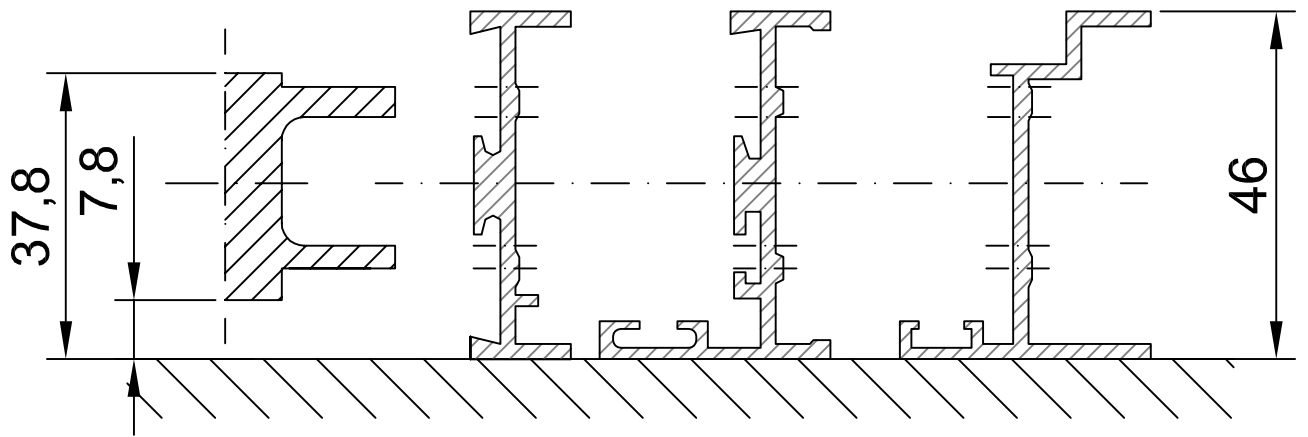

Choice of glazing beads in connection with sealings 611 + 612

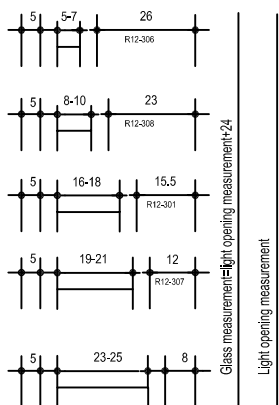

Choice of glazing beads in connection with sealings 619 + 612

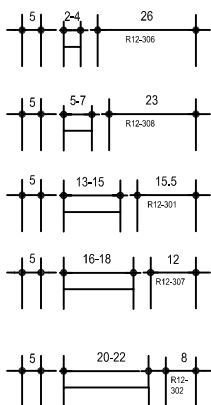

Placement of pads:

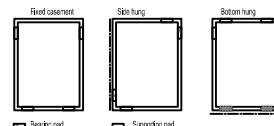

Choice of glazing beads in connection with sealings 611, 630 + 612

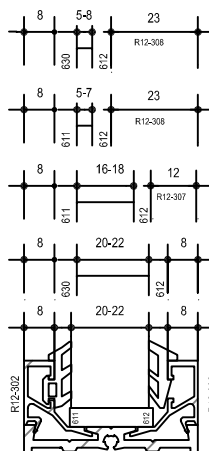

choice of glazing beads in connection with sealings 611, 630 + 612

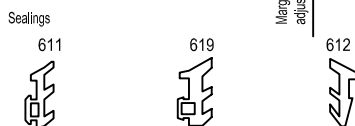
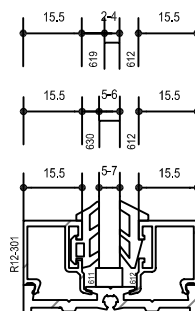

Vacuum glass pad 100x29x5
Rolled glass pad 100x10x5

Glazing

When starting the glazing, make sure that the rabbets, glazing beads and glass is clean. Then fit the exterior glazing sealing no. 611, 619 or 630 into the profile groove.

After installing the glass and glazing beads, glazing sealing no. 612 is installed into place. Asilicon spray or other suitable lubricant can be used to facilitate the installation of sealing no. 612.

When cutting the glazing sealing, a shrinkage allowance of 0,5% must be observed.

On exterior structures, glazing sealing no. 611 and no. 619 are secured in the corners with a sealing compound.

Glass Installation

The function of the padding is to support, center and bear the vacuum-sealed window in the frame as planned, and to ensure that the window or door stays in the correct shape. There are two types of pads:

- bearing pads, which transfer the weight of the pane to the frame.
- supporting pads, which prevent the pane from moving when in use.

The bearing pads must be made of a shape-retaining and durable plastic with a hardness of 70-90° Shore A, or another suitable material for the purpose. Pads made of another compatible material must be of an equal hardness. A disjointable pad can not be used.

The temperature fluctuations that the R12 structures may be susceptible to may not effect the hardness of the pads.

The length of the bearing pads must be 100 mm, and the bearing width of the pad must not be less than the thickness of the glass pane. The thickness of the bearing pads is 5 mm.

The length of the supporting pads can be 50-100 mm depending on the size of the pane, and the width the same as the bearing pads.

The pads are installed 50-100 mm from the corner of the pane.

The illustrations show the location of the pads in the most common types of doors and windows.

Glazing instructions are valid only for vertical structures.

These glazing instructions are a matter of principal only.

Naturally, we are not responsible for the actual glazing work which we do not control.

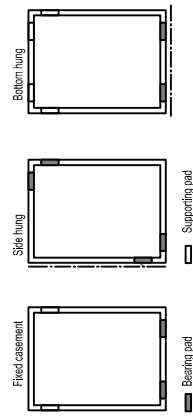

Placement of pads:

Choice of glazing beads in connection with sealings 619 + 612

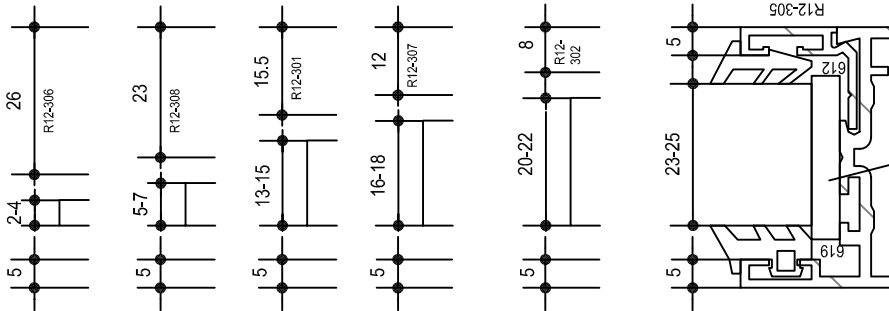

Vacuum glass pad 100x29x5
Rolled glass pad 100x10x5

Choice of glazing beads in connection with sealings 611 + 612

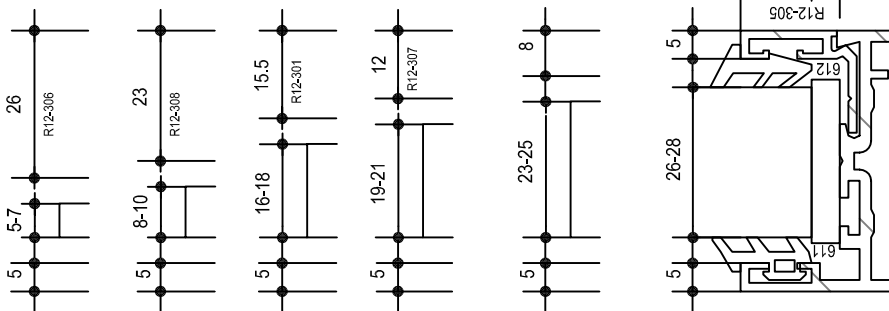

Sealings



Choice of glazing beads in connection with sealings 611, 630 + 612

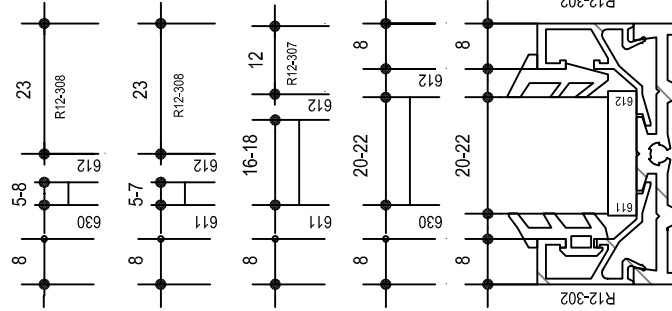

choice of glazing beads in connection with sealings 611, 630 + 612

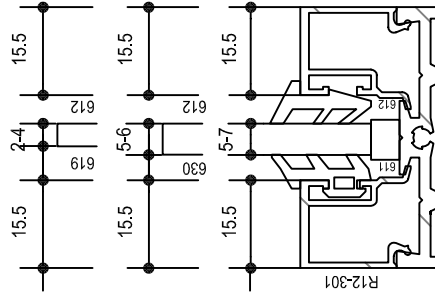

Light opening measurement

Glass measurement=light opening measurement+24

Margin of adjustment

Nokian Profiles R12 Work description

ENG

1. Type
Thermally non-insulated, aluminium frame partition walls, entrances, and doors are manufactured of the building system in accordance to the R12 system.
2. Materials
The aluminium profiles are of alloy EN AW 6060 T6
3. Surface treatment
* Anodization
The surface treatment of the aluminium profiles is the light and weatherproof anodization.

NORDIC EN 000	<input type="checkbox"/>	Euras C-0
NORDIC EK 22	<input type="checkbox"/>	Euras C-31
NORDIC EK 24	<input type="checkbox"/>	Euras C-32
NORDIC EK 26	<input type="checkbox"/>	Euras C-33
NORDIC EK 29	<input type="checkbox"/>	Euras C-33
NORDIC EK 30	<input type="checkbox"/>	Euras C-35
- * Painting:
Polyester powder coating baked in a desired colour, chromated for primer treatment.
Colour shade
4. Fittings
The fittings of doors follow the door specification and instruction **10 30** - **10 33**
Automatic doors according to **10 28**
5. Glazing
The type of glazing is
The glazing and the choice of accessories is based on the glazing instruction **10 35**
6. Sealings
The glazing sealings are form strips of EPDM rubber. The sealings of door rebates are form strips of EPDM rubber, the bottom sealings are brush sealings, and the sealings in the partitioning doors are e.g. fiber frax ribbon.
7. Mounting
The R12 structures are mounted using the joints, angle joints, screw slots, and sealings. The joining points are machined and mounted carefully and sealed. The clamp angles are secured with Araldit glue. The used screws and rivets in the outer walls are of aluminium or stainless steel or anti-corrosion treated.
8. Mounting into the building framework
The structures are fixed into the building framework in such a manner that the loads on the structures are transferred in a reliable way on the structural frame and that neither the deformations nor the thermal movements of the building framework could harm the aluminium structures. The seam between the aluminium structure and building framework is sealed in a functional manner
9. Protection during the on-going building
The visible surfaces of the aluminium structures should, if needed, be protected against foundering and rendering splashes and welding spatters as well as against mechanical damages during the work.
10. Functional requirements
The structure must stand the loads in accordance to the regulations and transfer the loads on the building framework.

Comments on the work description

1. The system includes also instructions on glazing, mounting, draining, ventilation and insulation ao. details contributing to a good result.
2. The EN AW 6060 T6 is a strong ($R_{p0,2}=150 \text{ N/mm}^2$) aluminium alloy that can be easily anodized and extruded into complex forms.
3. Nordic EK is a two-phase method creating a permanent colour. For colour shades see the models.
The shades EN 000 (natural anodized) and EK 26 (dark brown) are available from stock.
The profiles can also be baked with a polyester painting.

Painting:
For standard shades see painting charts.
The painted profiles are always manufactured upon order.
4. Door fittings, see coloured brochure:
Hinges page 30, for heavy-use doors 3-leaf and/or 3 pcs of 2-leaf hinges
Closers page 29-30, entrance doors must be equipped with opening brakes
lever bolt, side bolt, pullers page 33
5. The total thickness of the solid part is max. 32 mm when it is mounted using glazing beads.
6. It is possible to use also bottom ribbon 630 and rabbit putty instead of the glazing sealing.
8. In the sheet **10 36** are some examples of mounting.
9. Against rendering splashes a proper protection is e.g. plastic film or protective lacquer.
10. In the pages **10 11** and **10 20** there are design diagrams for choosing the correct structural size.
If the loads differ from those in a normal case (wind load area A, $h < 5 \text{ m}$) this must be taken into account in the designing.
The applied designing principle for the external wall is: tension below the allowed tension according to the RIL 87 "Aluminium structure standards", deflection under $l/200$.



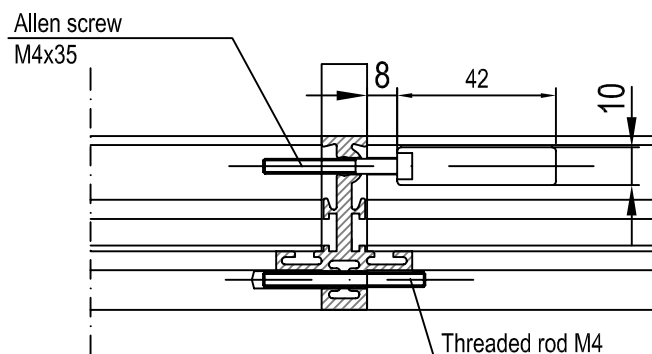
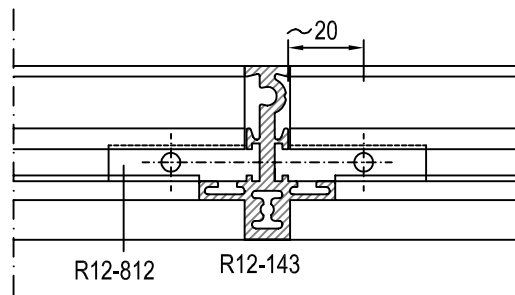
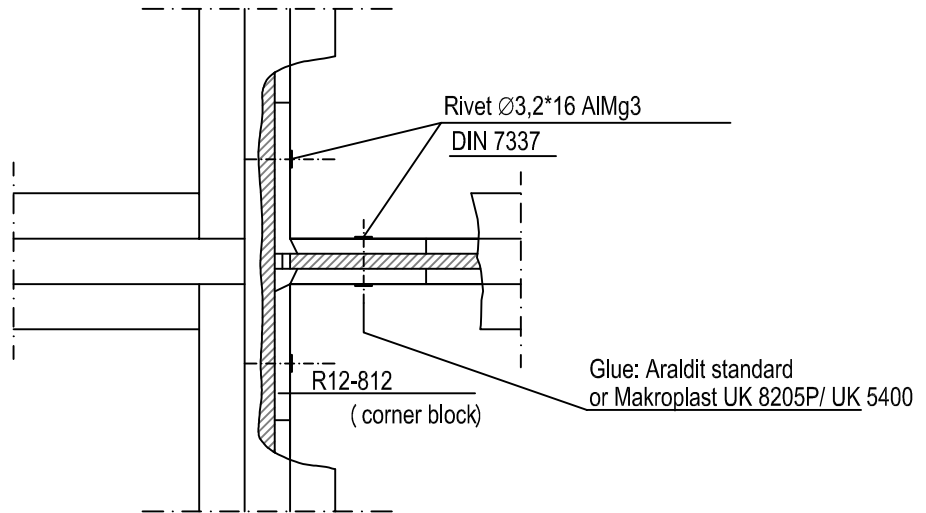

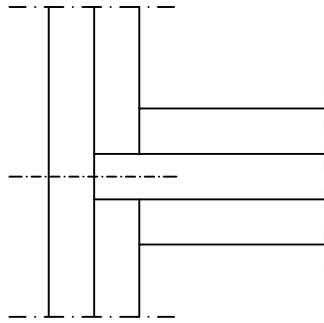

Sheet screw
4,2*19 SFS 2759 A2

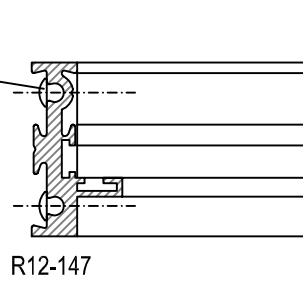

R12-147

Machining of transome R12-143

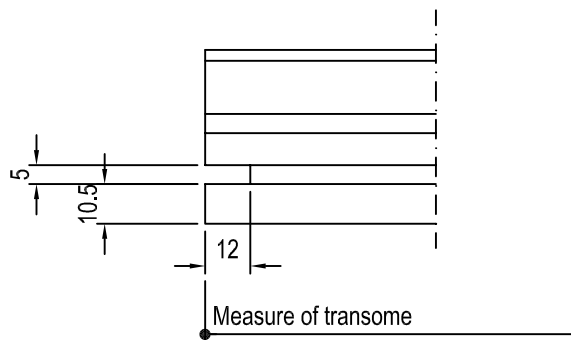

Corner in wall

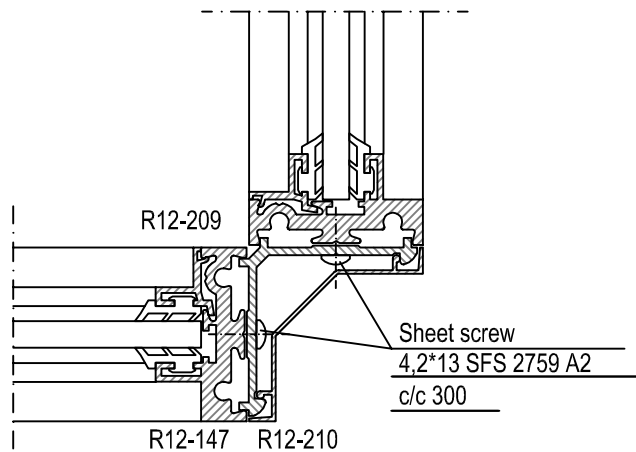

Fixing to wall

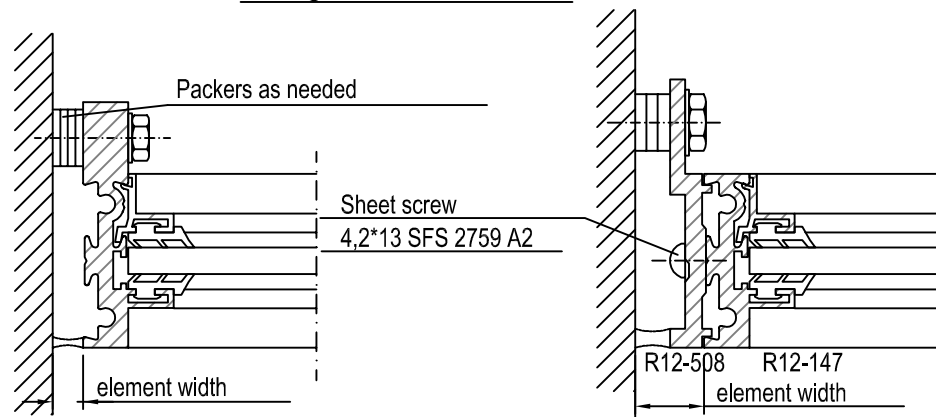

Note! Profile R12-508 could be used as piece or as full length

Partition floor fixing

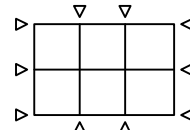
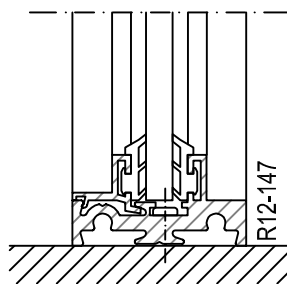

Fixing points should be located to ends of mullions and transoms

Floor fixing

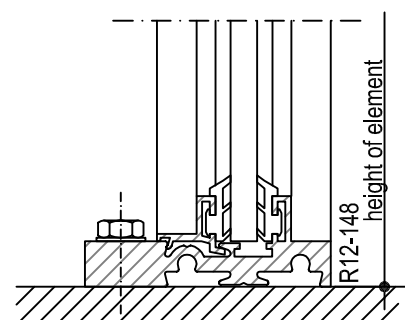
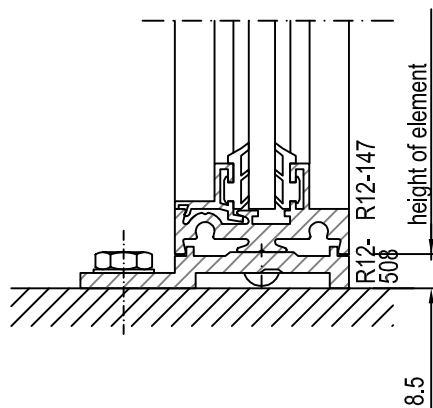

01.07.2013

Choice of glazing beads in connection with sealings 611 + 611

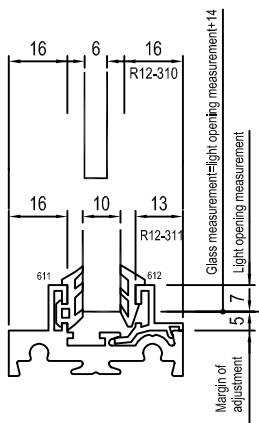

Choice of glazing beads in connection with sealings 611 + 612

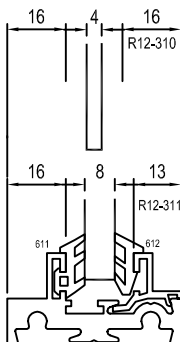

Choice of glazing beads in connection with sealings 619 + 612

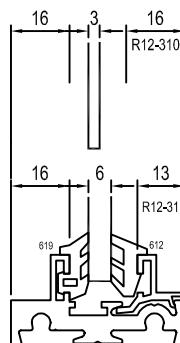

Choice of glazing beads in connection with sealings 615+ -

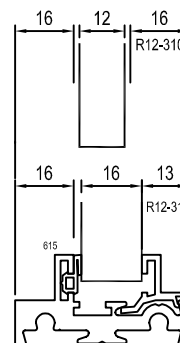

GLAZING

Before commencing glazing, ensure that rebates glazing beads and glass are clean. Then fit the exterior glazing sealing no. 611, 619 or 630 into the profile groove.

A suitable lubricant can be used to facilitate the installation of gaskets.

When cutting sealing gaskets, a shrinkage allowance of 0,5% must be observed.

On exterior structures, sealing gaskets are secured in the corners with a sealing compound.

GLASS INSTALLATION

The function of the pads is to support, centre and bear the vacuum-sealed window in the frame as designed, and to ensure that the window or door stays in the correct shape.

There are two types of pads:

- bearing pads, which transfer the weight of the pane to the frame.
- supporting pads, which prevent the pane from moving when in use.

Note! Glass of doors, windows and glass on the edge of hole glue with elastic mass. This way profiles deflection has restraint.

The bearing pads must be made of a shape-retaining and durable plastic with a hardness of 70-90° Shore A, or another suitable material for the purpose. Pads made of another compatible material must be of an equal hardness. A disjointable pad can not be used.

The temperature fluctuations that the R12-LINEA structures may be susceptible to may not effect the hardness of the pads.

The length of the bearing pads must be 50-100 mm, and the bearing width of the pad must not be less than the thickness of the glass pane.

The thickness of the bearing pads is 5 mm.

The length of the supporting pads can be 50-100 mm depending on the size of the pane, and the width the same as the bearing pads.

The pads are installed 50-100 mm from the corner of the pane.

The illustrations show the location of the pads in the most common types of doors and windows.

These glazing instructions are given only in principle and are valid only for vertical structures we therefore accept no responsibility for actual glazing work carried out that we are not personally supervising.

OPENING IN THE STRUCTURE

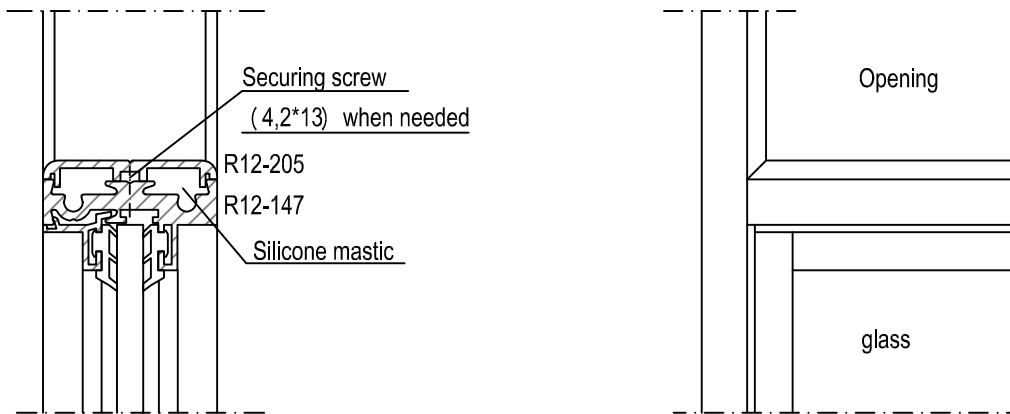

R12-205 machining and fixing

GLAZING LISTS

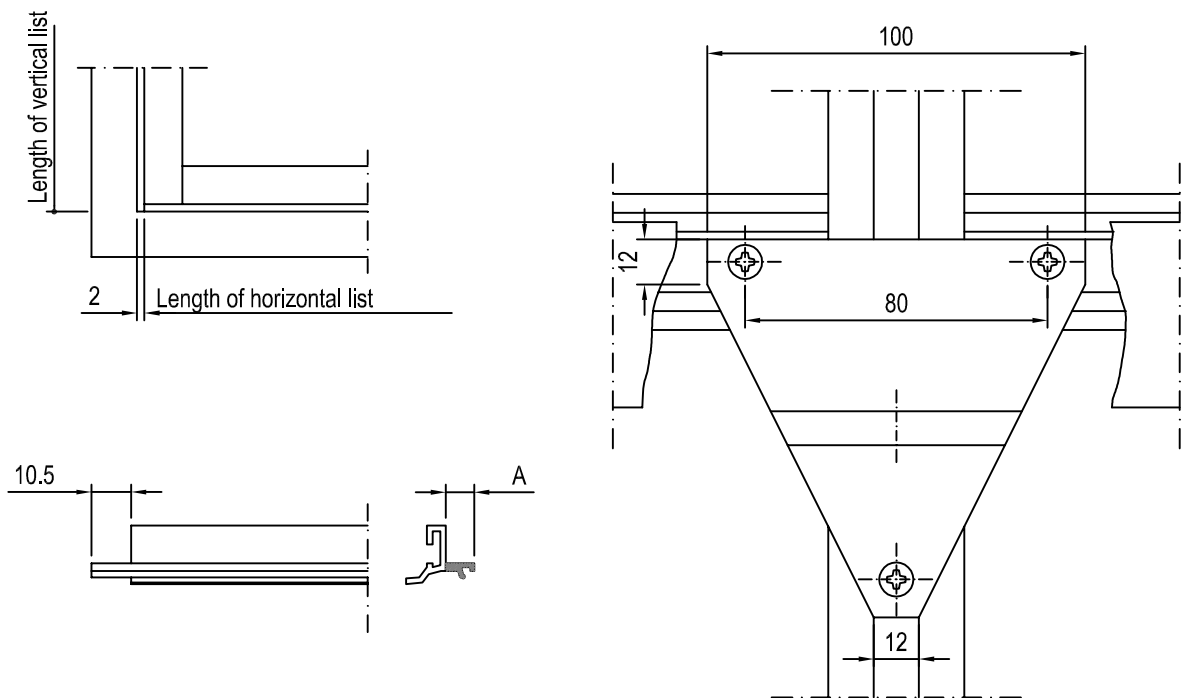

Measure	R12-310	R12-311
A	10,5	7,5

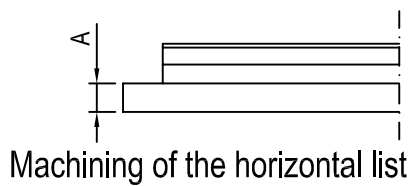

FIXING NET TO STRUCTURE

U-12x12x2x2 Al
prof. no 642

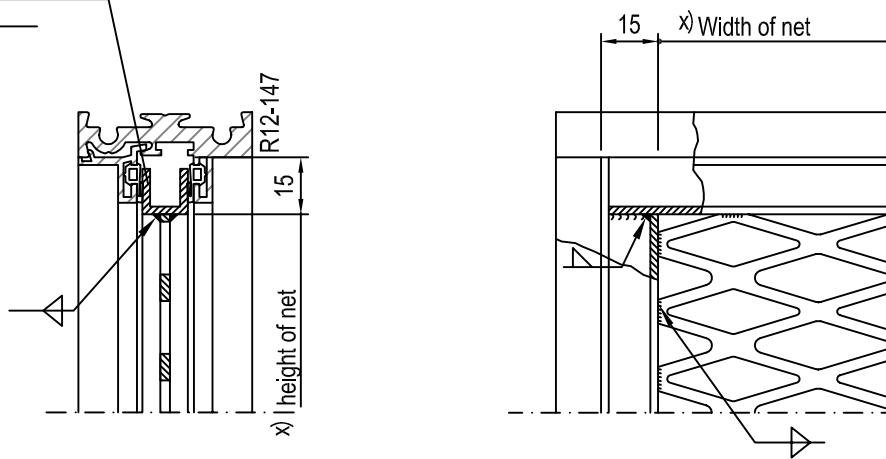

Expamet-2089A or similar

x) note the size of mesh

NOTE! Net element has to be anodized
after welding

BALUSTRADE

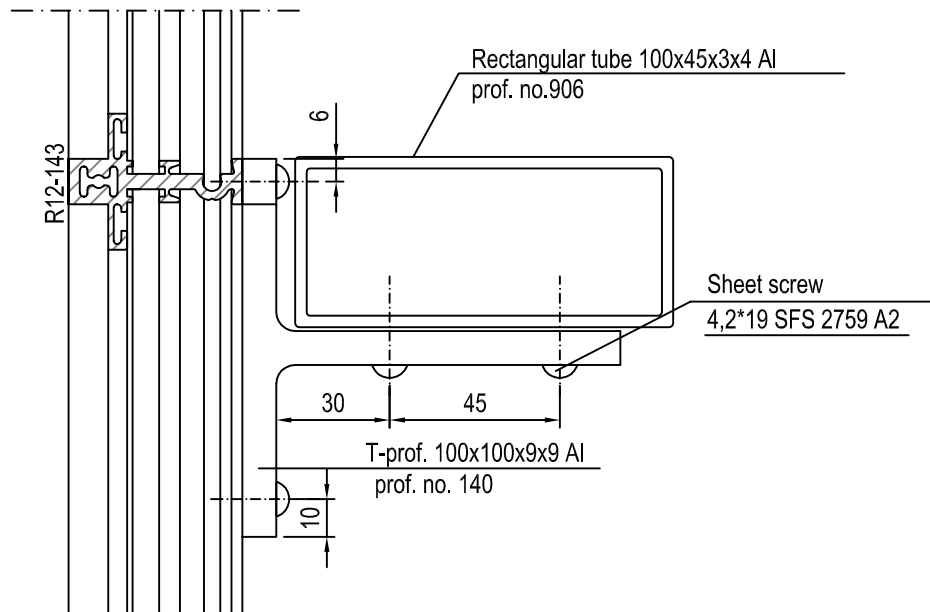

Balustrade fixing / machining of fixing piece

01.07.2013

R12
LINEA

48

NOKIAN
PROFILES

Balustrade, glazing lists

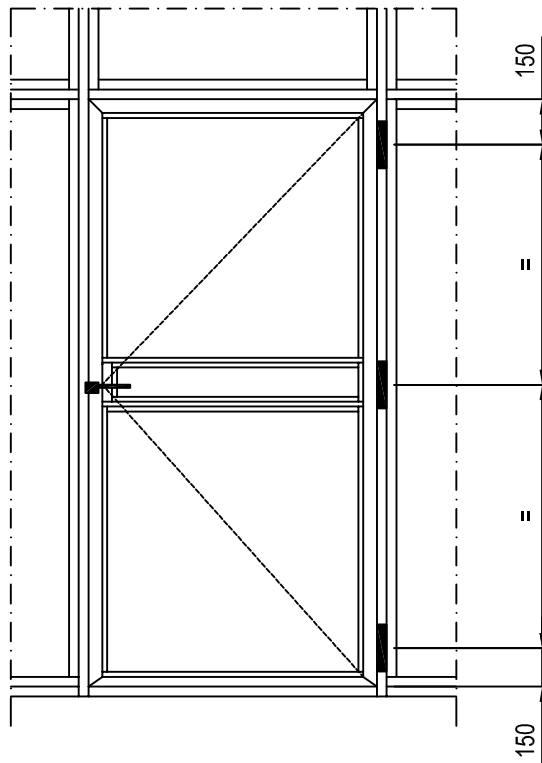
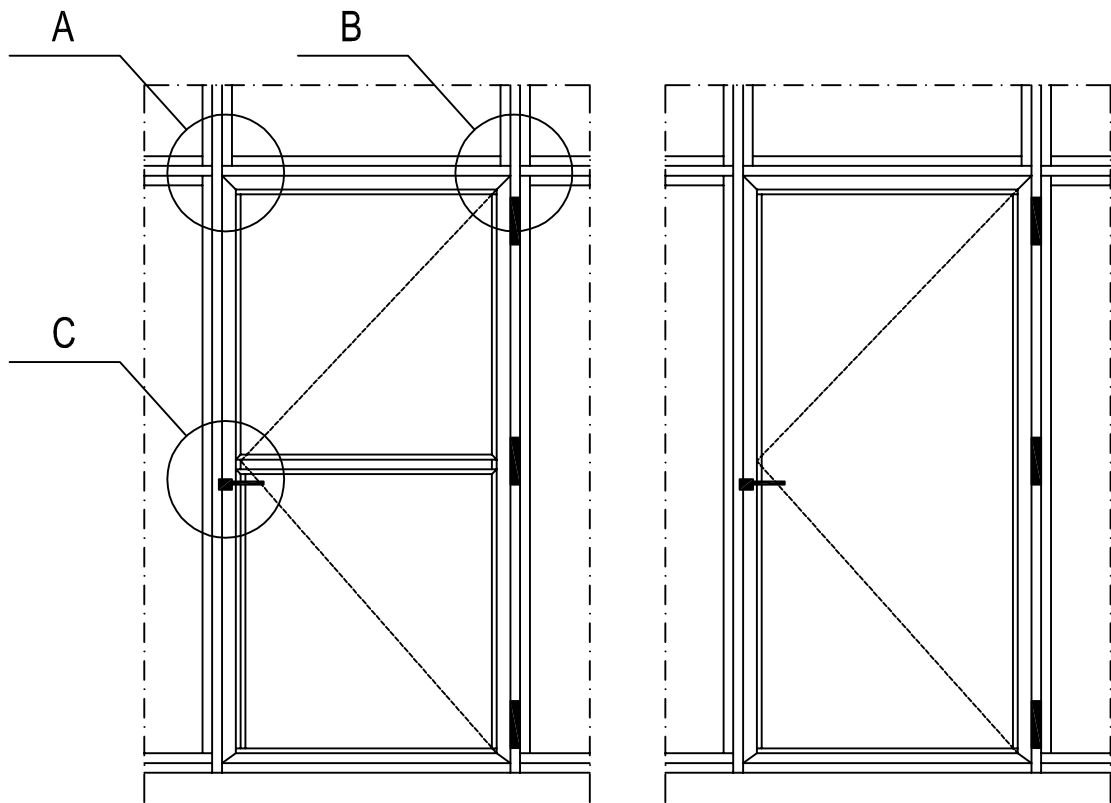

Profile R12-102 to be used with a door closer

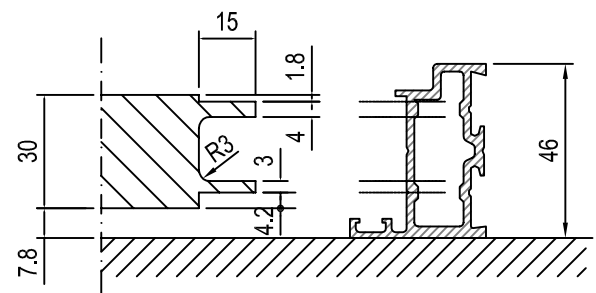
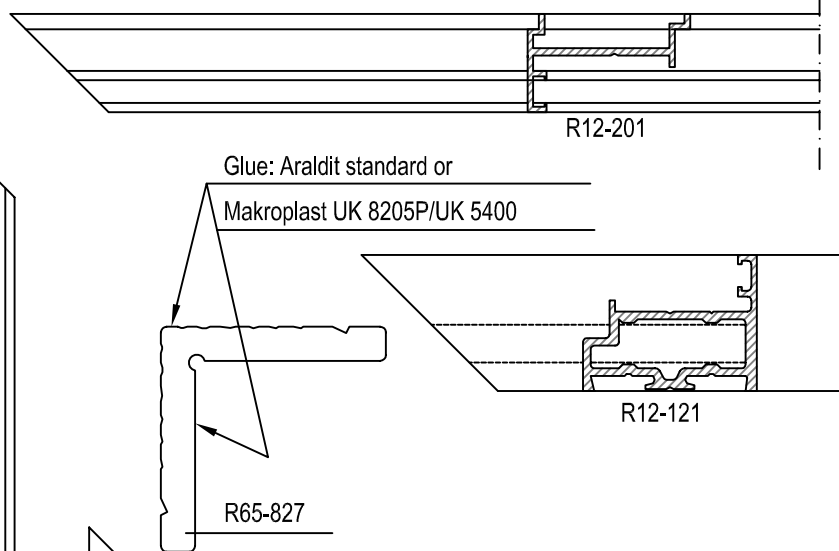

R12-201

R12-121

Corner joint

01.07.2013

Countersunk sheet screw
4,8*19 SFS 2760 A2

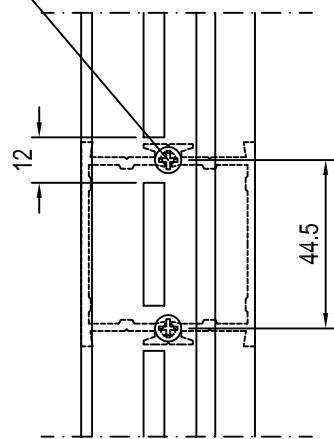

Fixing profile R12-102 to R12-147

DET. C

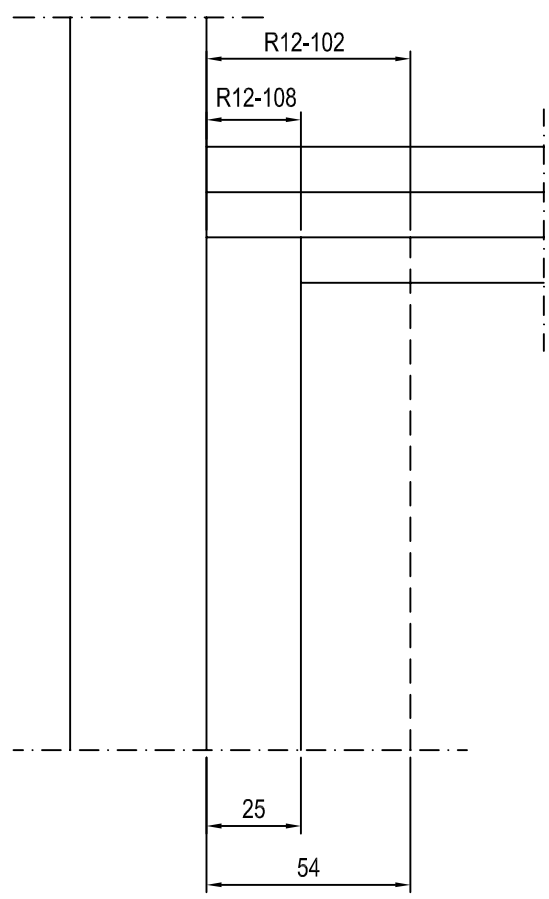

Machining transome R12-143
when connecting to R12-108 ja R12-102

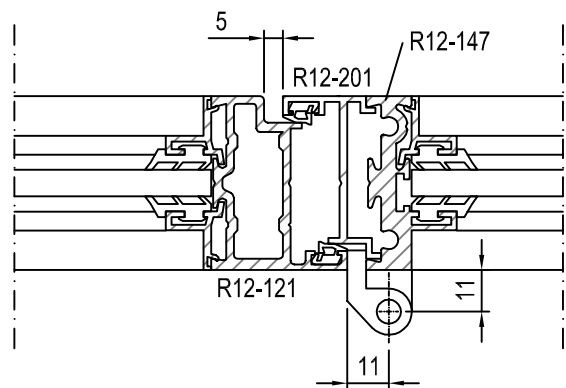
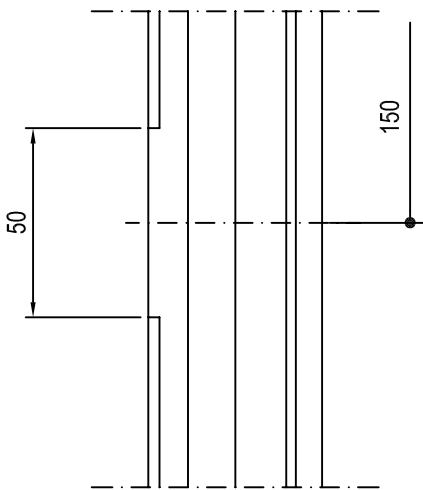
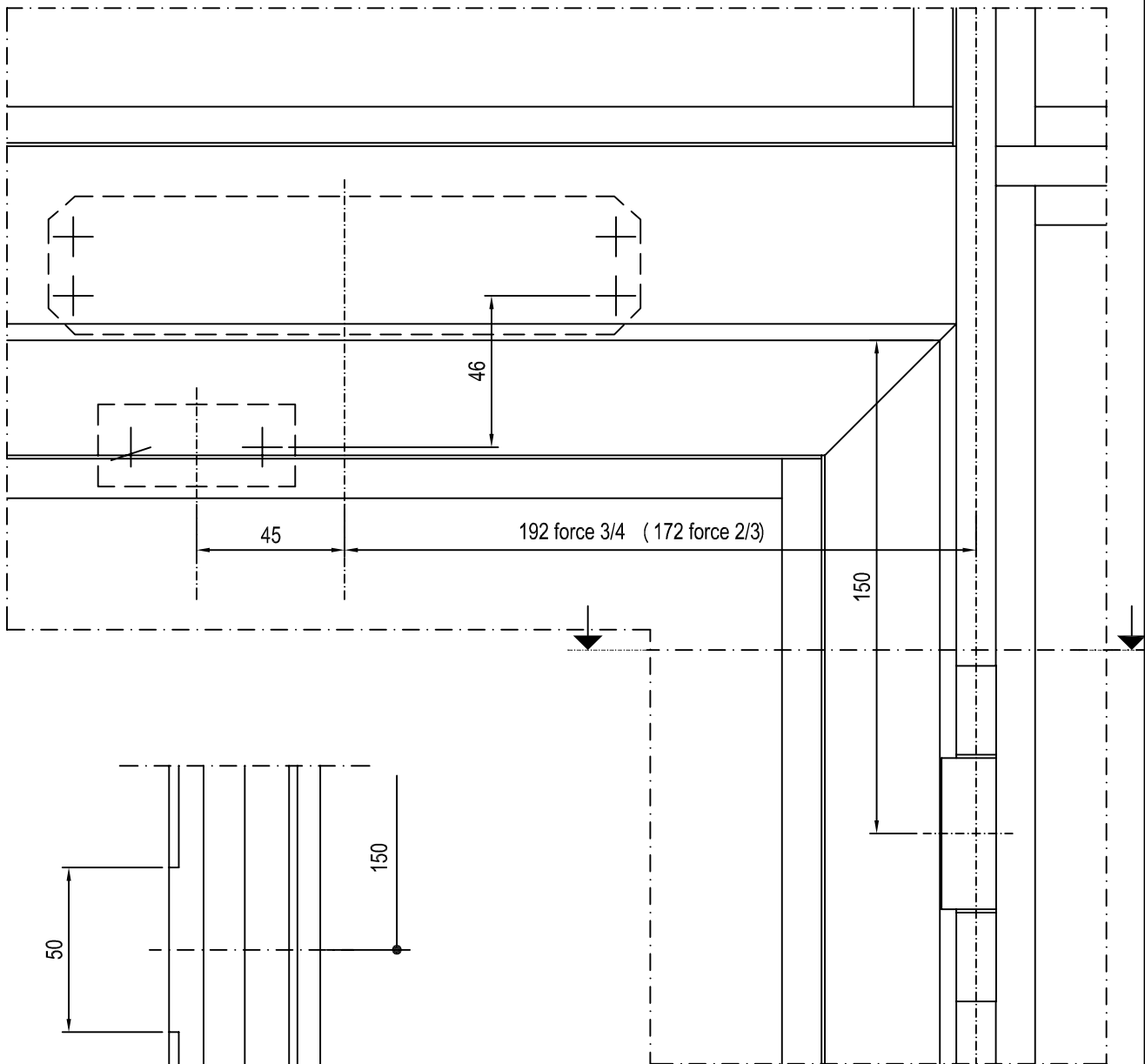

01.07.2013

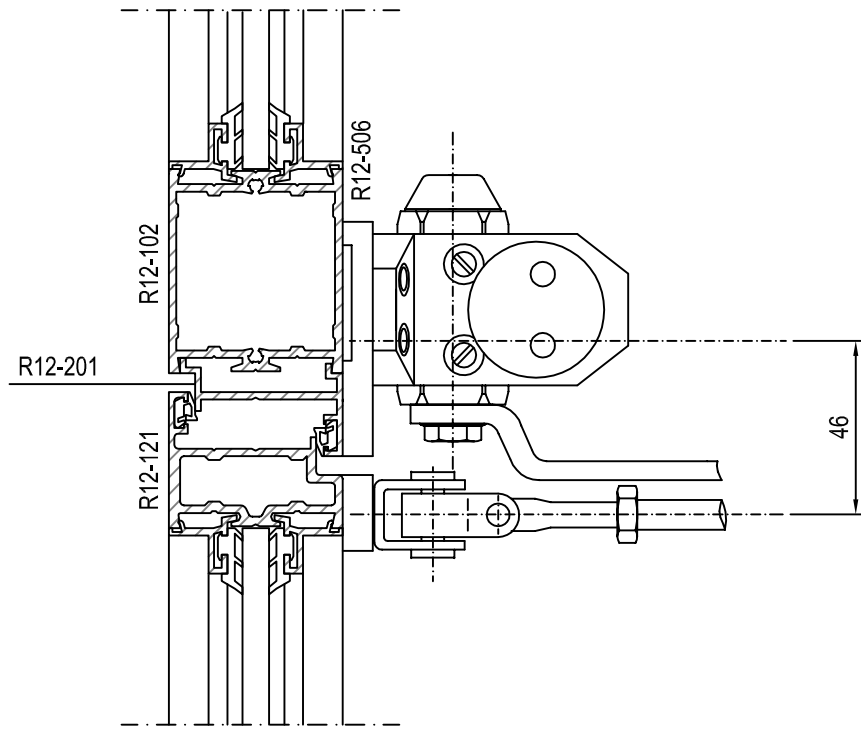

Adjustment of Roca DC-770 door closer

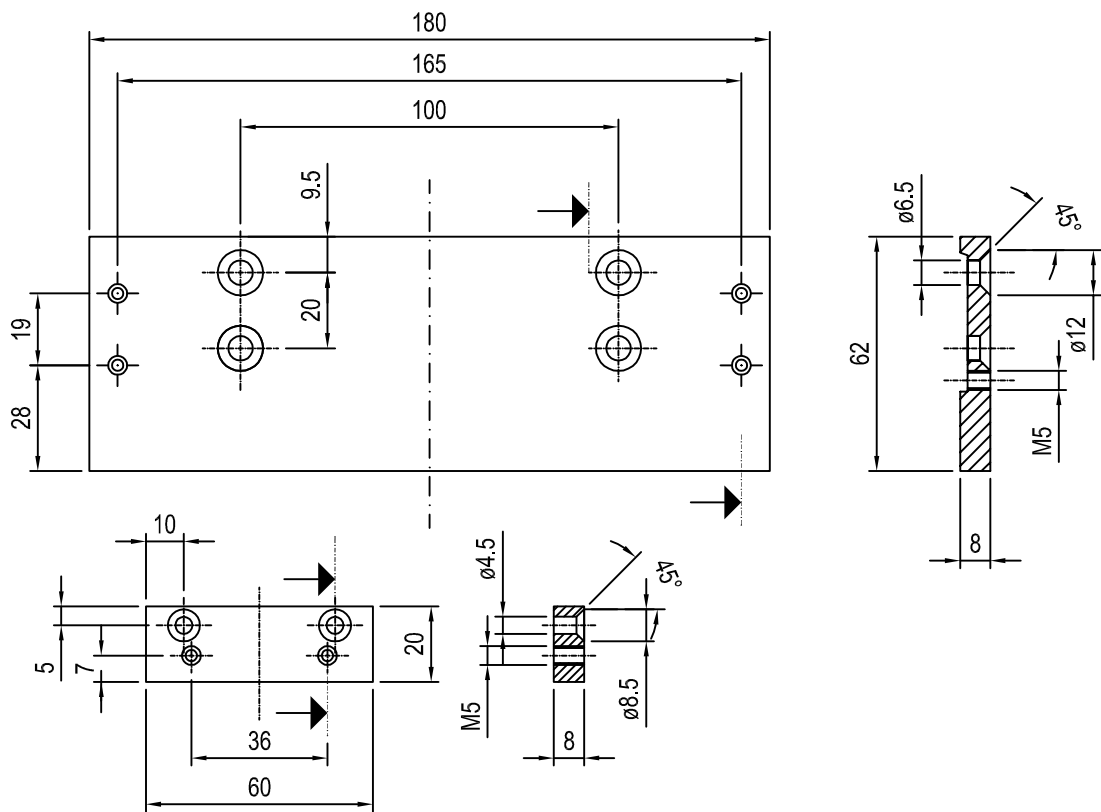

Manufacturing of Roca DC-770 door closer adjustment plate

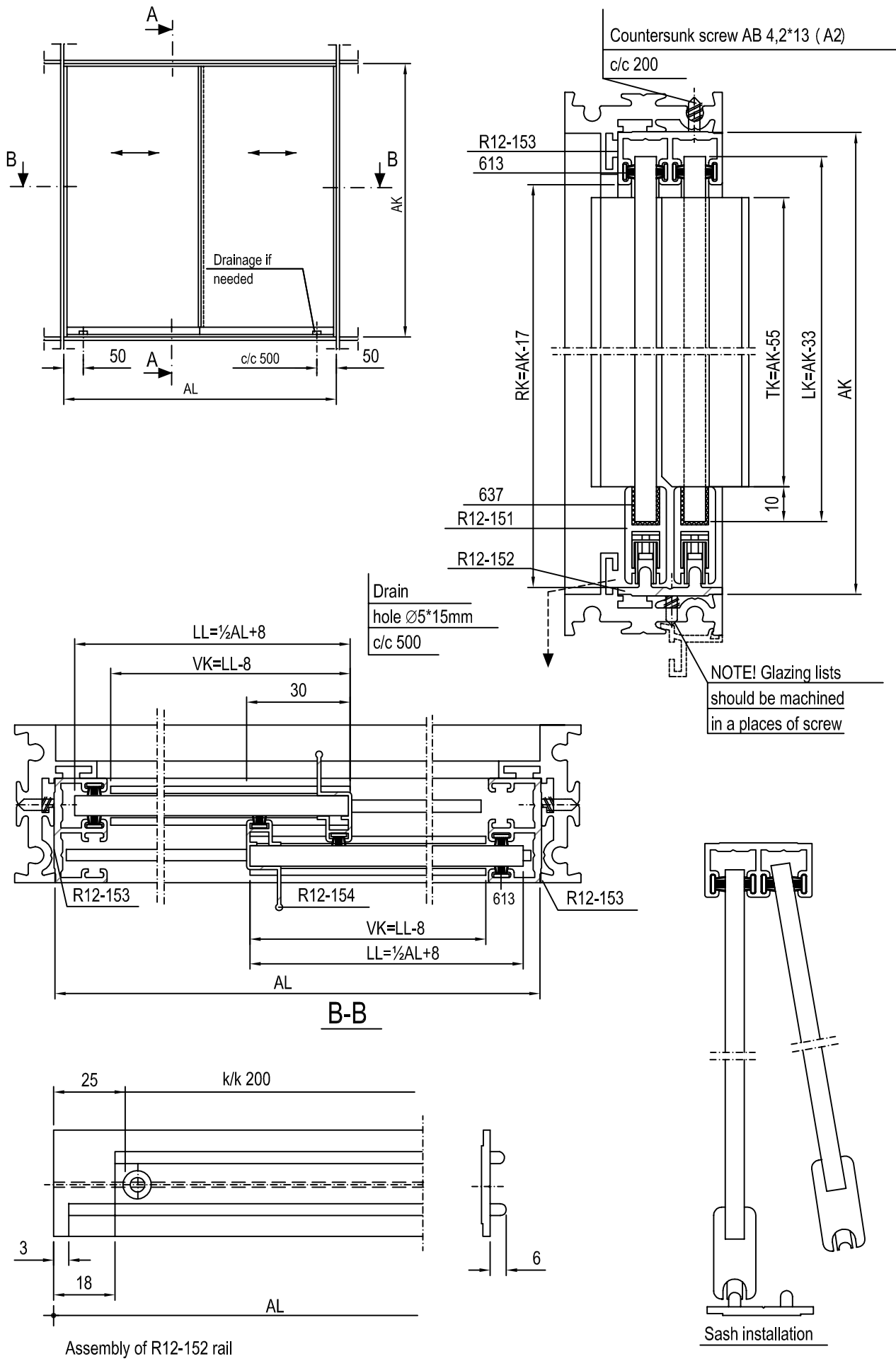

01.07.2013

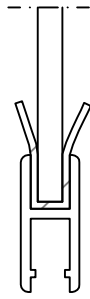

637 gasket adjustment

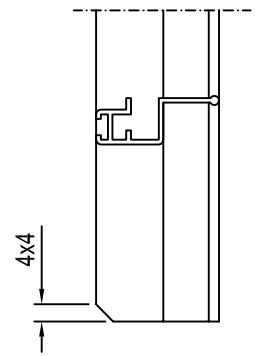
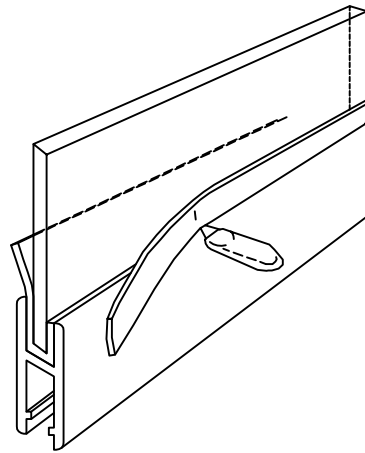

R12-154 machining

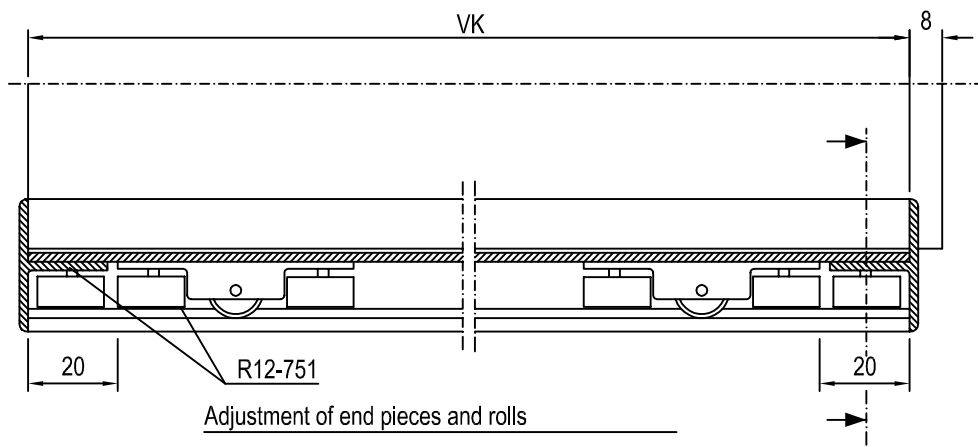

Adjustment of end pieces and rolls

Machining of end piece in case if glass goes over the profile

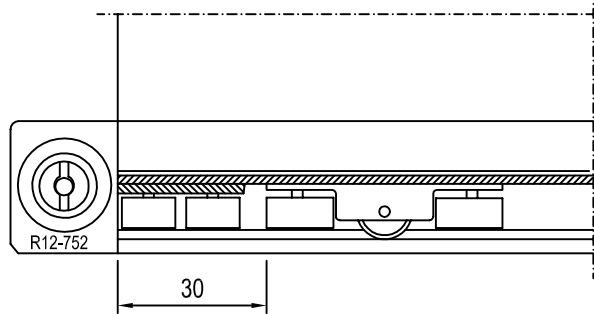

Adjustment of R12-752 lock

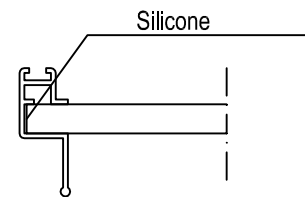

R12-154 adjustment to the glass

- AL = Opening width
- AK = Opening height
- LL = Glass width
- LK = Glass height
- VK = R12-151 profile length
- TK = R12-154 profile height
- RK = R12-153 profile height

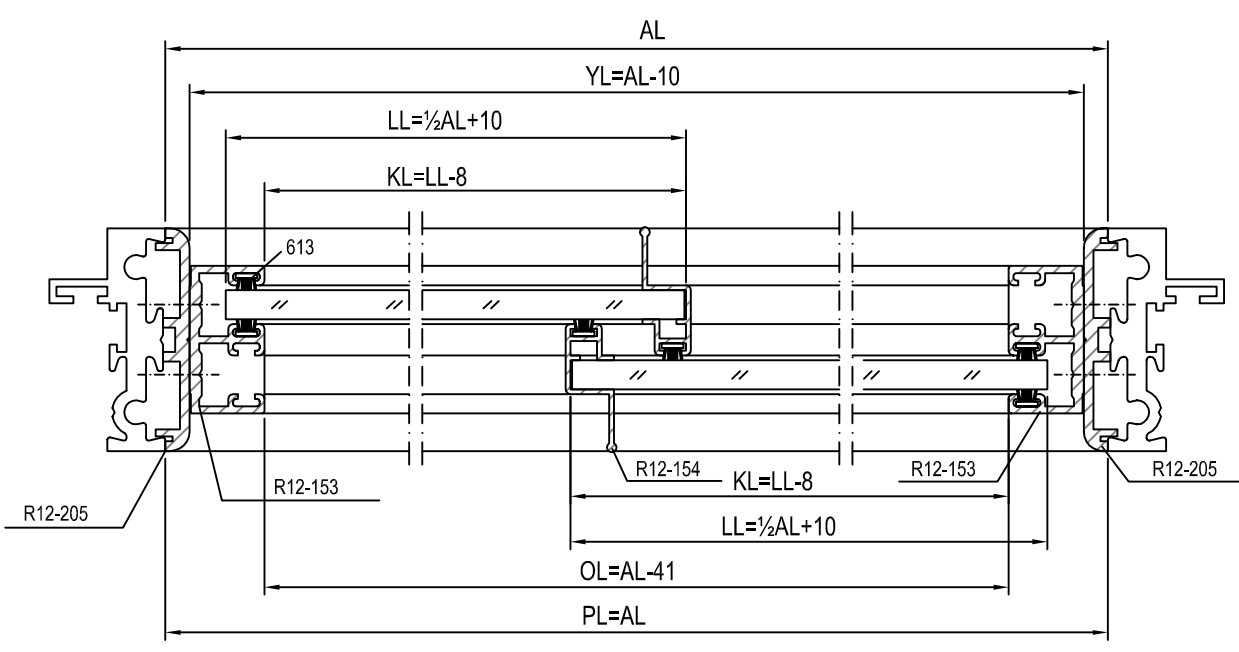
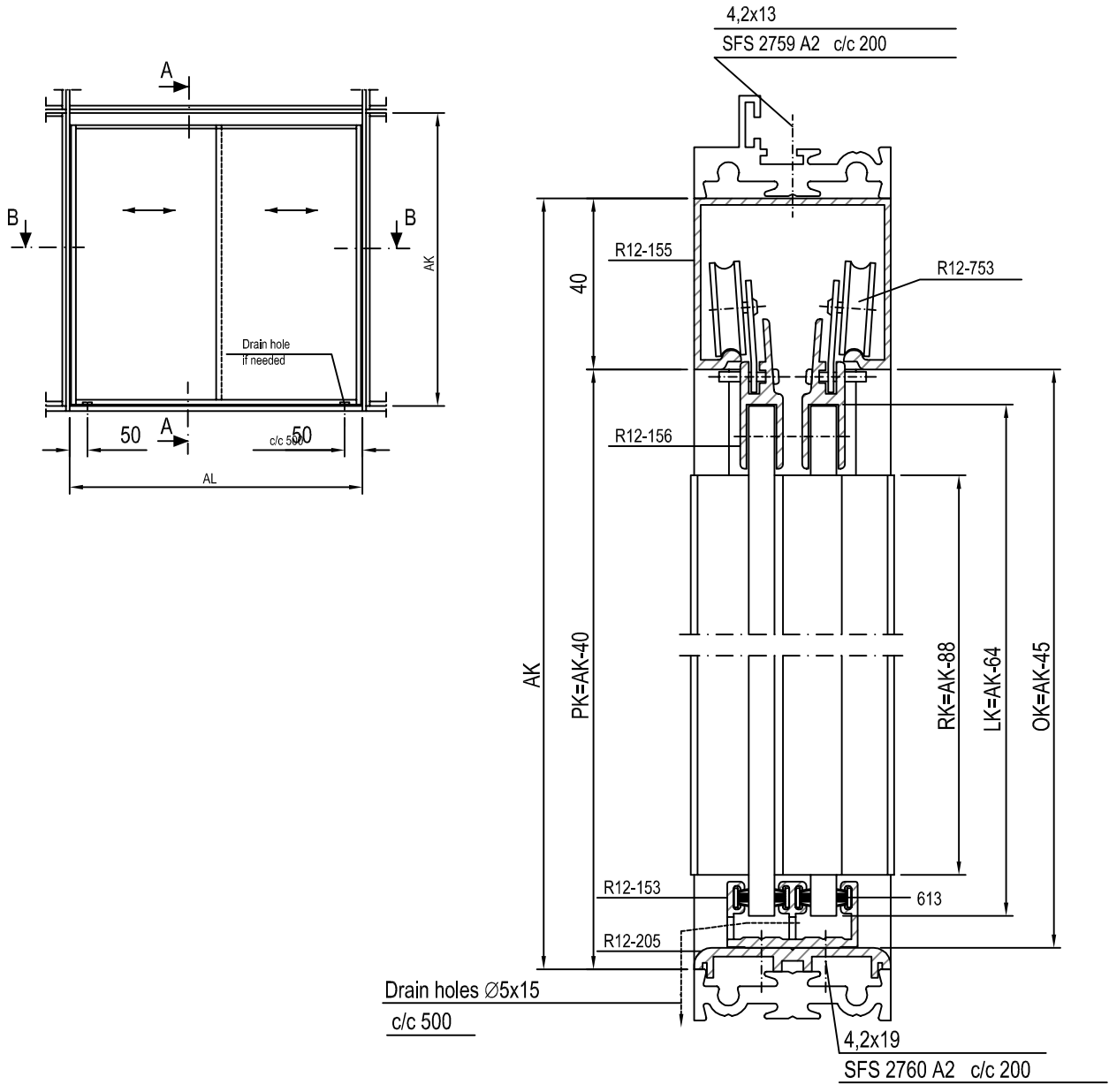

01.07.2013

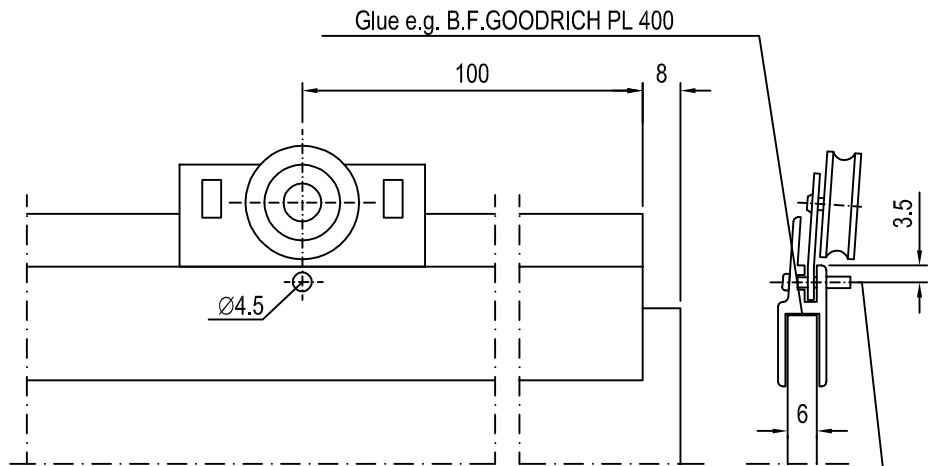

Adjustment of rolls and glass

In case of big glasses the structure is secured by screw and plastic sleeve

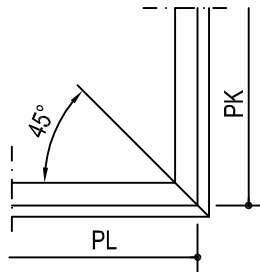

R12-205 machining

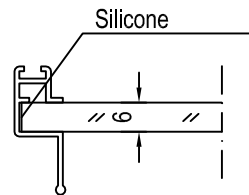

R12-154 adjustment to the glass

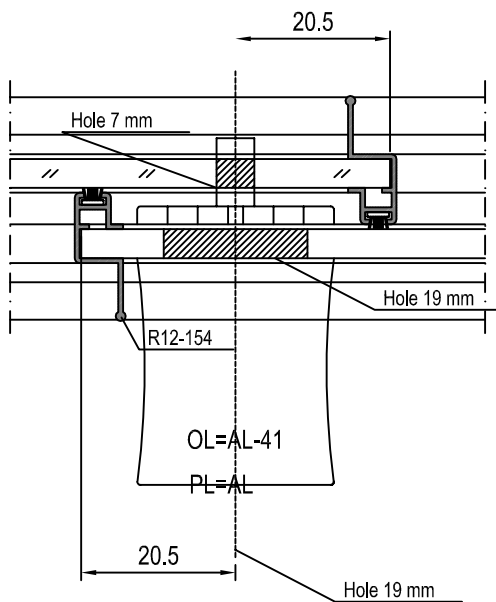

- AL = Opening width
- AK = Opening height
- LL = Glass width
- LK = Glass height
- PL = R12-205 width
- PK = R12-205 height
- OL = R12-153 width
- OK = R12-153 height
- RK = R12-154 height
- KL = R12-156 width
- YL = R12-155 width

NOTE! Glass lock can be adjusted e.g. Huwill 0688.001

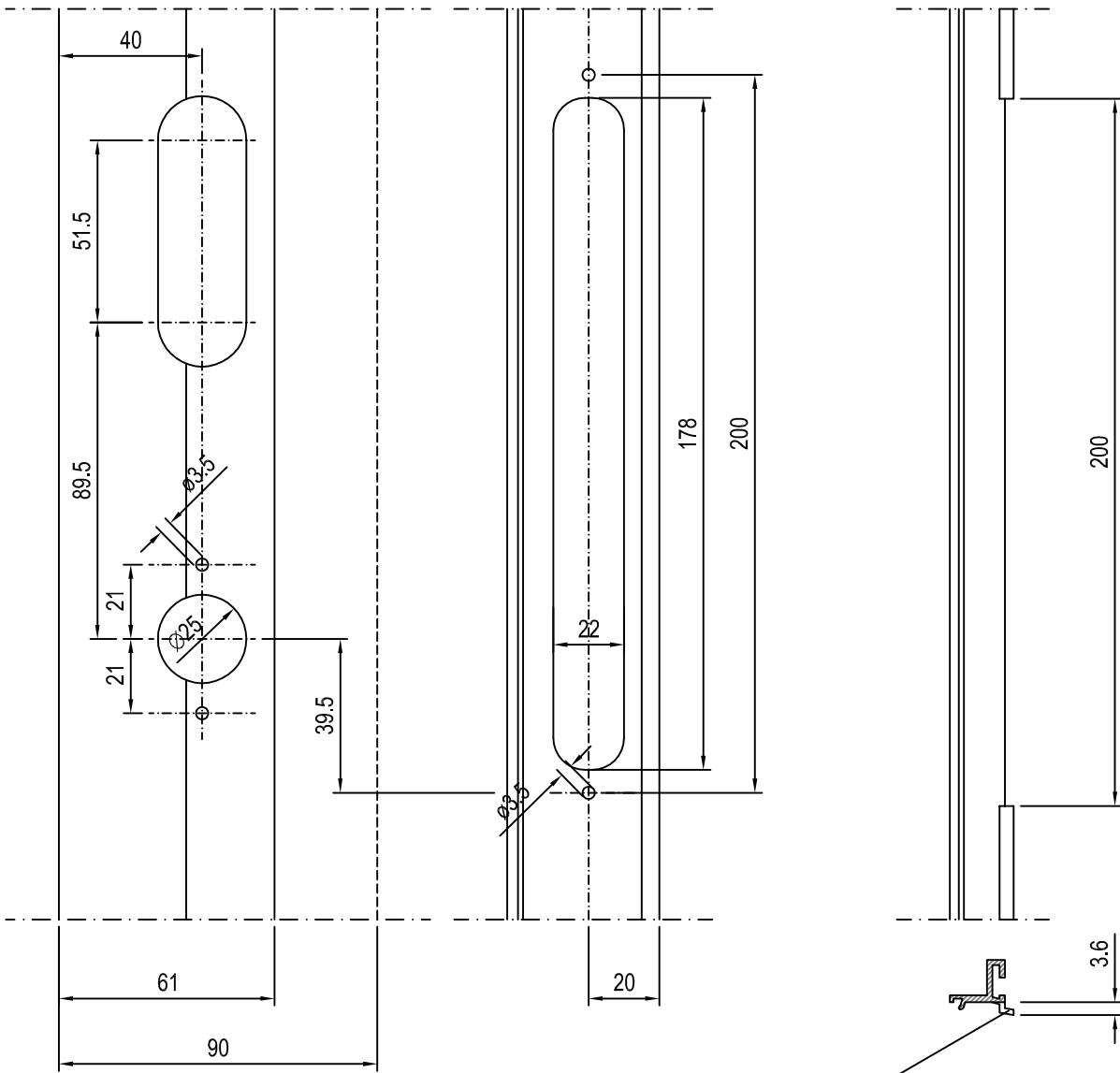

Abloy LC300, -1, -5 / 29

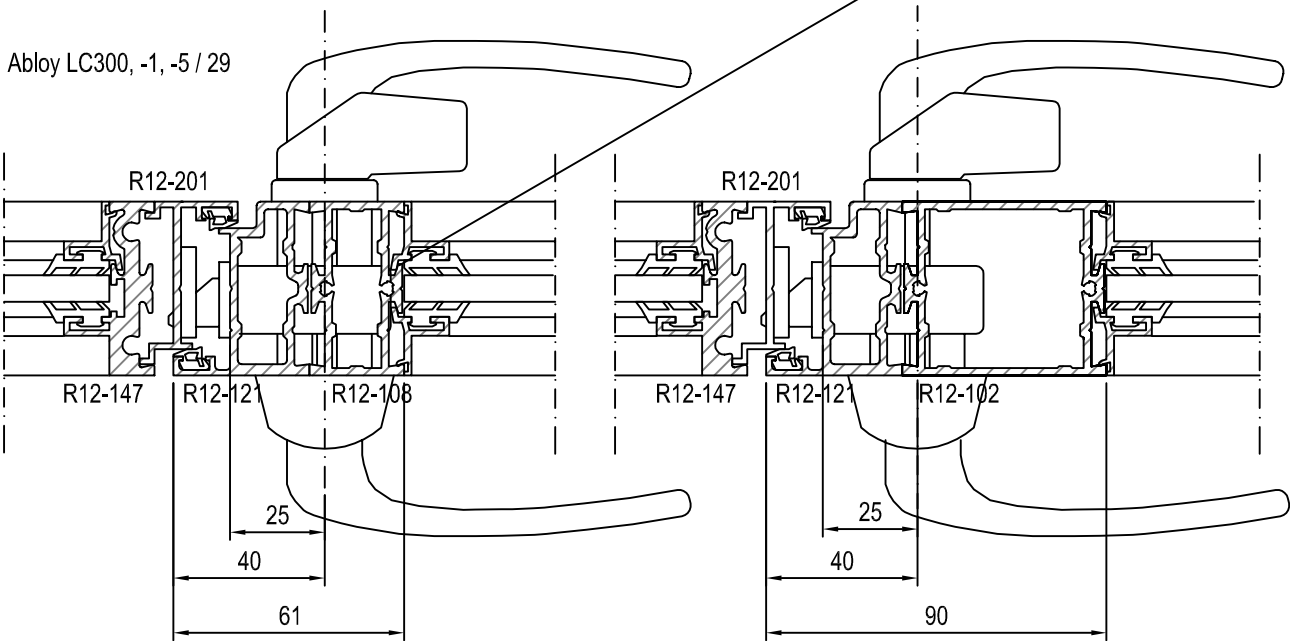

01.07.2013

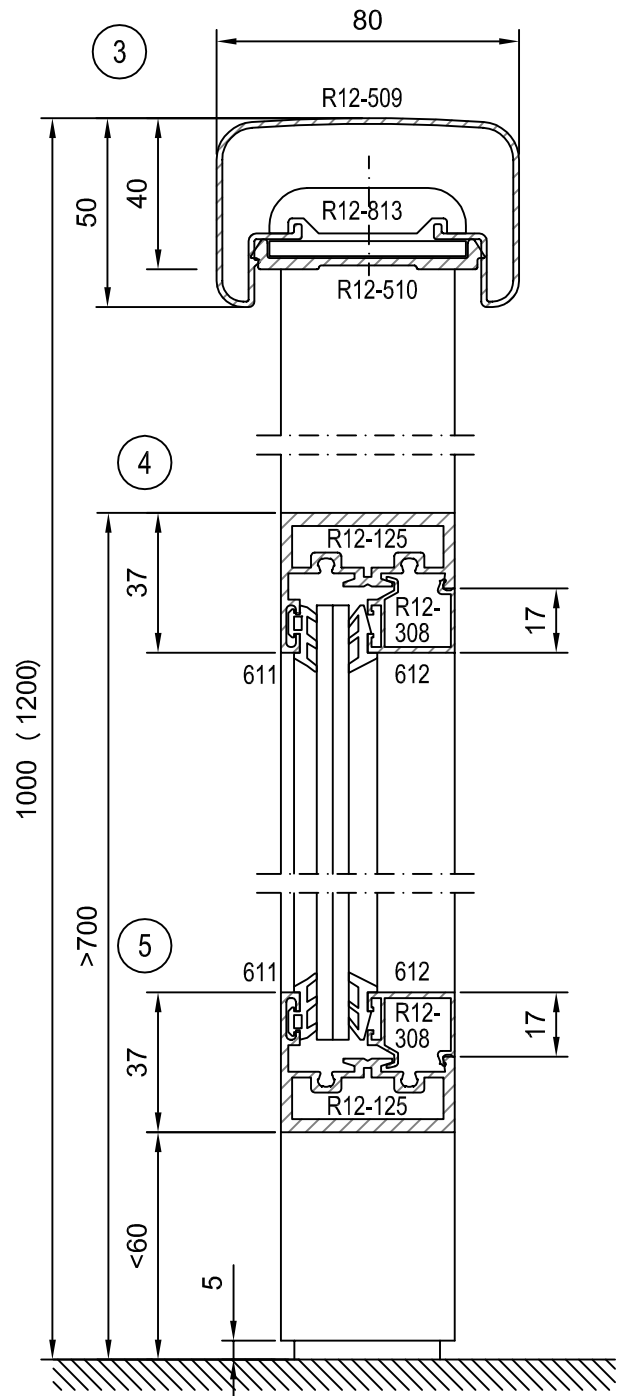
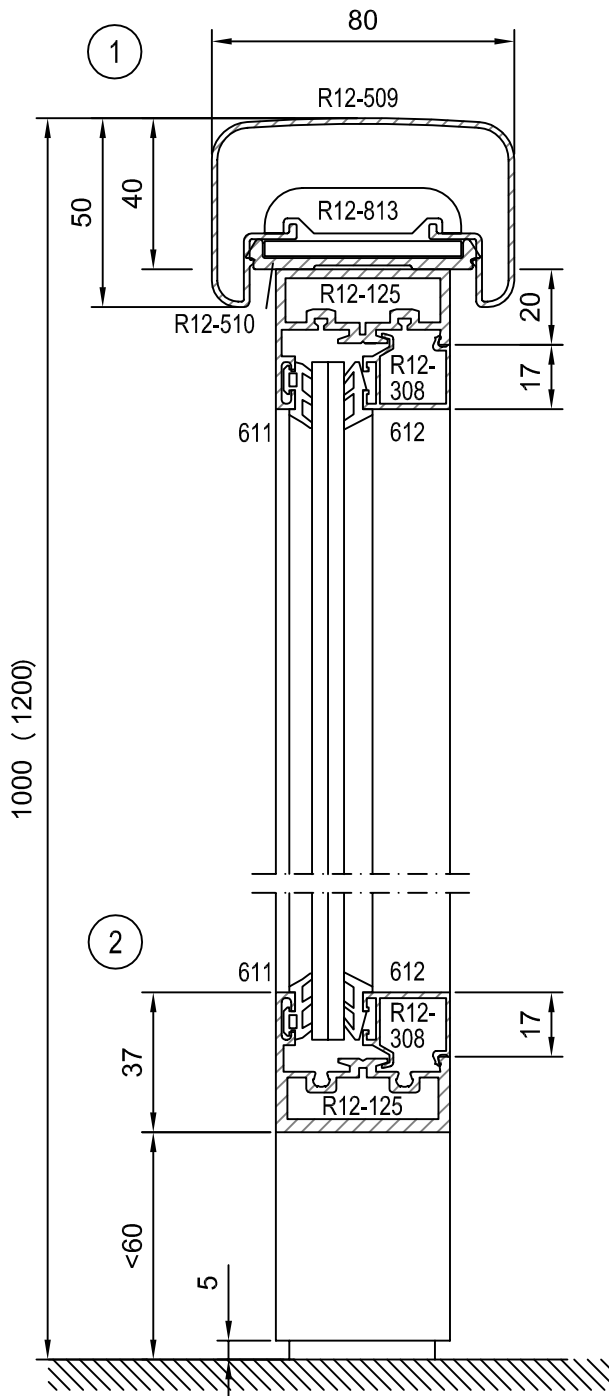
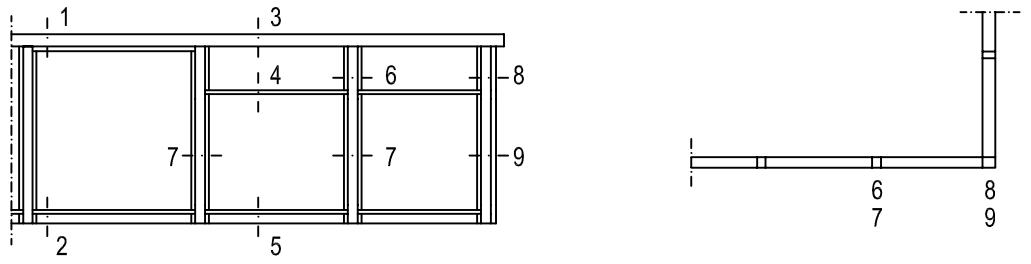

01.07.2013

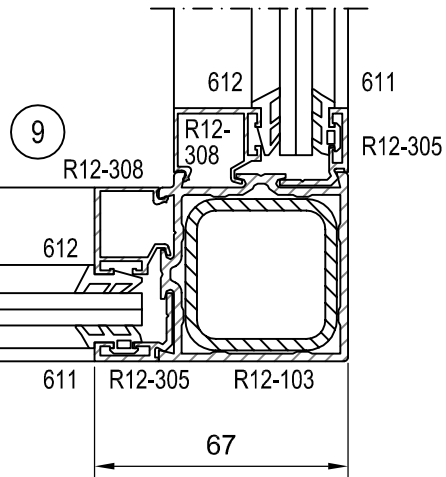
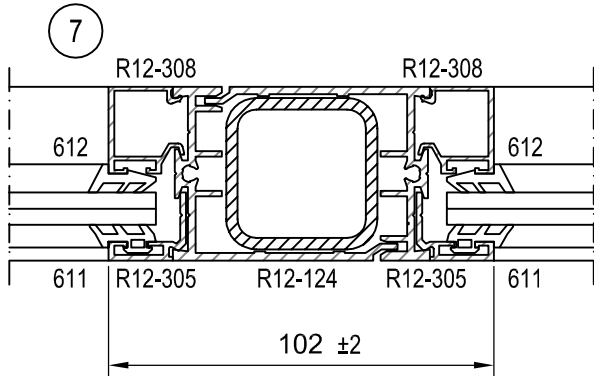
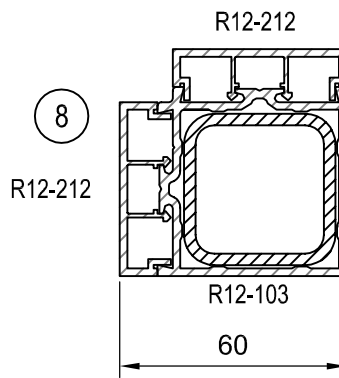
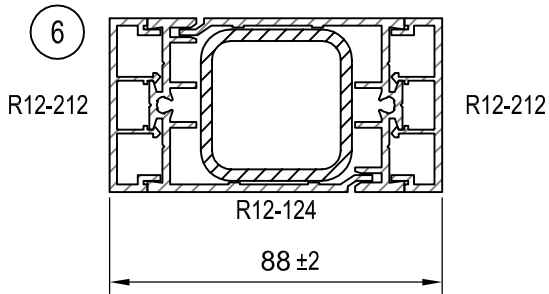
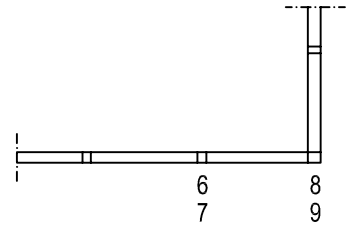
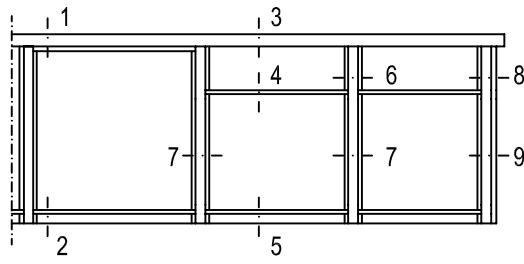

01.07.2013

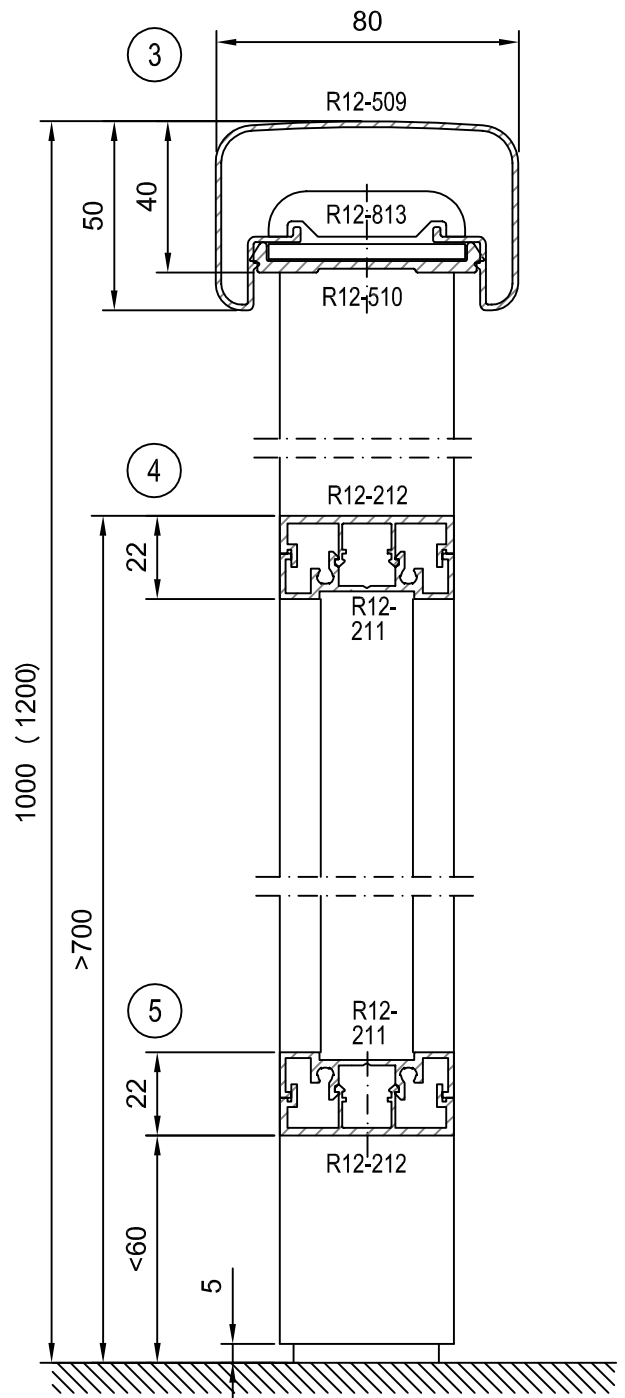
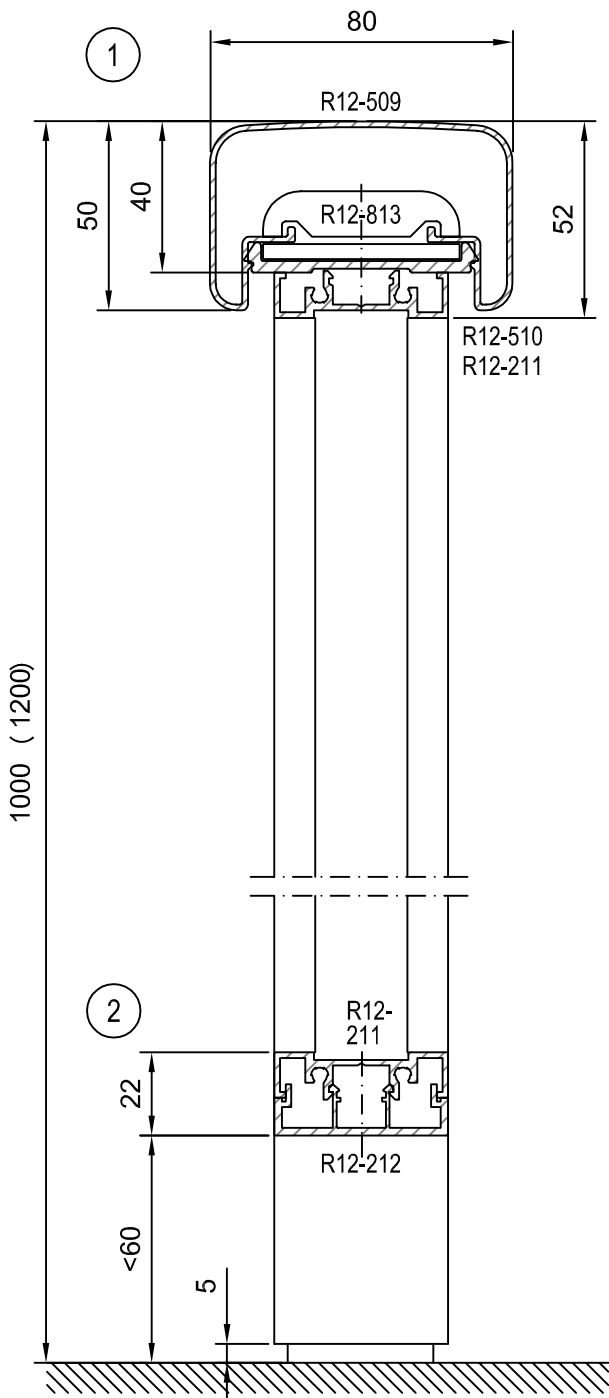
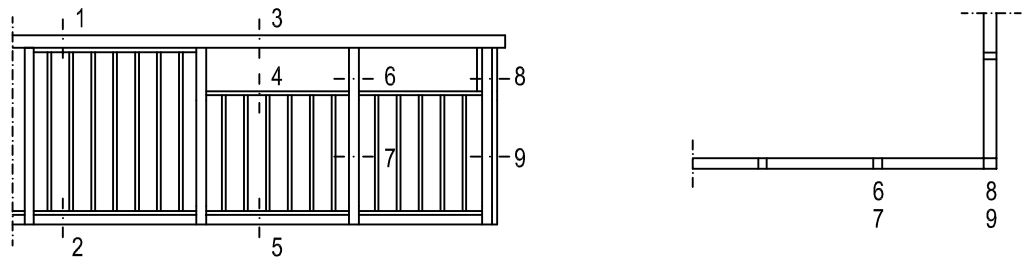

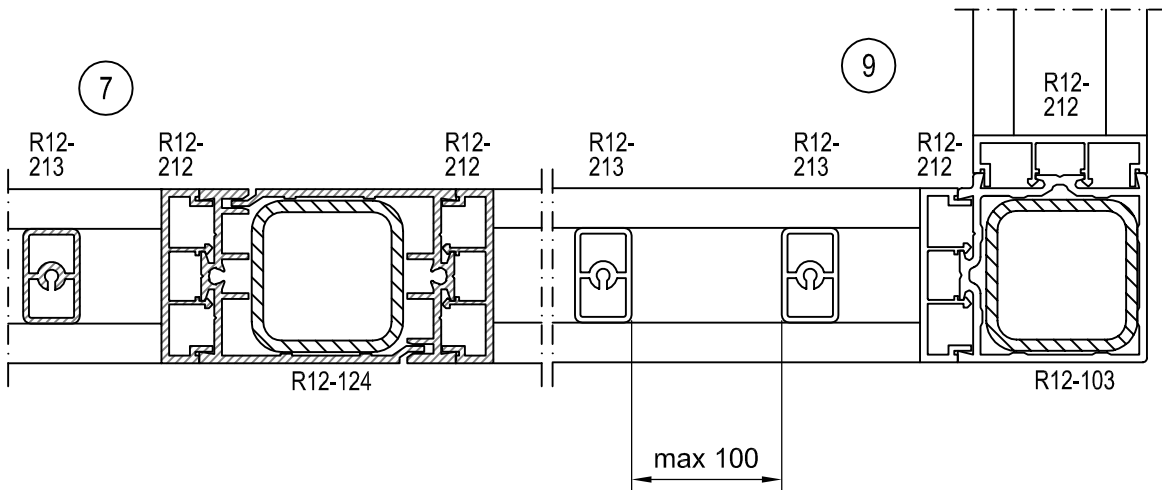
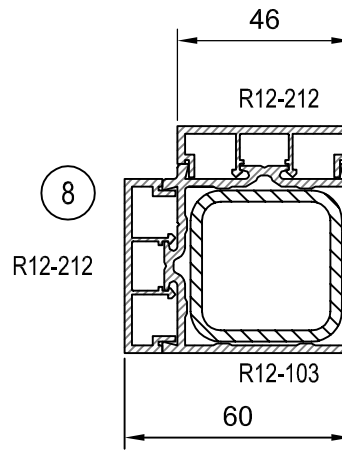
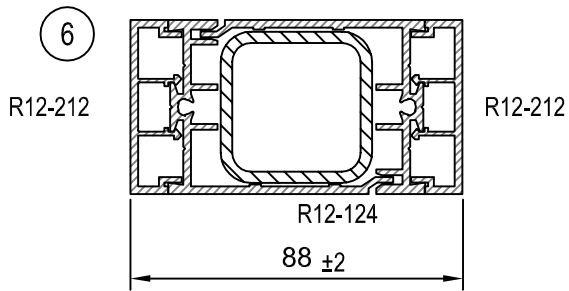
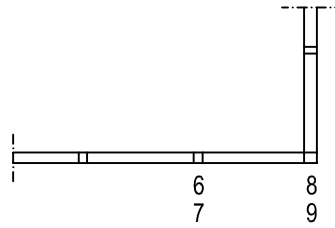
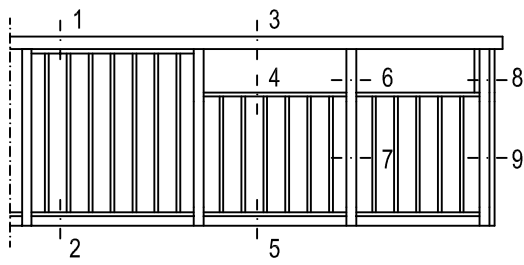

01.07.2013

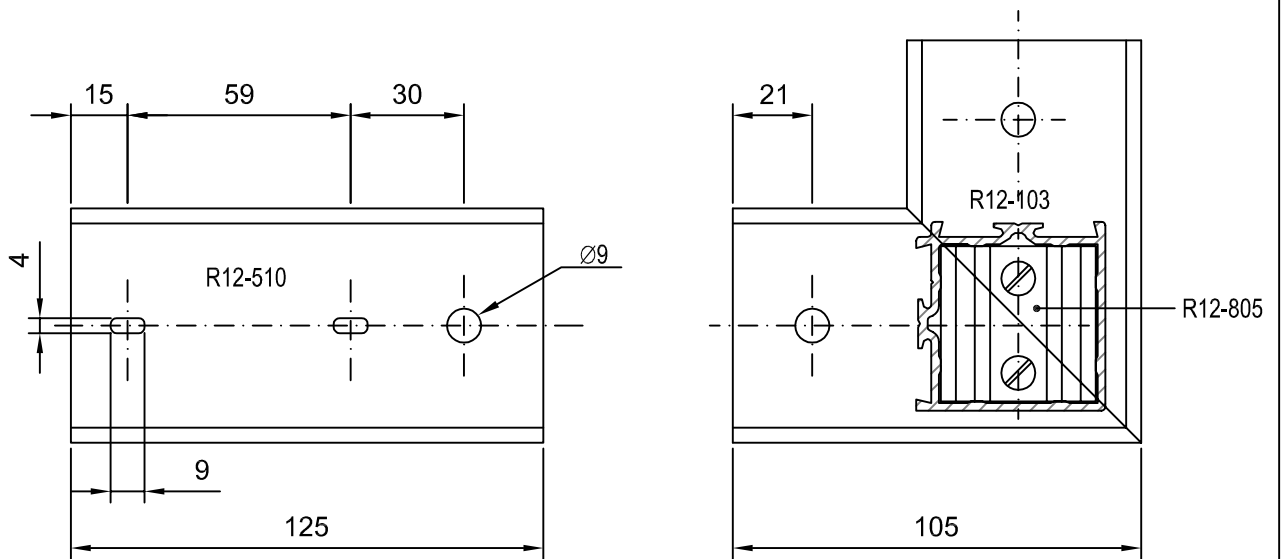
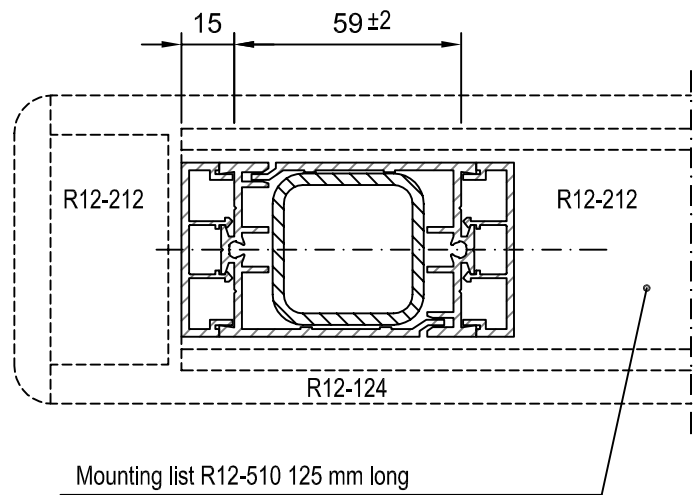
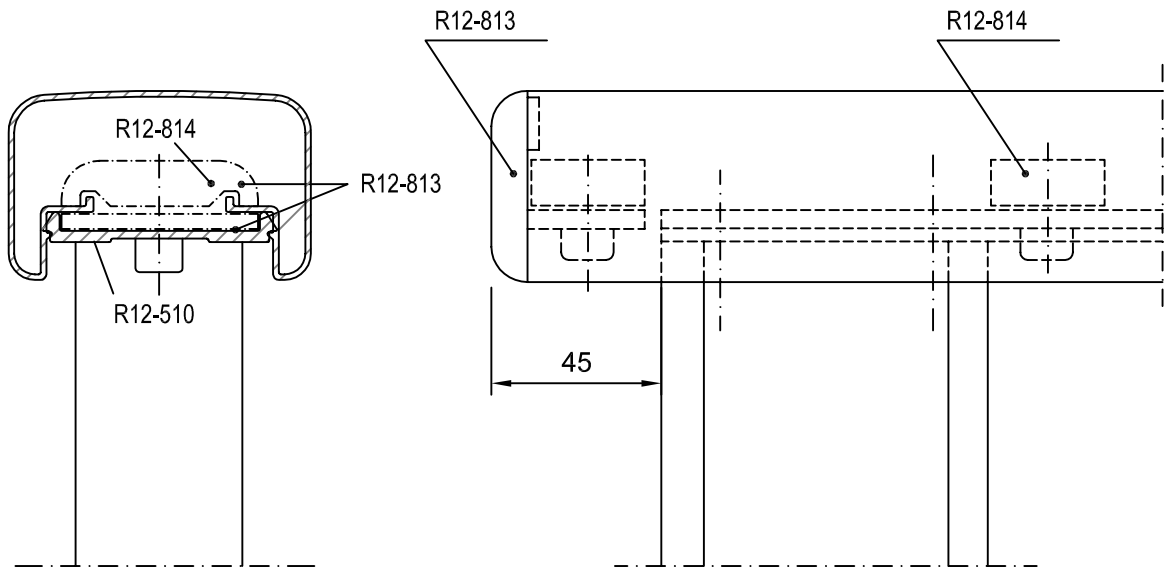

01.07.2013

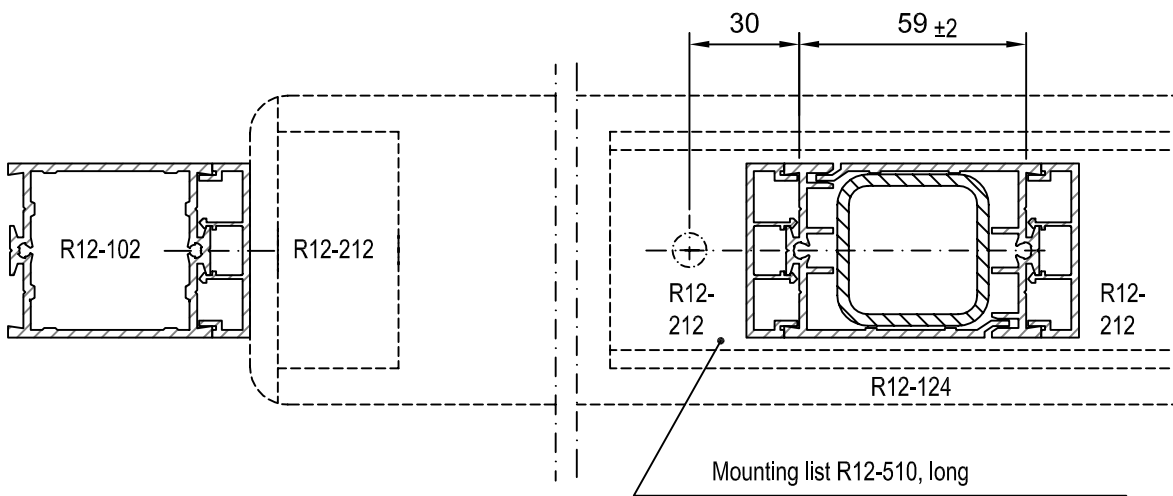
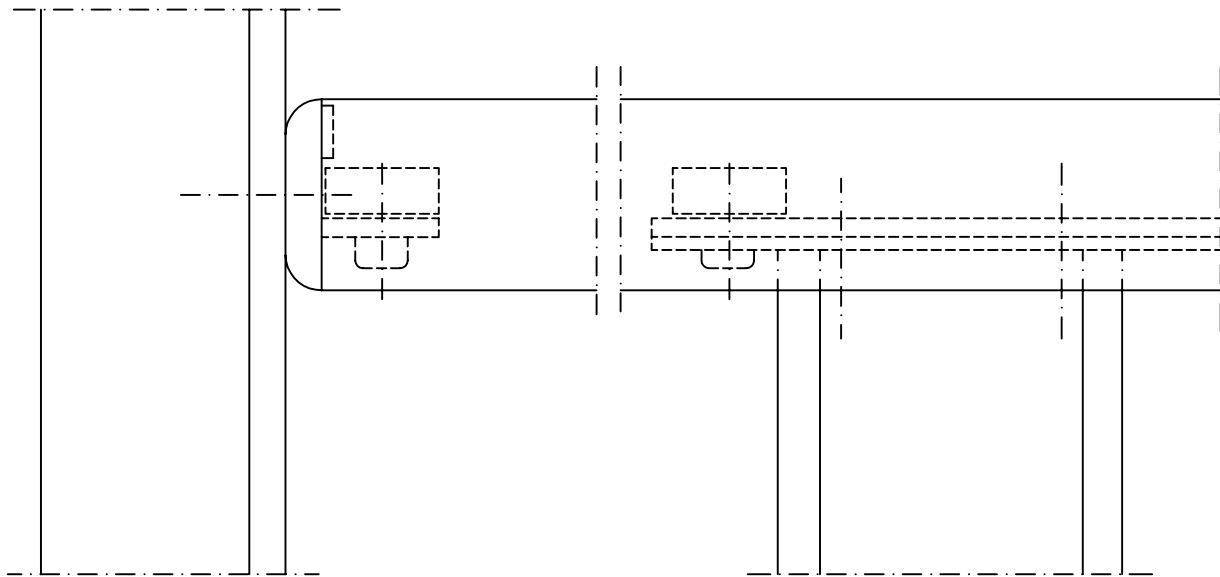

Post fastener

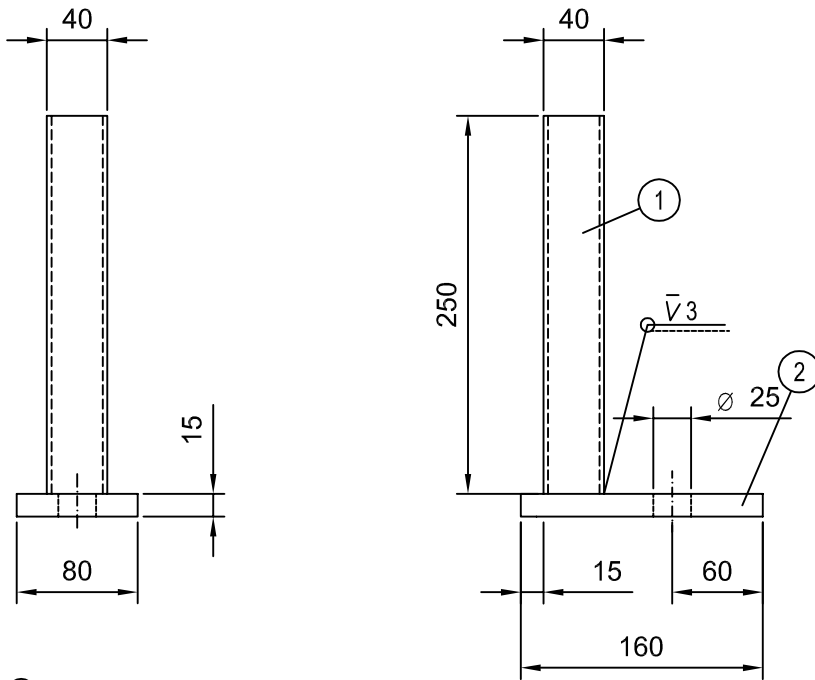

- ① Pipe 40x40x3 L=250
- ② Plate 80x160x15

Sinkitys ZnK 500 SFS 2765
stock package: pallet

Corner post fastener

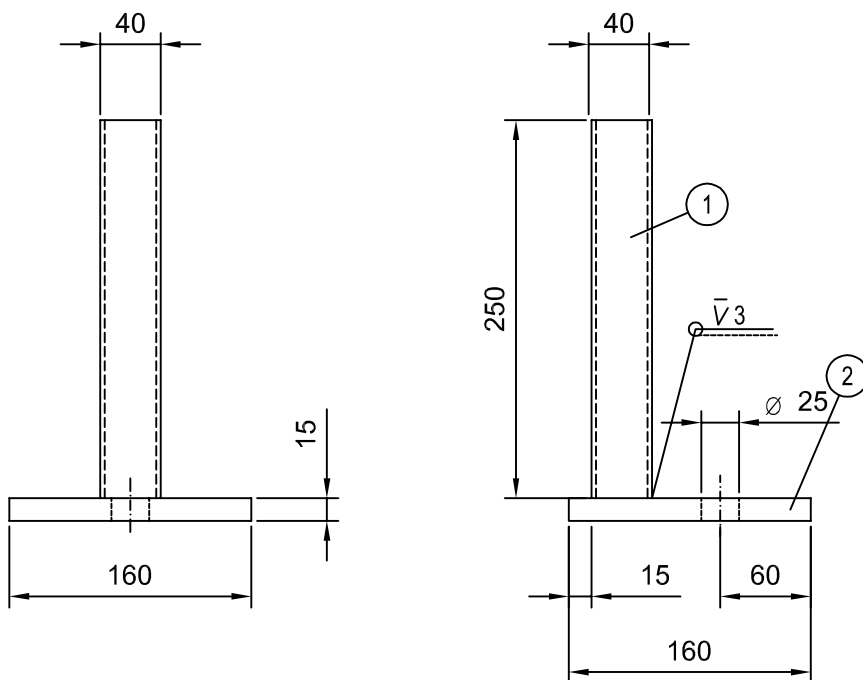

- ① Pipe 40x40x3 L=250
- ② Plate 80x160x15

Galvanization ZnK 500 SFS 2765
stock package: pallet

01.07.2013

1 Fastener to the concrete plane

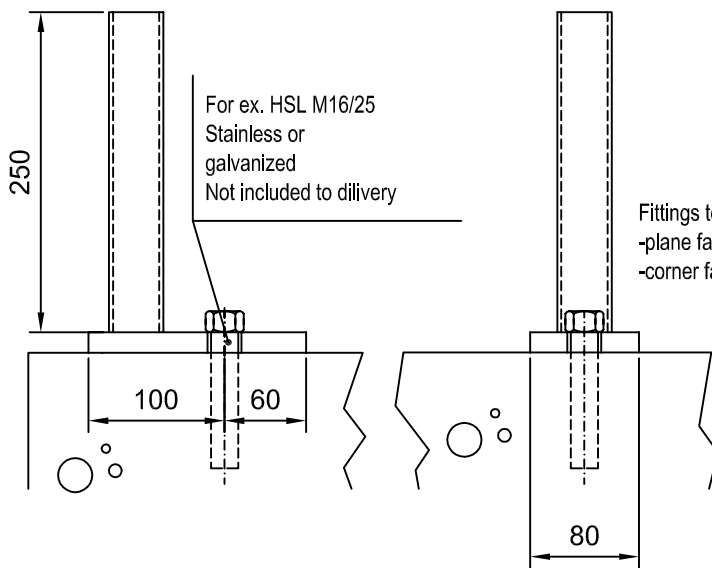

2 Connecting piece fixing plane, casted onto the concrete plane

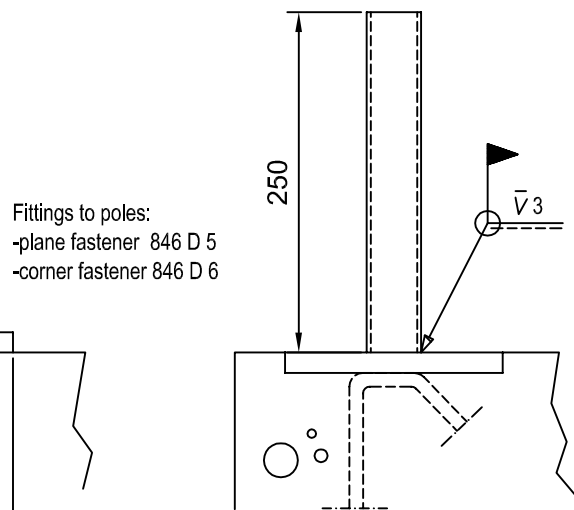

3 Connecting piece fixing plate, recessed to concrete; after-chilled

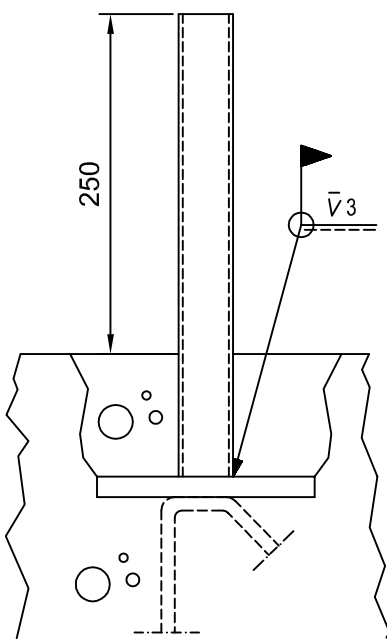

4 Side fixing to the concrete plane

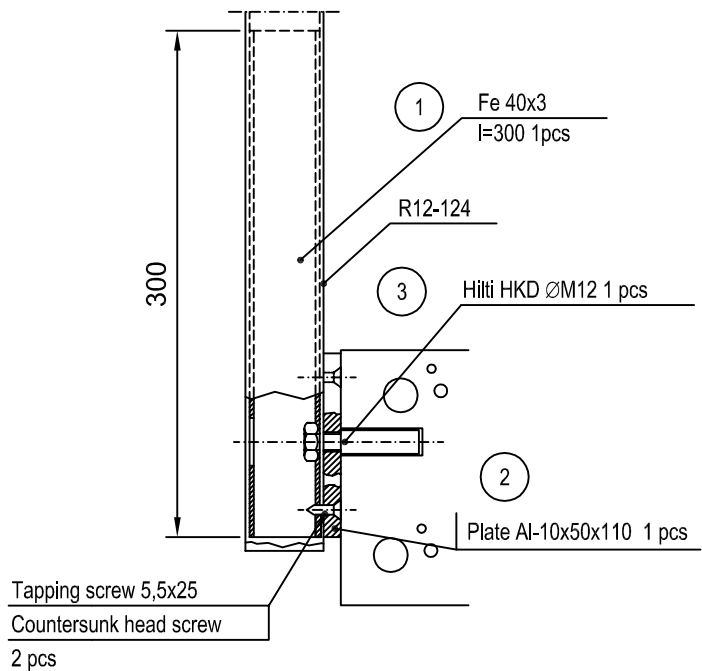

Weldings

Welding is made under the shelter from rain, snow and wind. Grooves must be dry, and clean from rust, paint, oil or other impurities. Quality grade HLO.

Note!

We are not responsible for the welding and surface treatment work which we do not control.

Surface treatment

The surfaces which are handled are cleaned from dirt, oil and grease. Welding marks are refined and rust is cleaned away. Surface preparation must be made immediately or at least on the same day than cleaning. When starting preparation make sure that surfaces are dry after cemical treatments. Final surface treatment is made with suitable materials and methods for circumstances.

Allowed moment for fasteners and bonds is 800 Nm. All parts are hot galvanized ZnK 500 SFS 2765.